

Access Strategy Option A

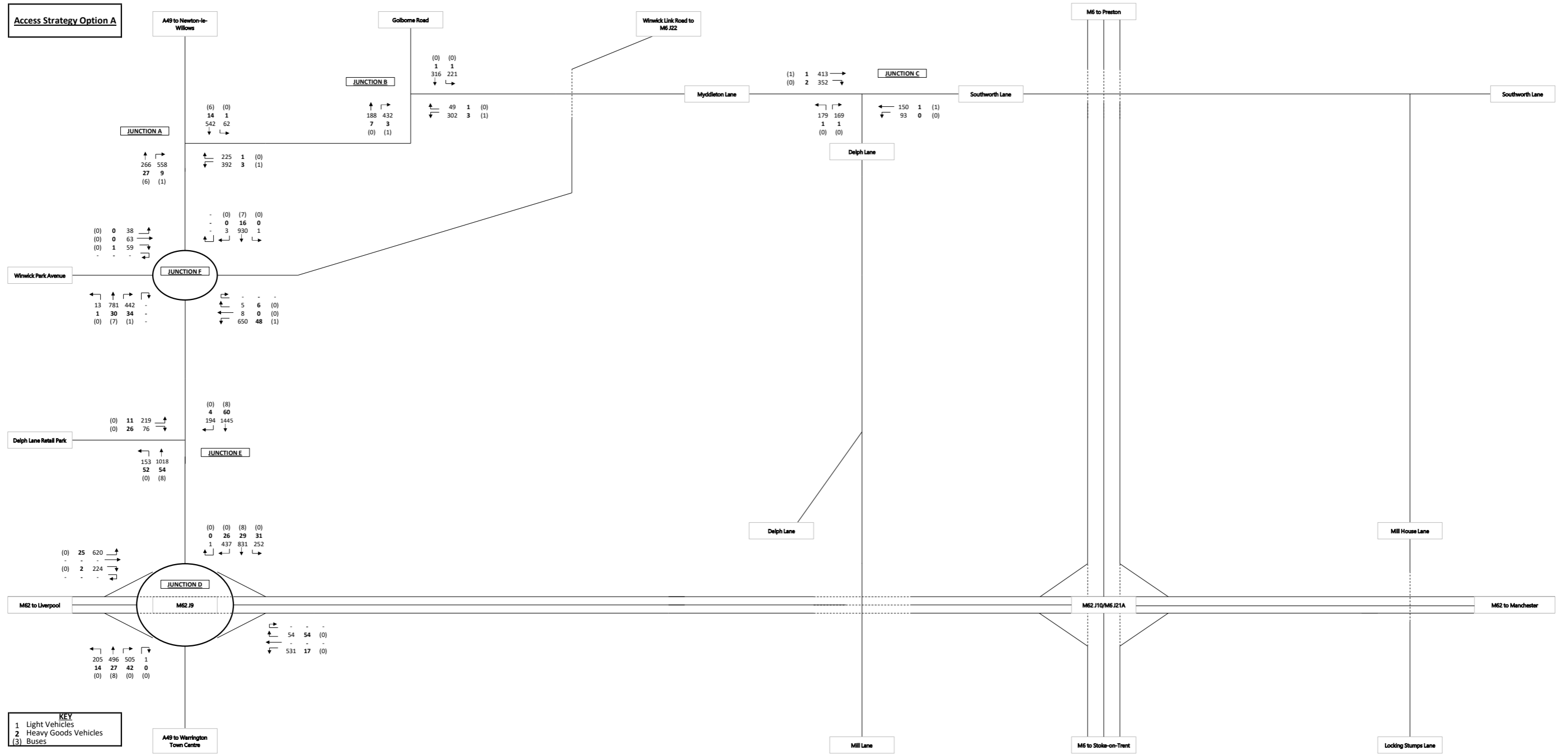

KEY
 1 Light Vehicles
 2 Heavy Goods Vehicles
 3 Buses

PROPOSED DEVELOPMENT: Peel Hall, Warrington
 AM Demand

2018 - Do Minimum (N of M62)

Access Strategy Option A

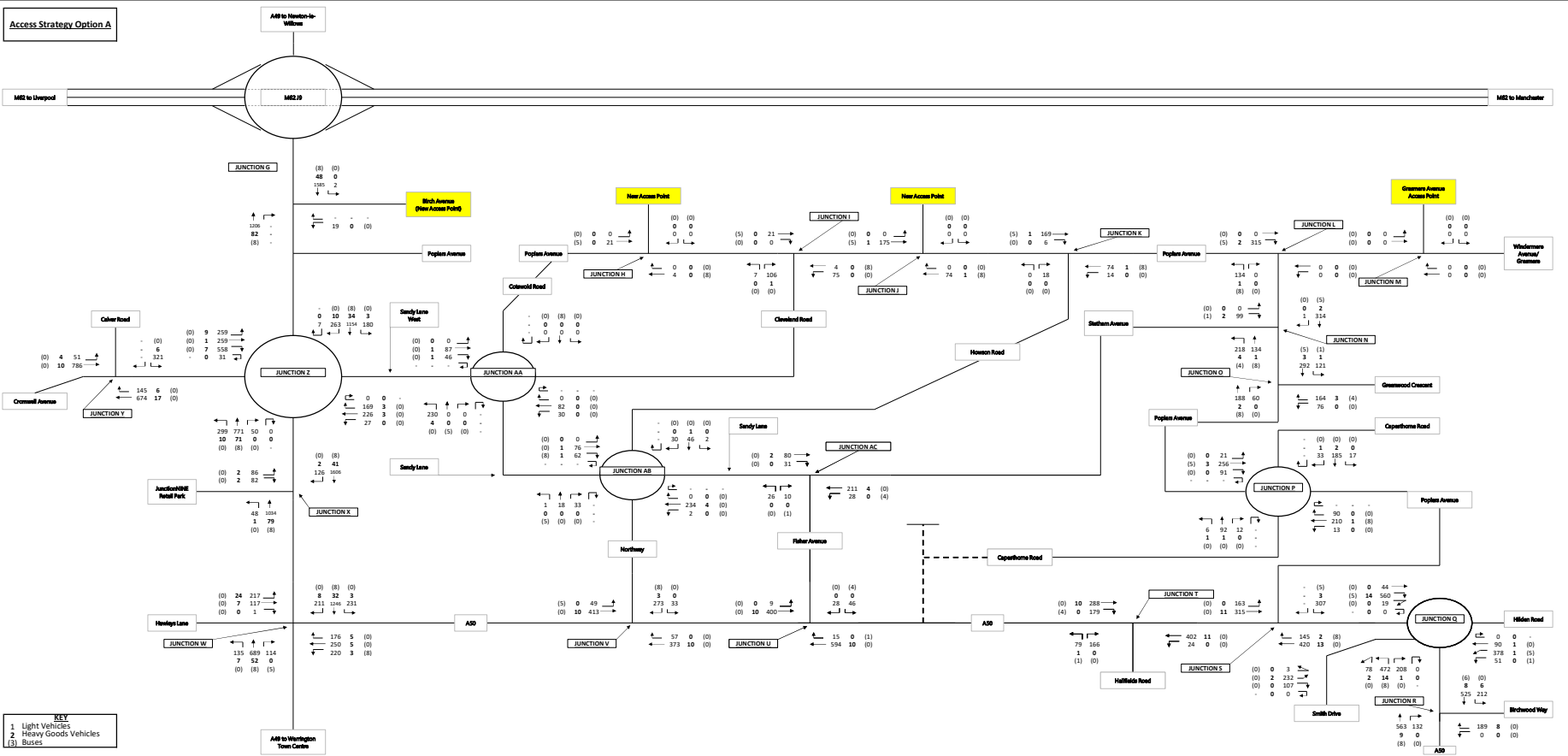

- KEY**
 1 Light Vehicles
 2 Heavy Goods Vehicles
 3 Buses

PROPOSED DEVELOPMENT: Peel Hall, Warrington
 AM Demand

2018 - Do Minimum (SW of M62)

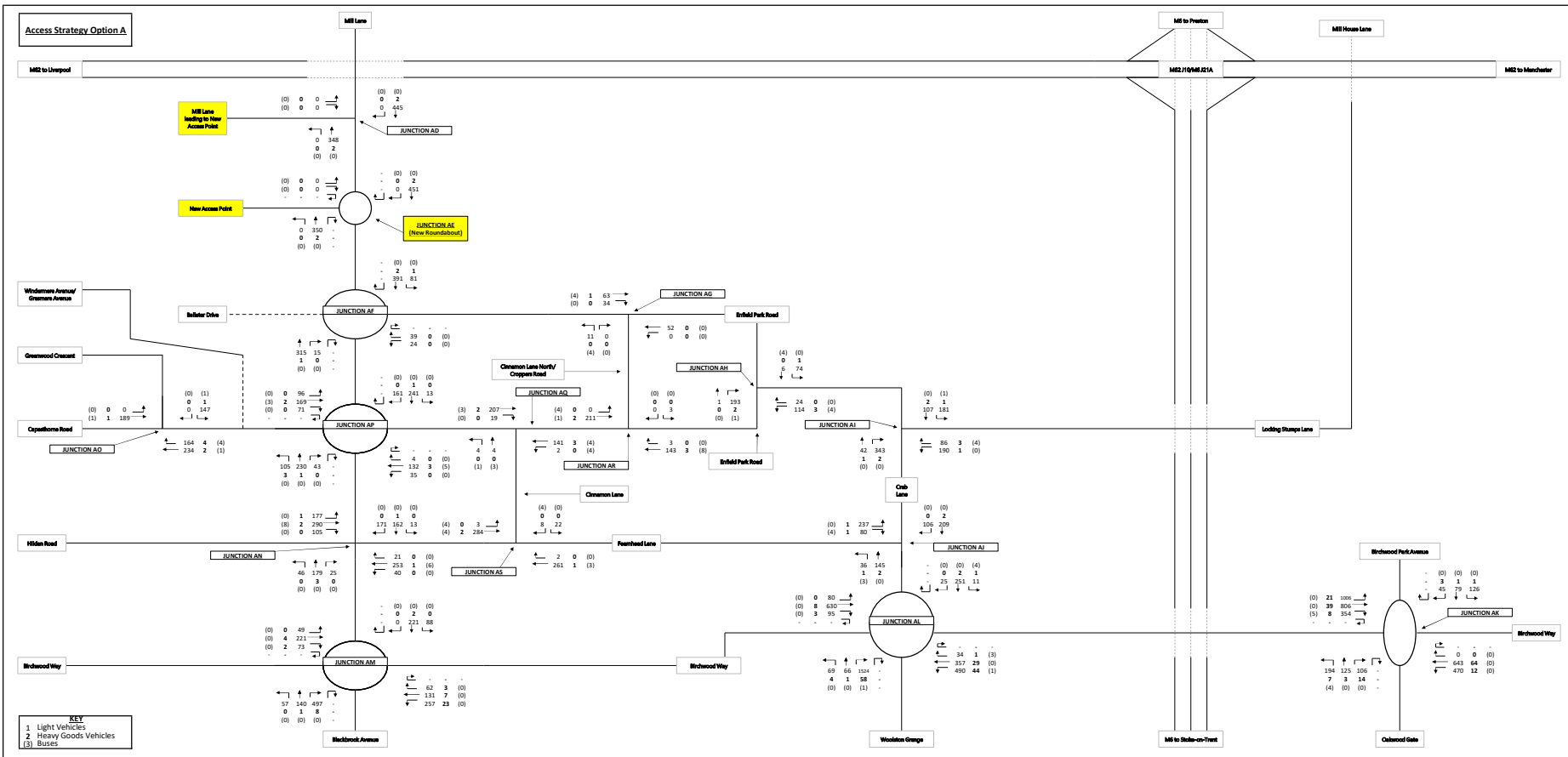

2018 - Do Minimum (SE of M62)

Access Strategy Option A

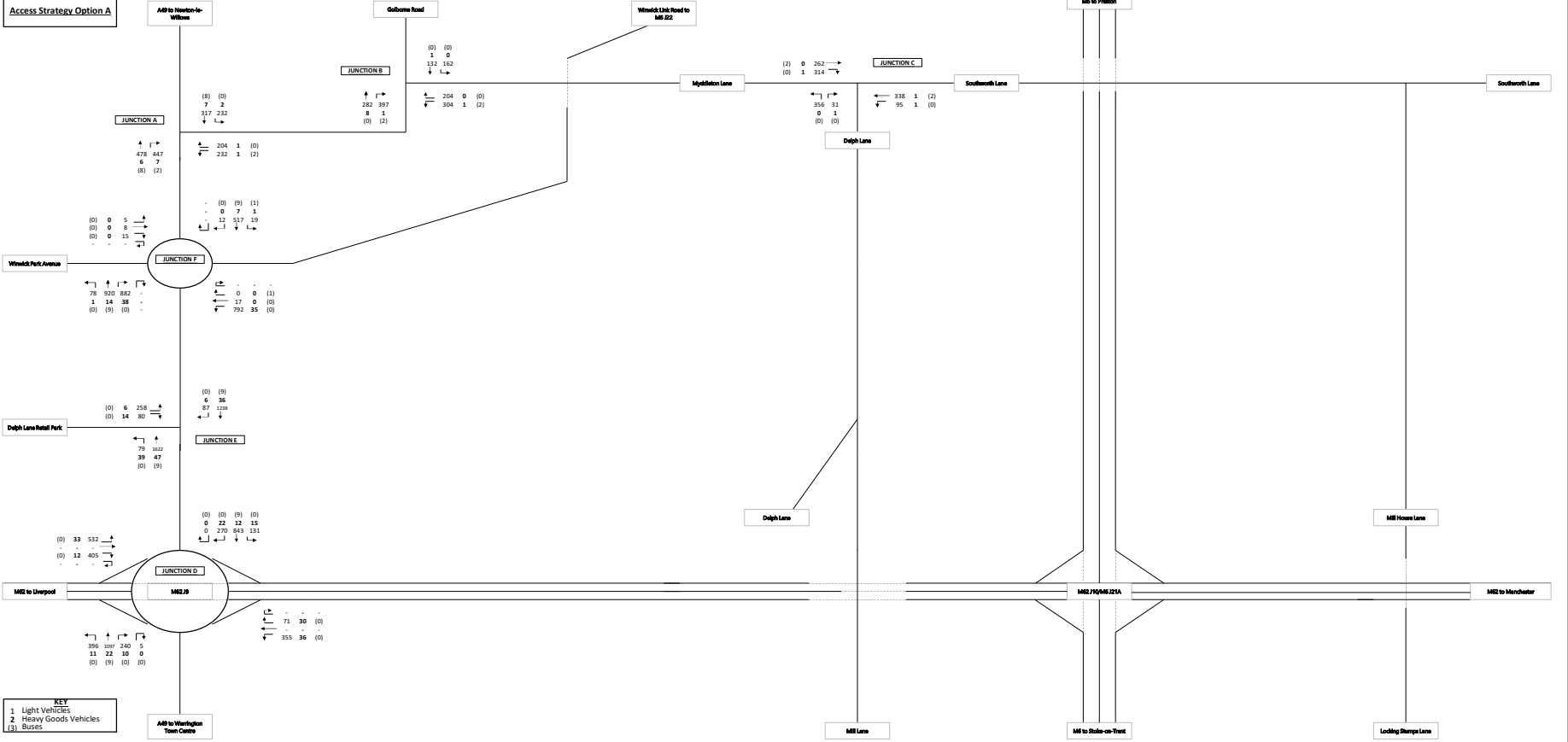

- KEY**
- 1 Light Vehicles
 - 2 Heavy Goods Vehicles
 - (3) Buses

PROPOSED DEVELOPMENT: Peel Hall, Warrington
PM Demand

2018 - Do Minimum (N of M62)

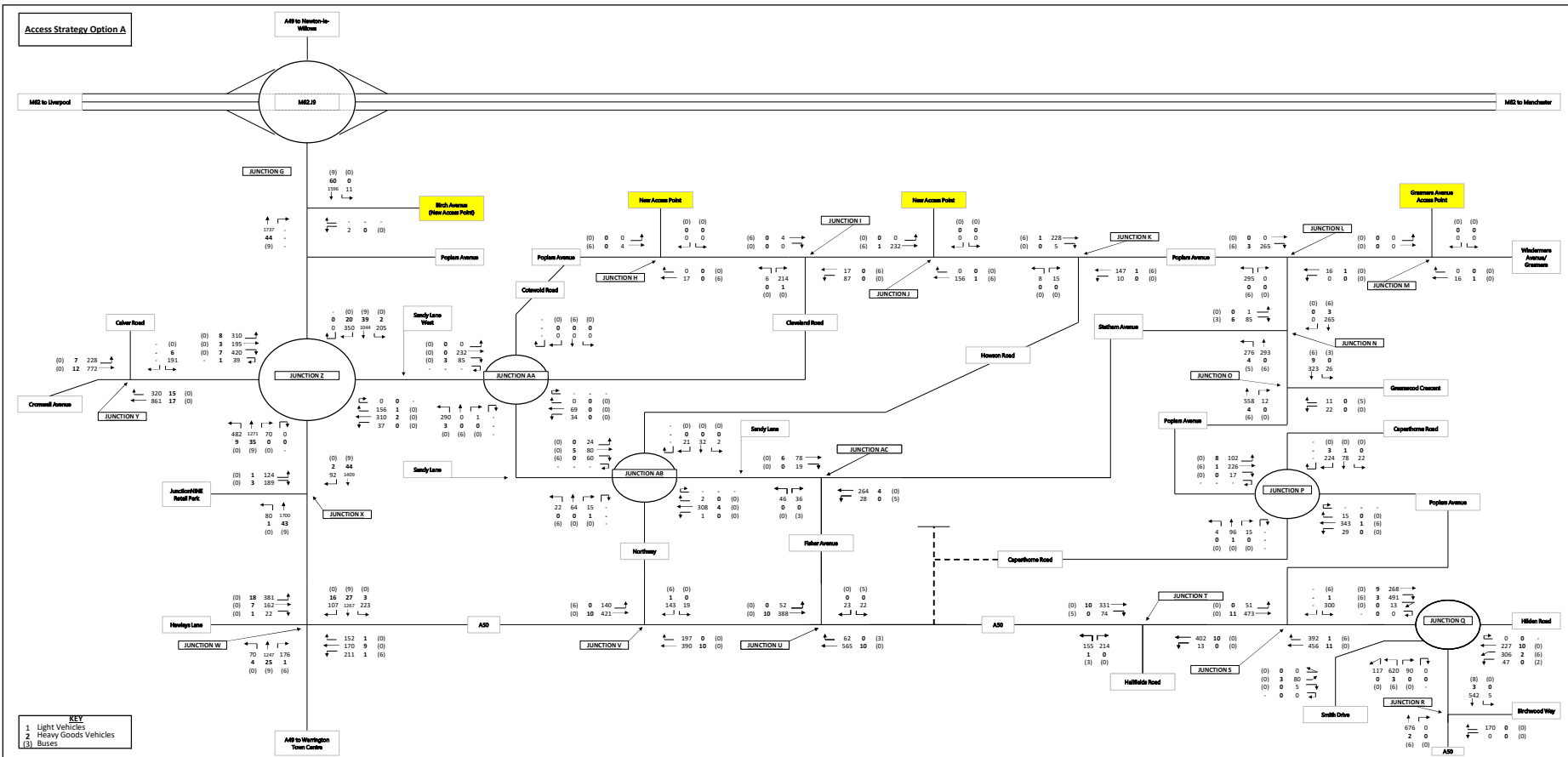

PROPOSED DEVELOPMENT: Peel Hall, Warrington
PM Demand

2018 - Do Minimum (SW of M62)

Access Strategy Option A

M62 to Liverpool

M6 to Preston

M61 House Lane

M62 J10/M21A

M62 to Manchester

M61 Lane leading to New Access Point

New Access Point

Wholesome Avenue/
Grennam Avenue

Greenwood Crescent

Copthorne Road

Hidden Road

Birchwood Way

- KEY**
 1 Light Vehicles
 2 Heavy Goods Vehicles
 (3) Buses

PROPOSED DEVELOPMENT: Peel Hall, Warrington
 PM Demand

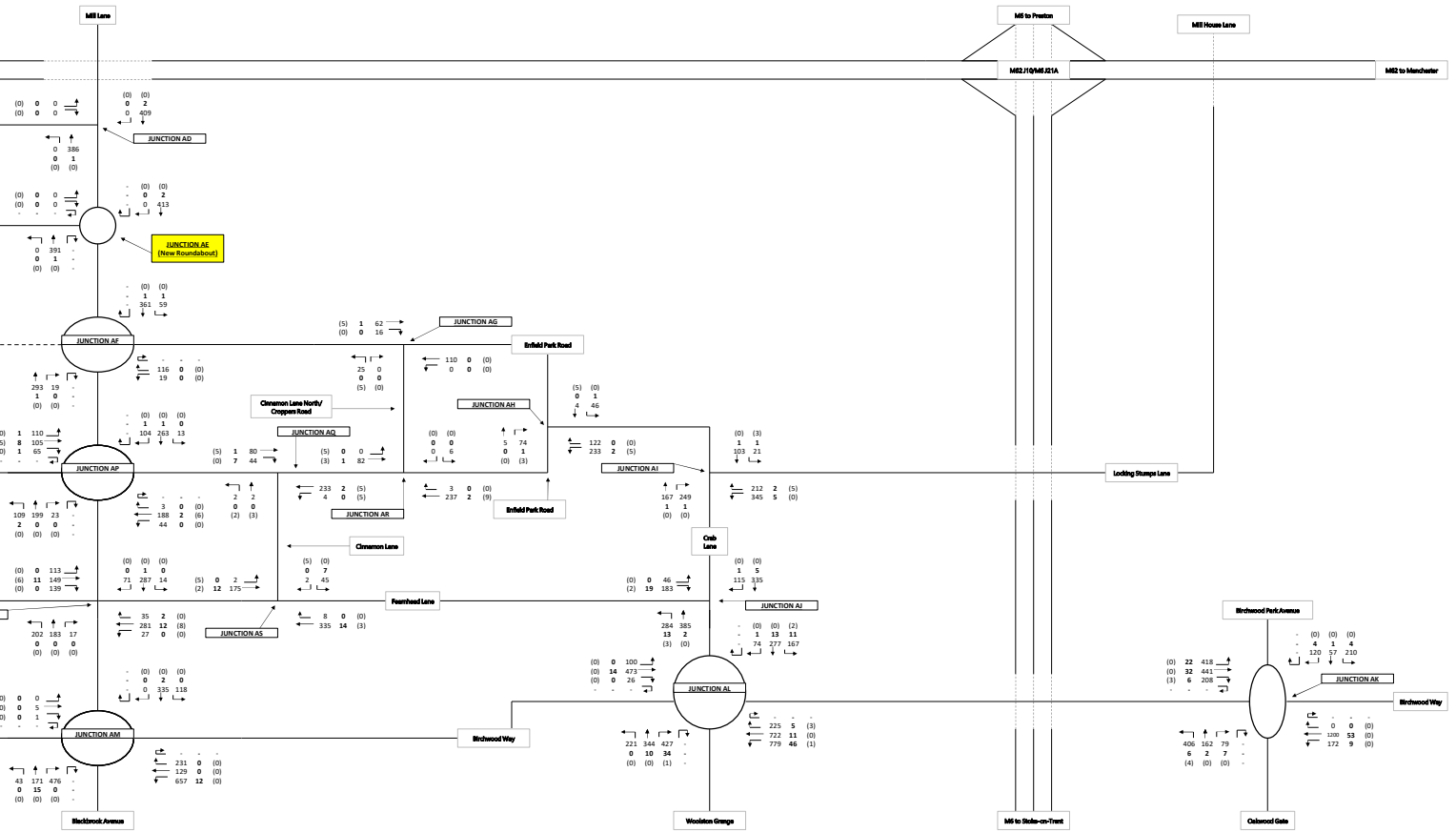

2018 - Do Minimum (SE of M62)

Access Strategy Option A

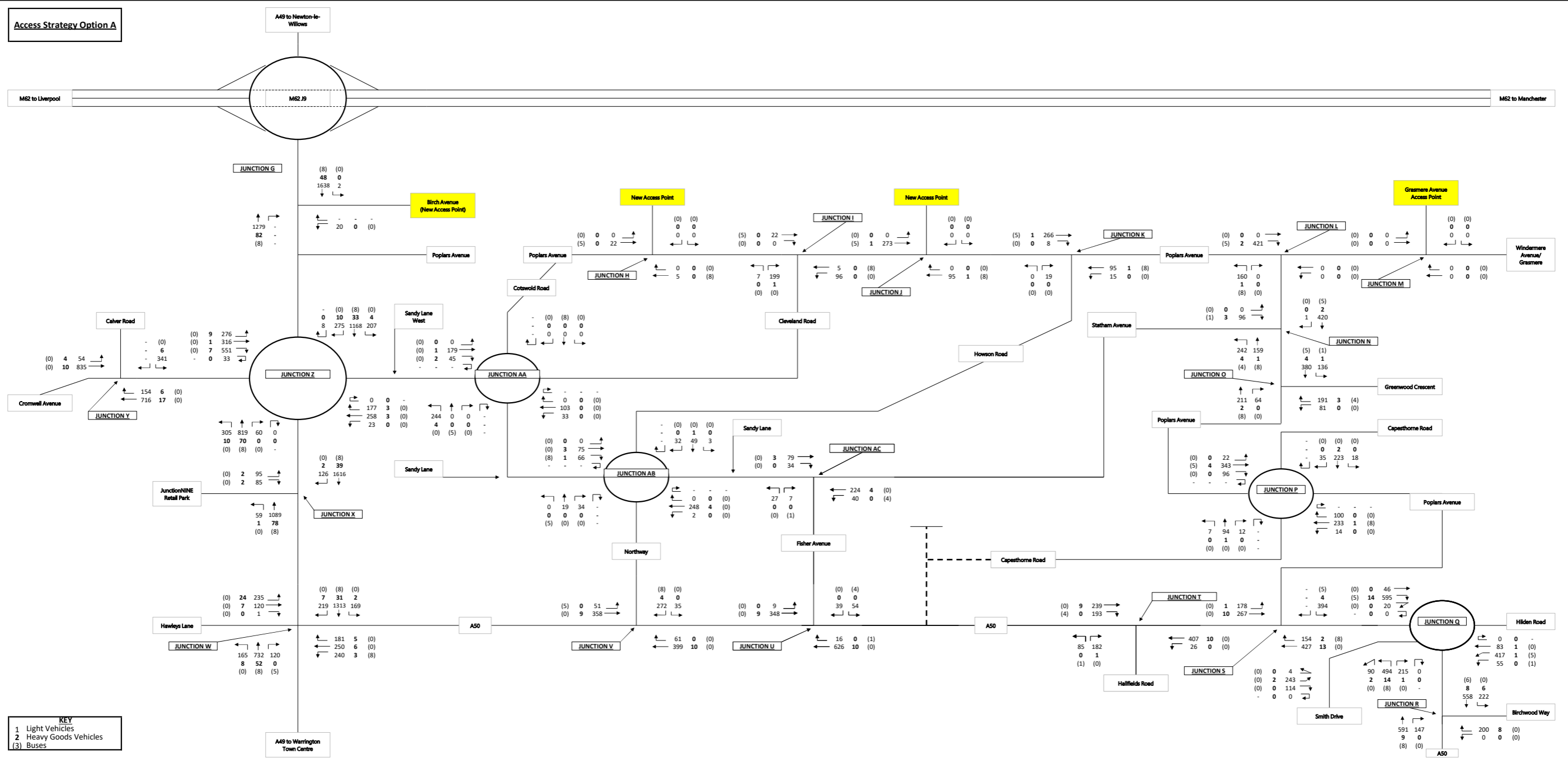

KEY
 1 Light Vehicles
 2 Heavy Goods Vehicles
 3 Buses

PROPOSED DEVELOPMENT: Peel Hall, Warrington
 AM Demand

2022 - Do Minimum (SW of M62)

HighgateTransportation

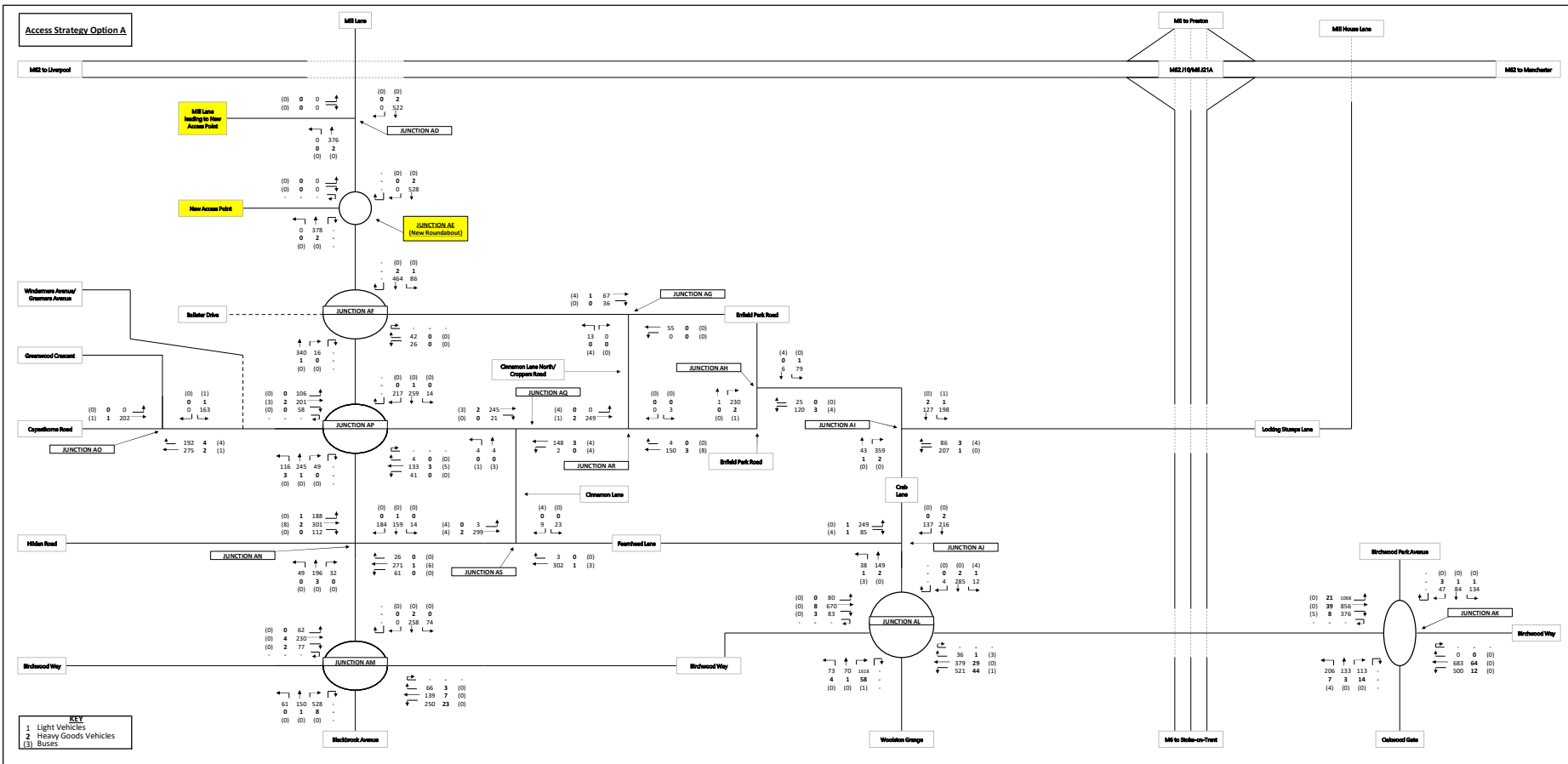

2022 - Do Minimum (SE of M62)

Access Strategy Option A

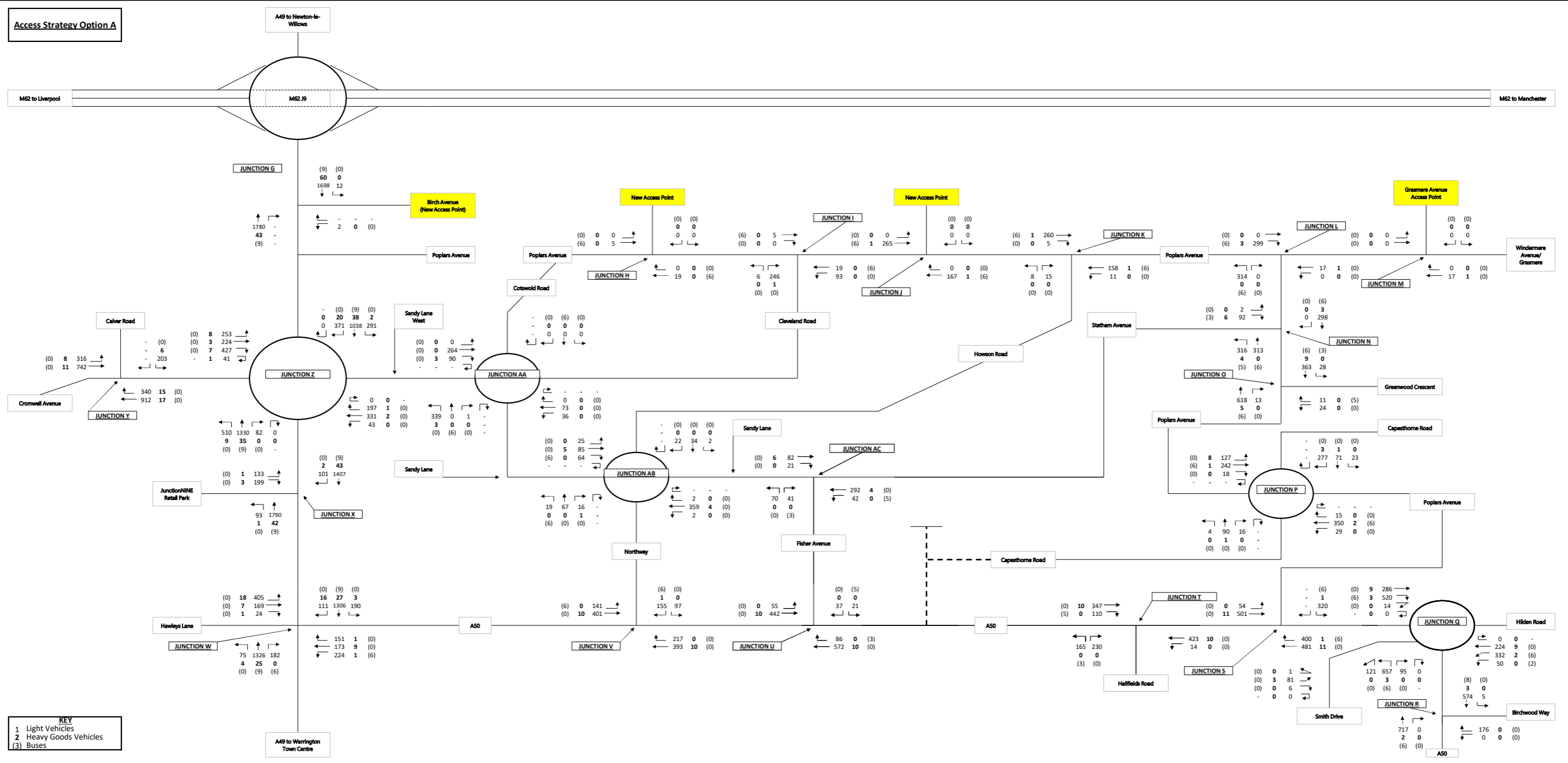

KEY

1	Light Vehicles
2	Heavy Goods Vehicles
3	Buses

PROPOSED DEVELOPMENT: Peel Hall, Warrington
PM Demand

2022 - Do Minimum (SW of M62)

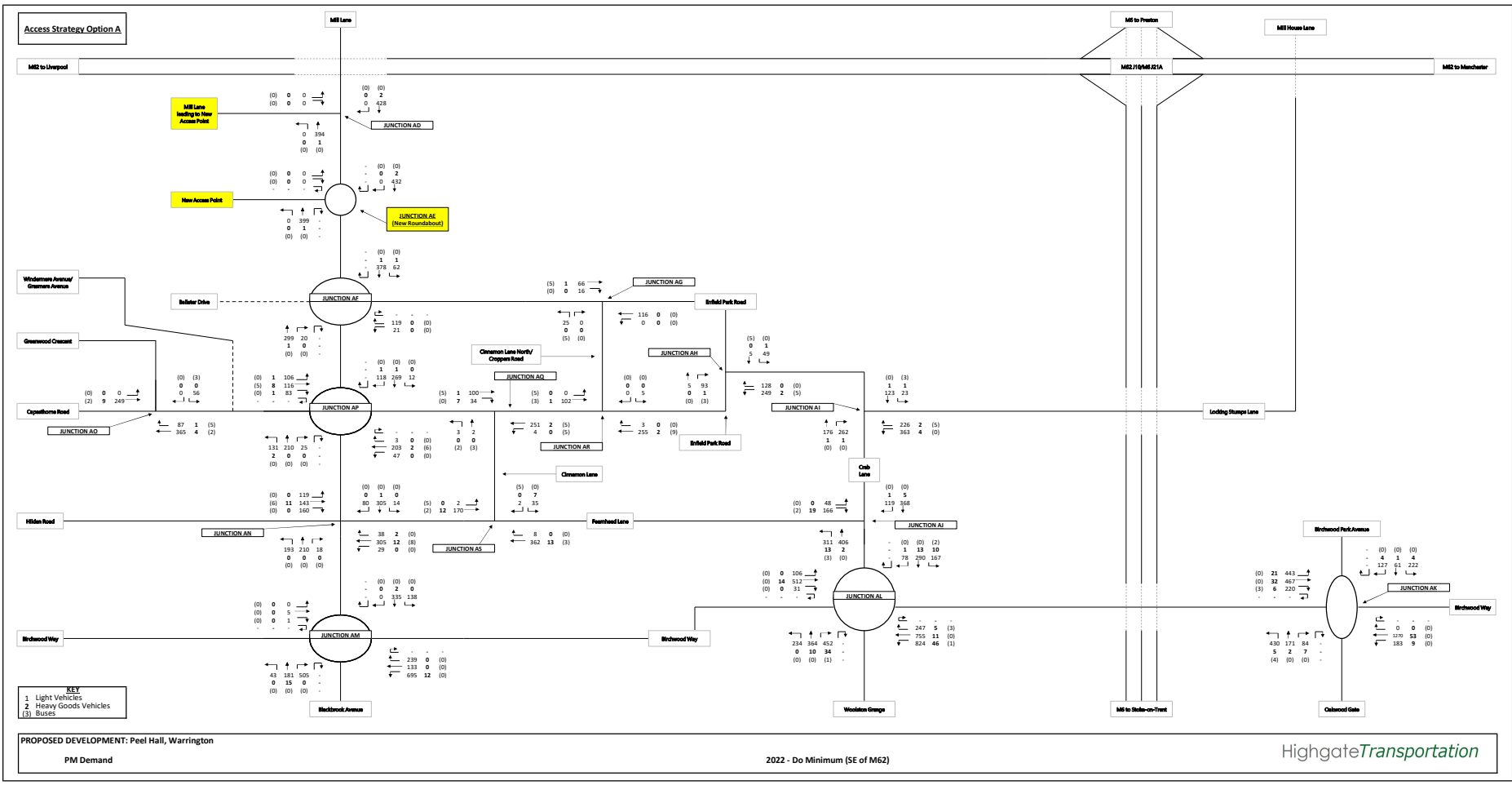

Access Strategy Option A

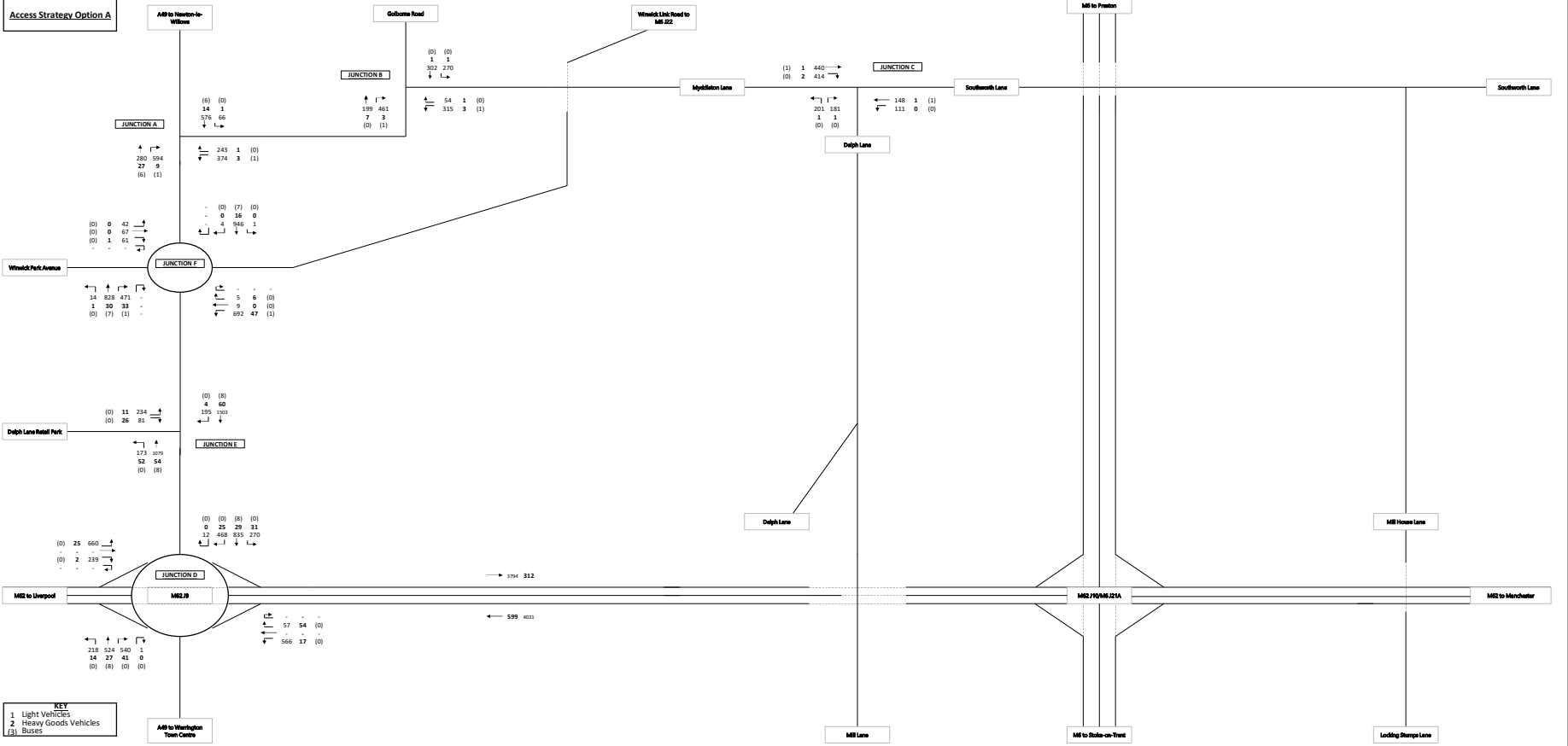

KEY
 1 Light Vehicles
 2 Heavy Goods Vehicles
 (3) Buses

PROPOSED DEVELOPMENT: Peel Hall, Warrington
 AM Demand

2022 - Do Something (N of M62)

Access Strategy Option A

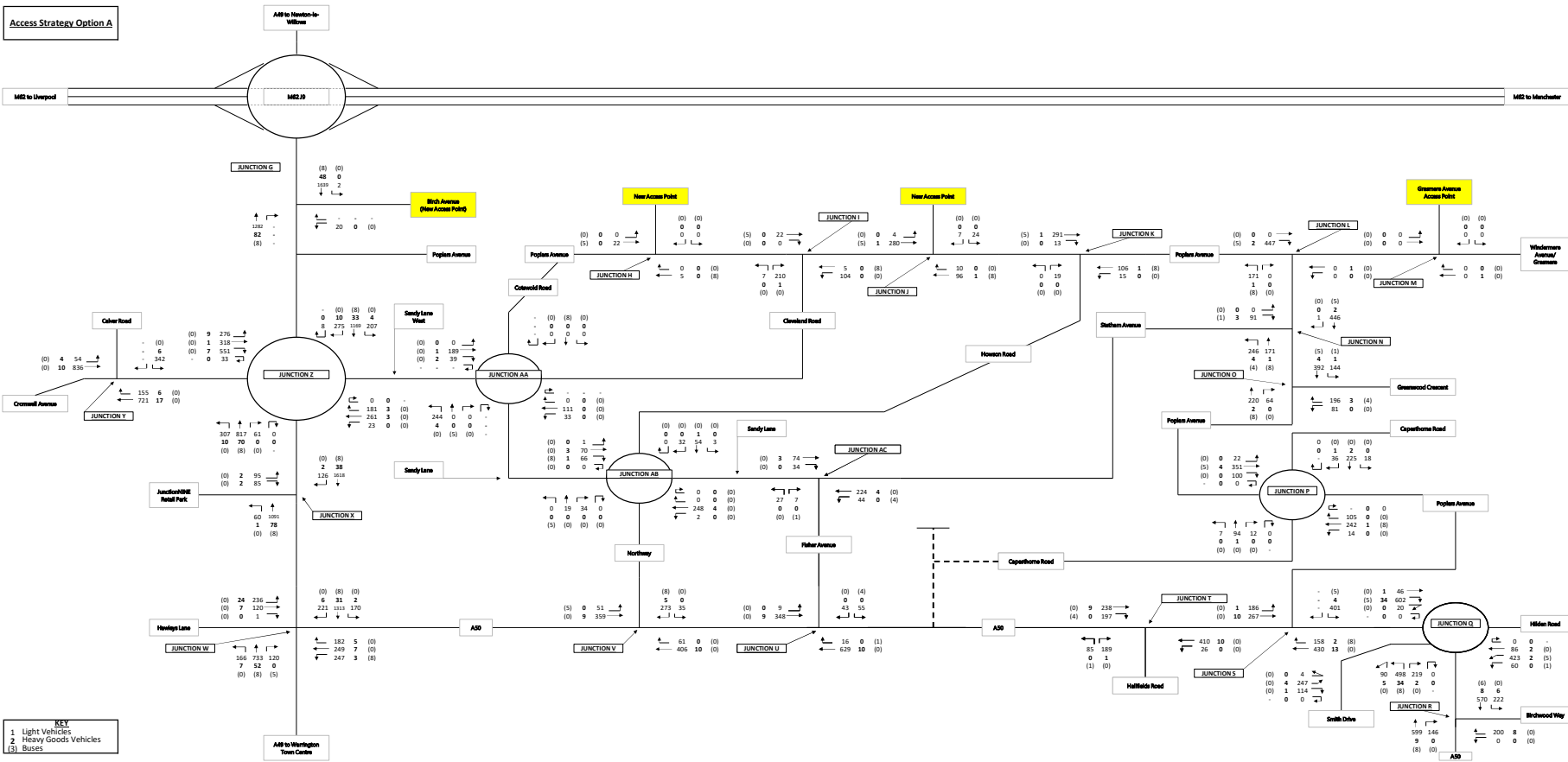

PROPOSED DEVELOPMENT: Peel Hall, Warrington
AM Demand

2022 - Do Something (SW of M62)

Access Strategy Option A

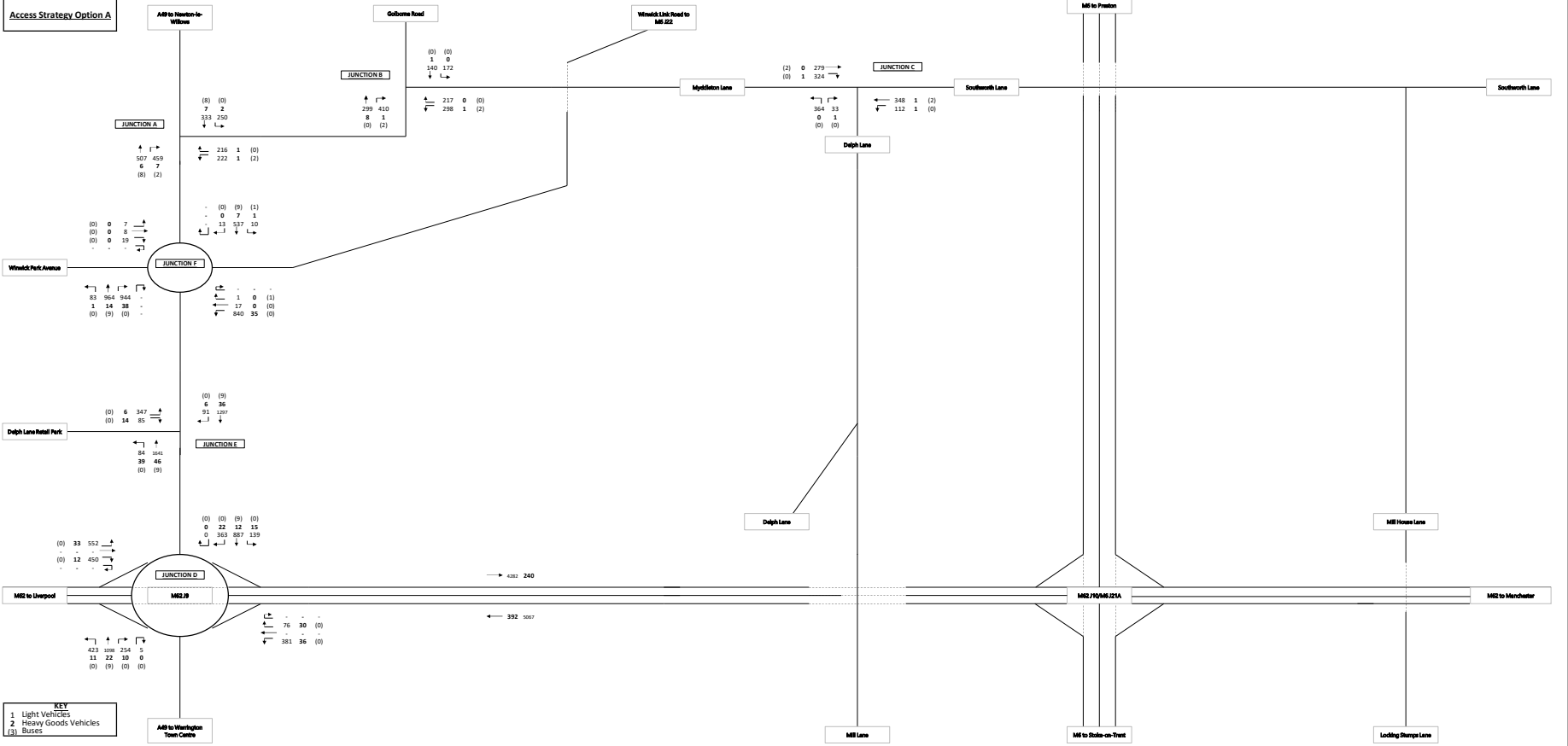

- KEY**
- 1 Light Vehicles
 - 2 Heavy Goods Vehicles
 - (3) Buses

PROPOSED DEVELOPMENT: Peel Hall, Warrington
PM Demand

2022 - Do Something (N of M62)

Access Strategy Option A

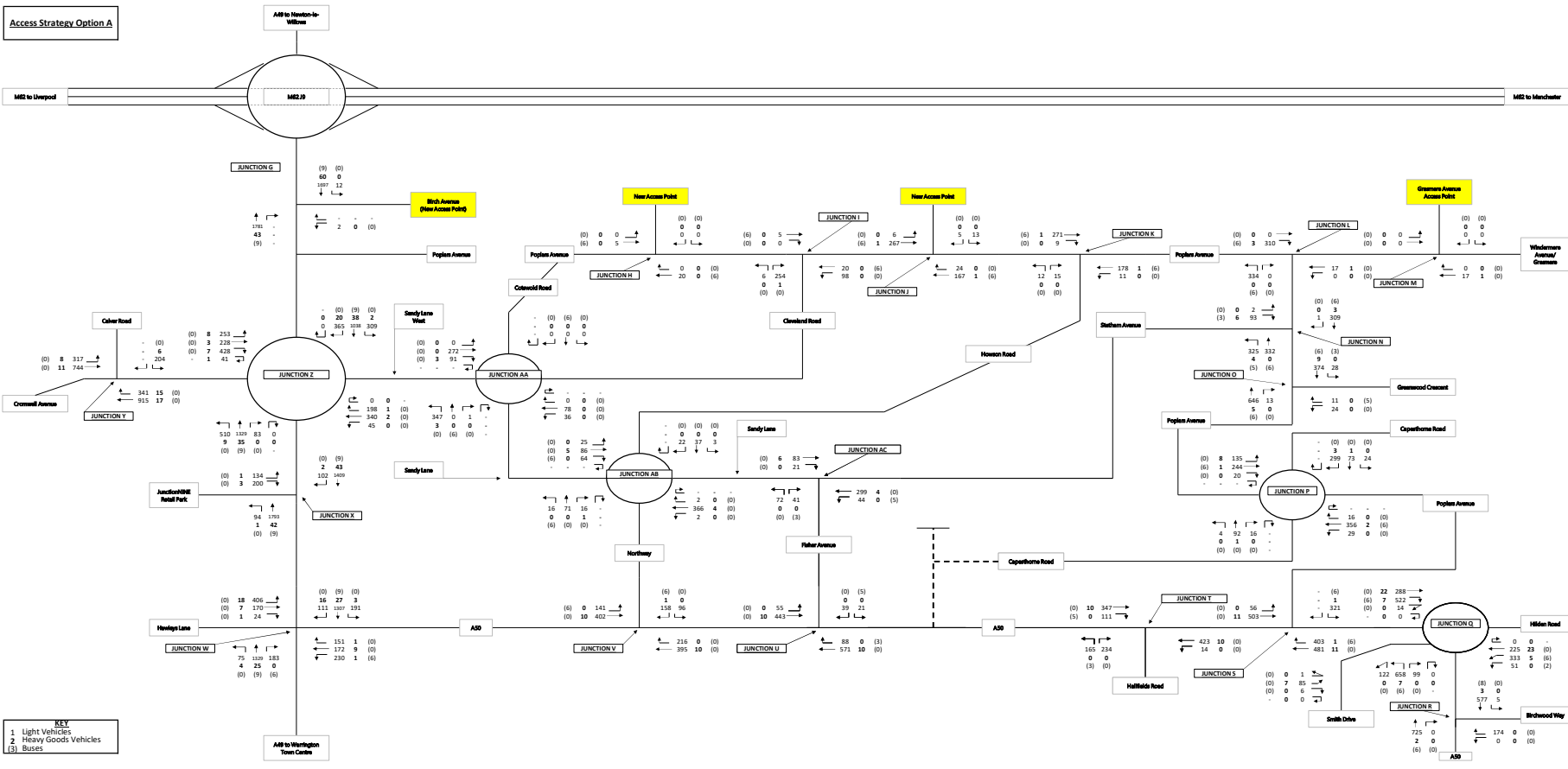

KEY
 1 Light Vehicles
 2 Heavy Goods Vehicles
 3 Buses

PROPOSED DEVELOPMENT: Peel Hall, Warrington
 PM Demand

2022 - Do Something (SW of M62)

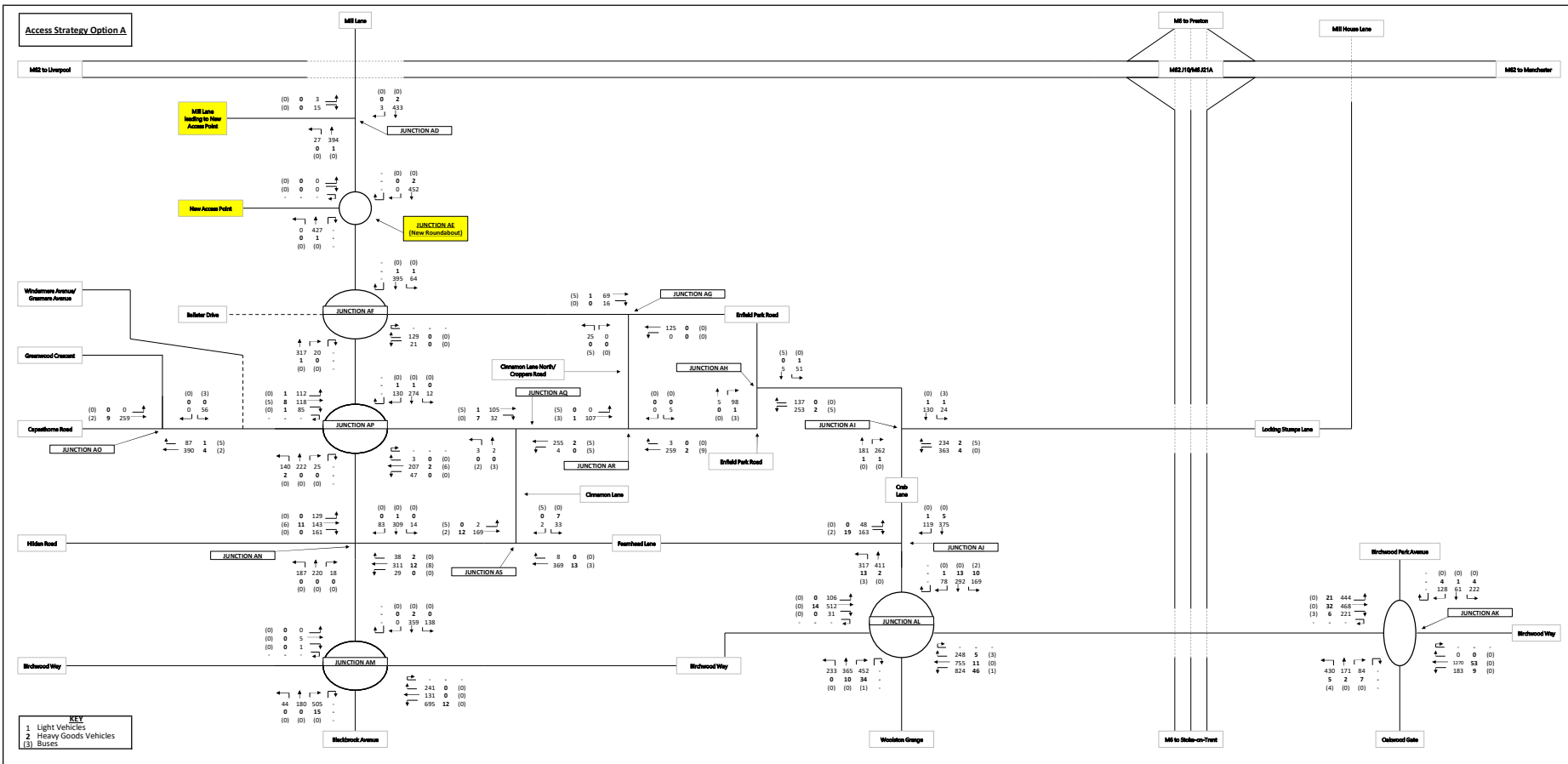

Access Strategy Option A

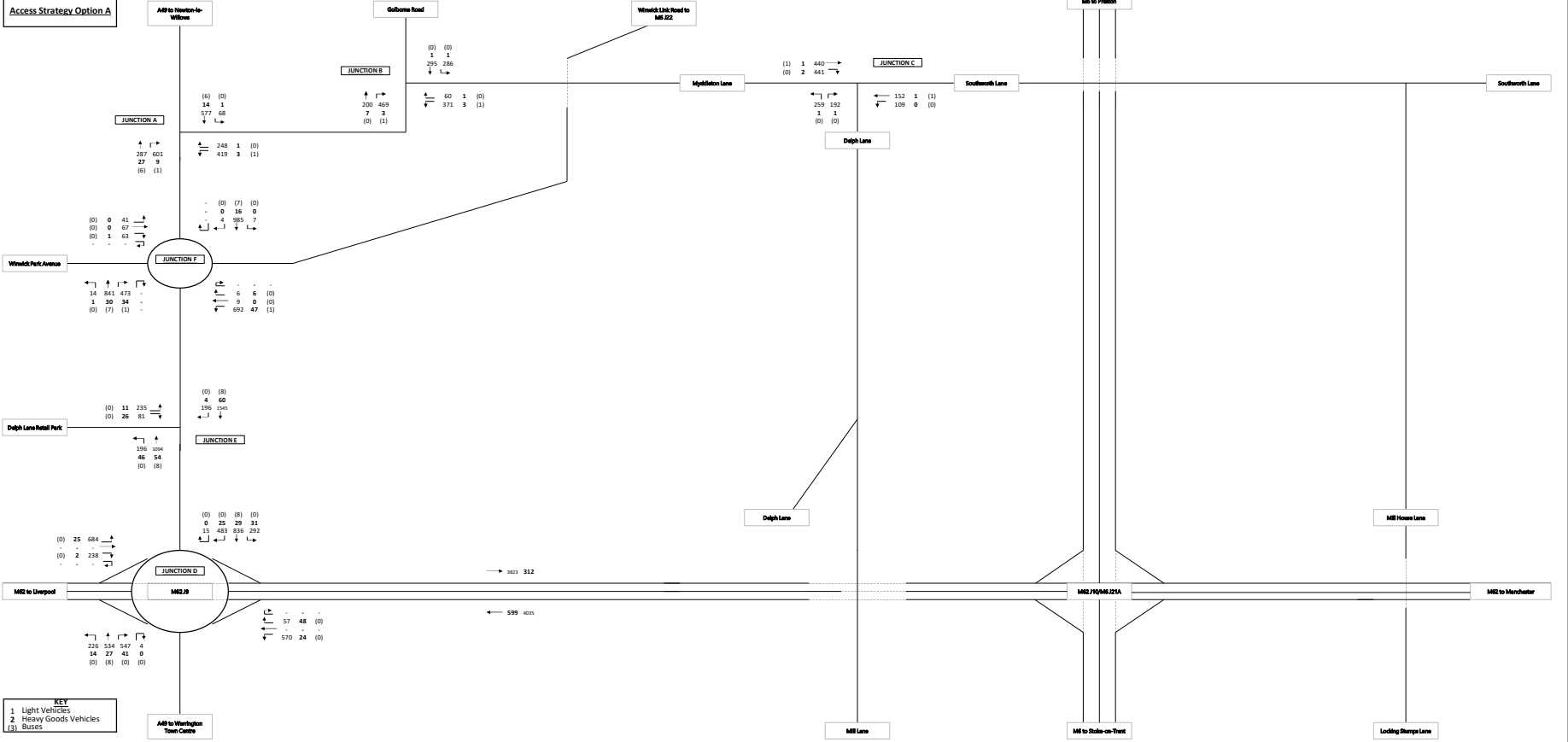

PROPOSED DEVELOPMENT: Peel Hall, Warrington
AM Demand

Access Strategy Option A

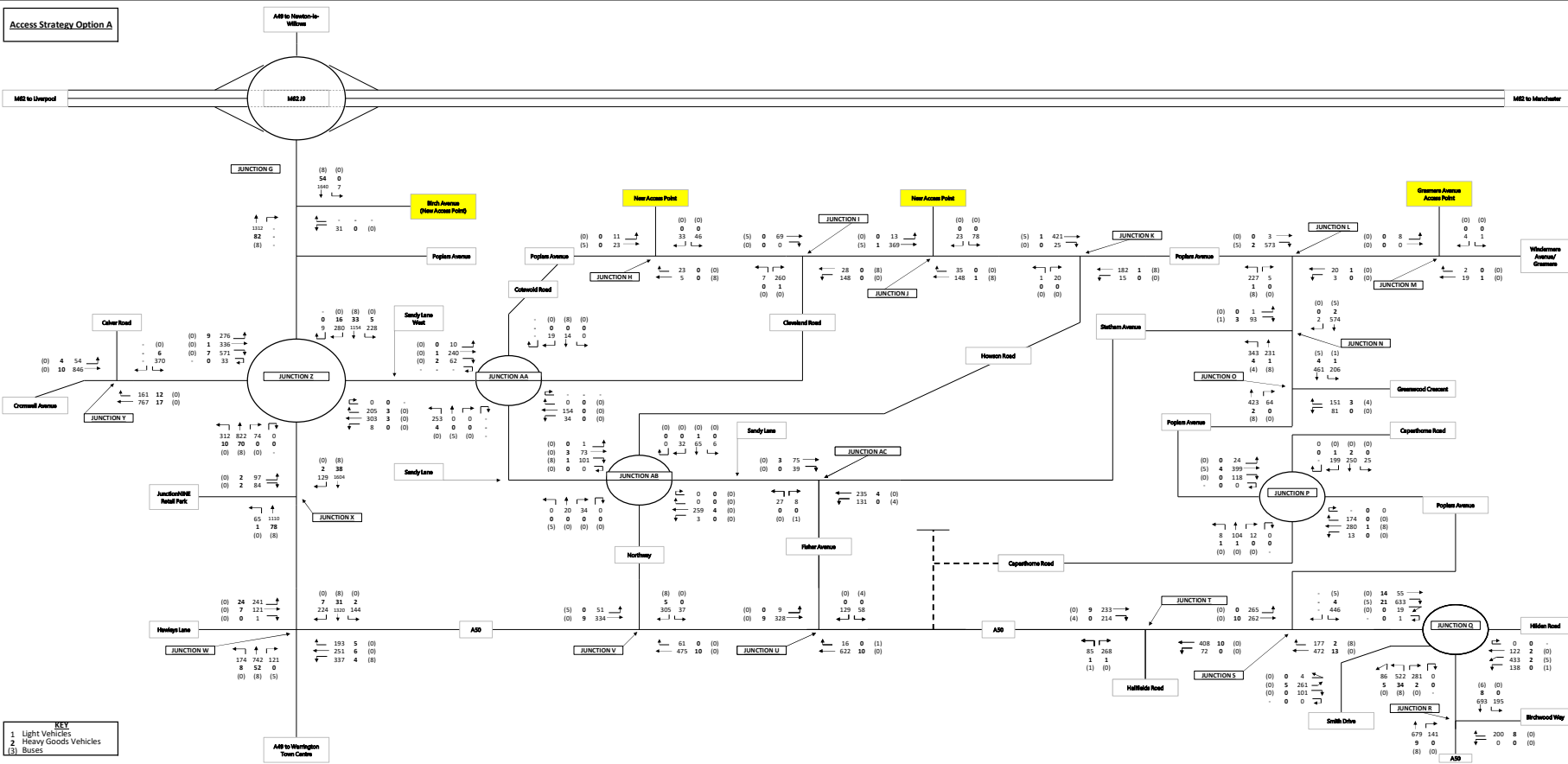

2022 - Do Something (FULL Development) (SW of M62)

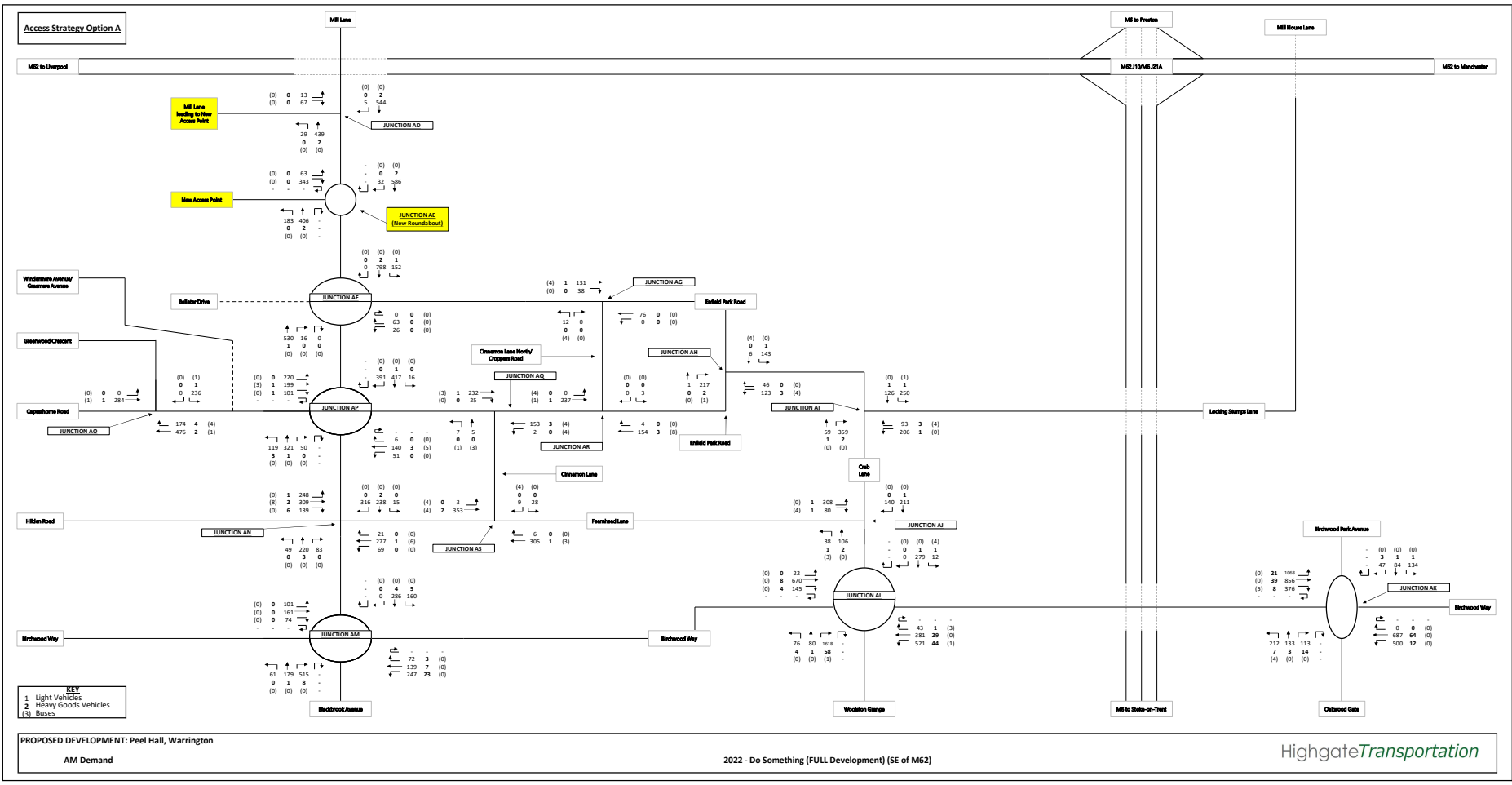

Access Strategy Option A

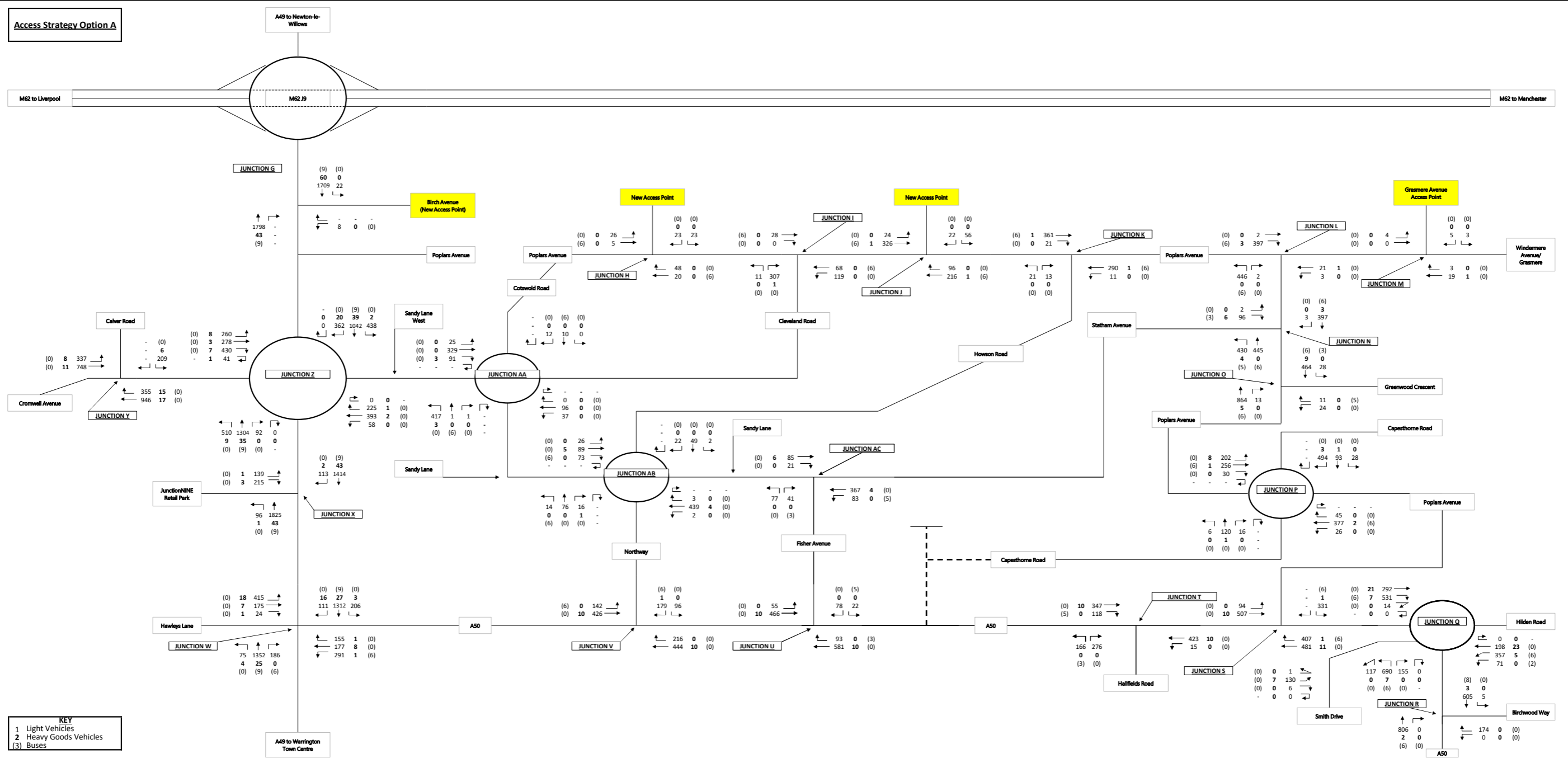

KEY
 1 Light Vehicles
 2 Heavy Goods Vehicles
 3 Buses

PROPOSED DEVELOPMENT: Peel Hall, Warrington
 PM Demand

2022 - Do Something (FULL Development) (SW of M62)

Access Strategy Option A

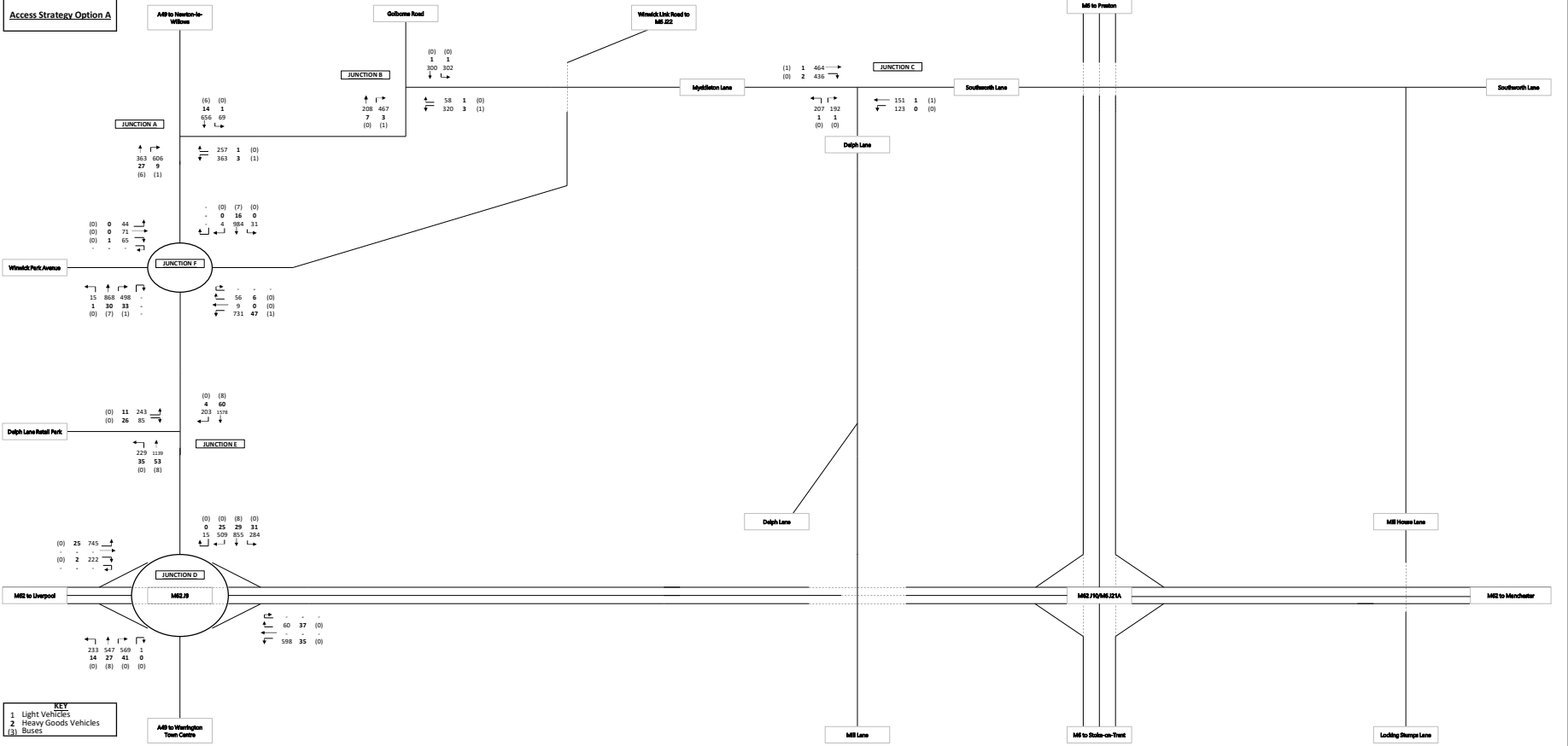

2027 - Do Minimum (N of M62)

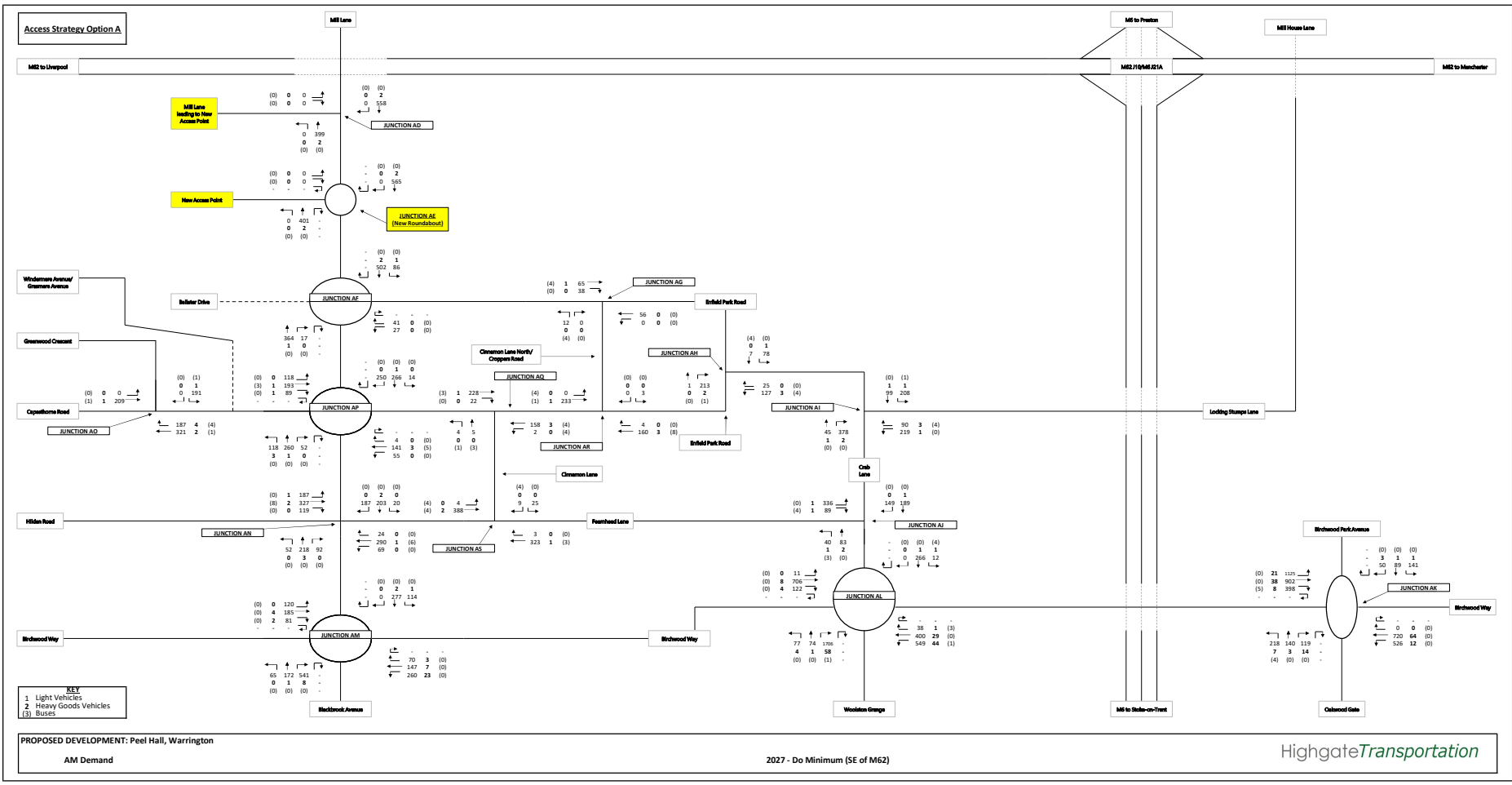

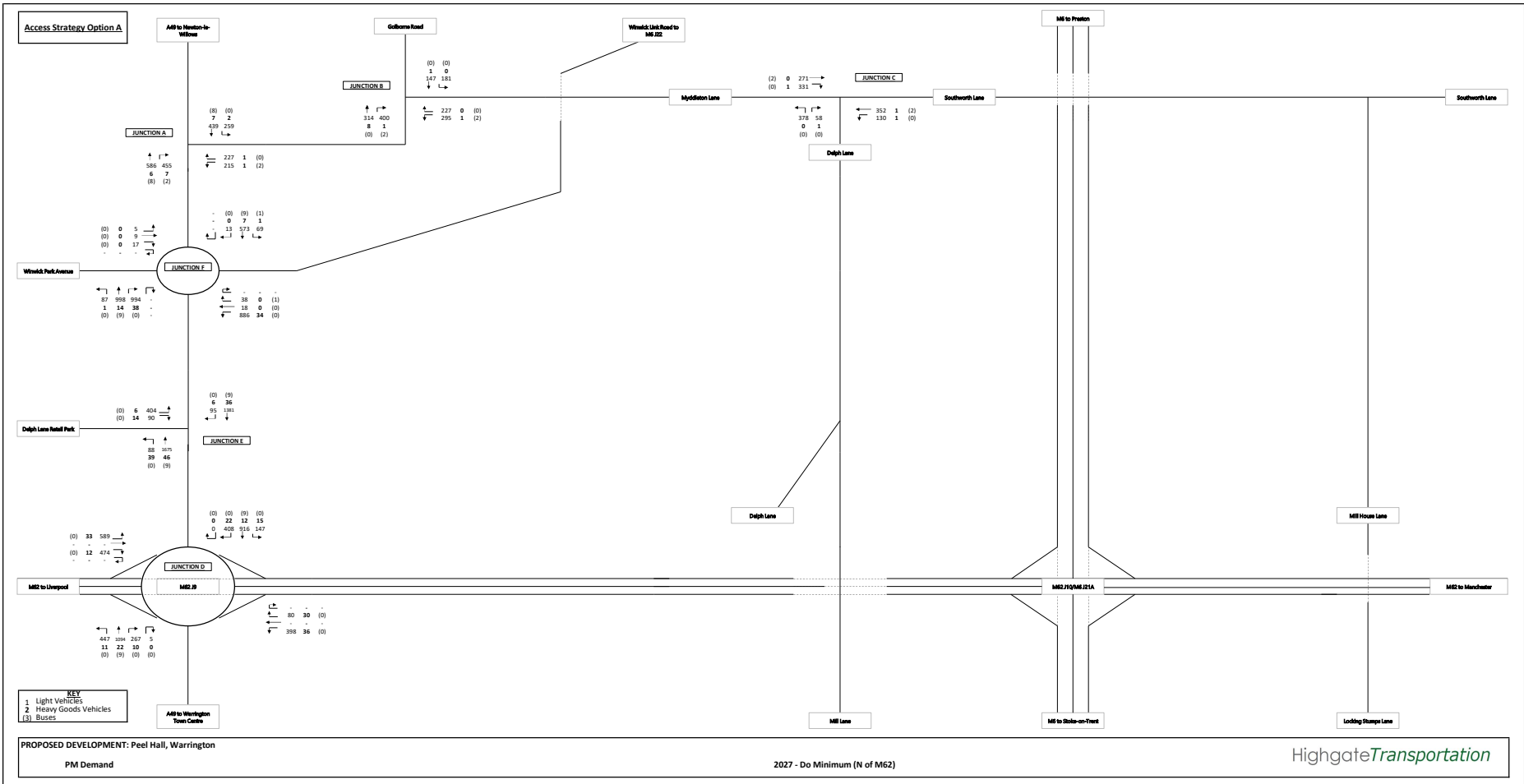

Access Strategy Option A

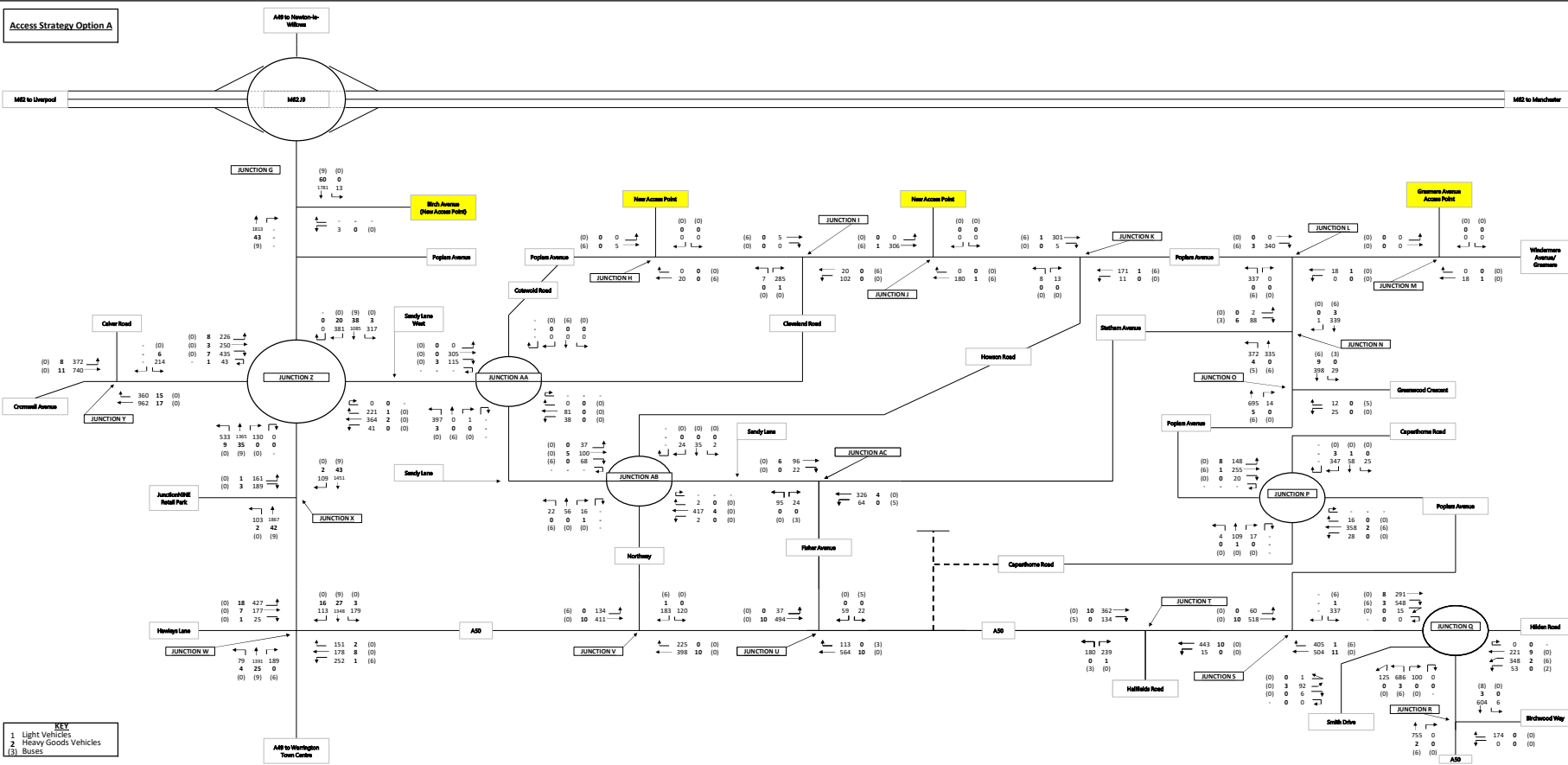

PROPOSED DEVELOPMENT: Peel Hall, Warrington
 PM Demand

2027 - Do Minimum (SW of M62)

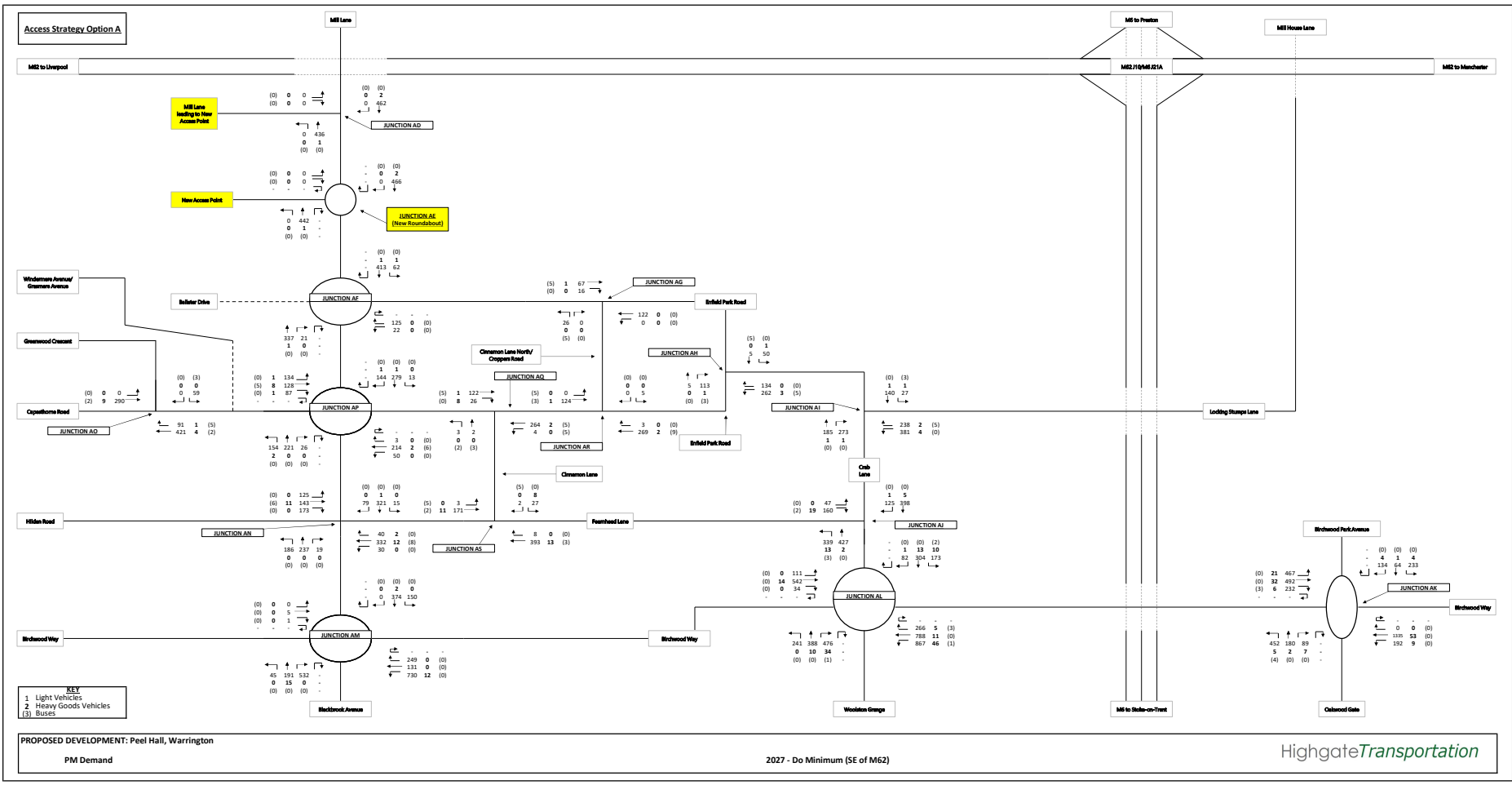

Access Strategy Option A

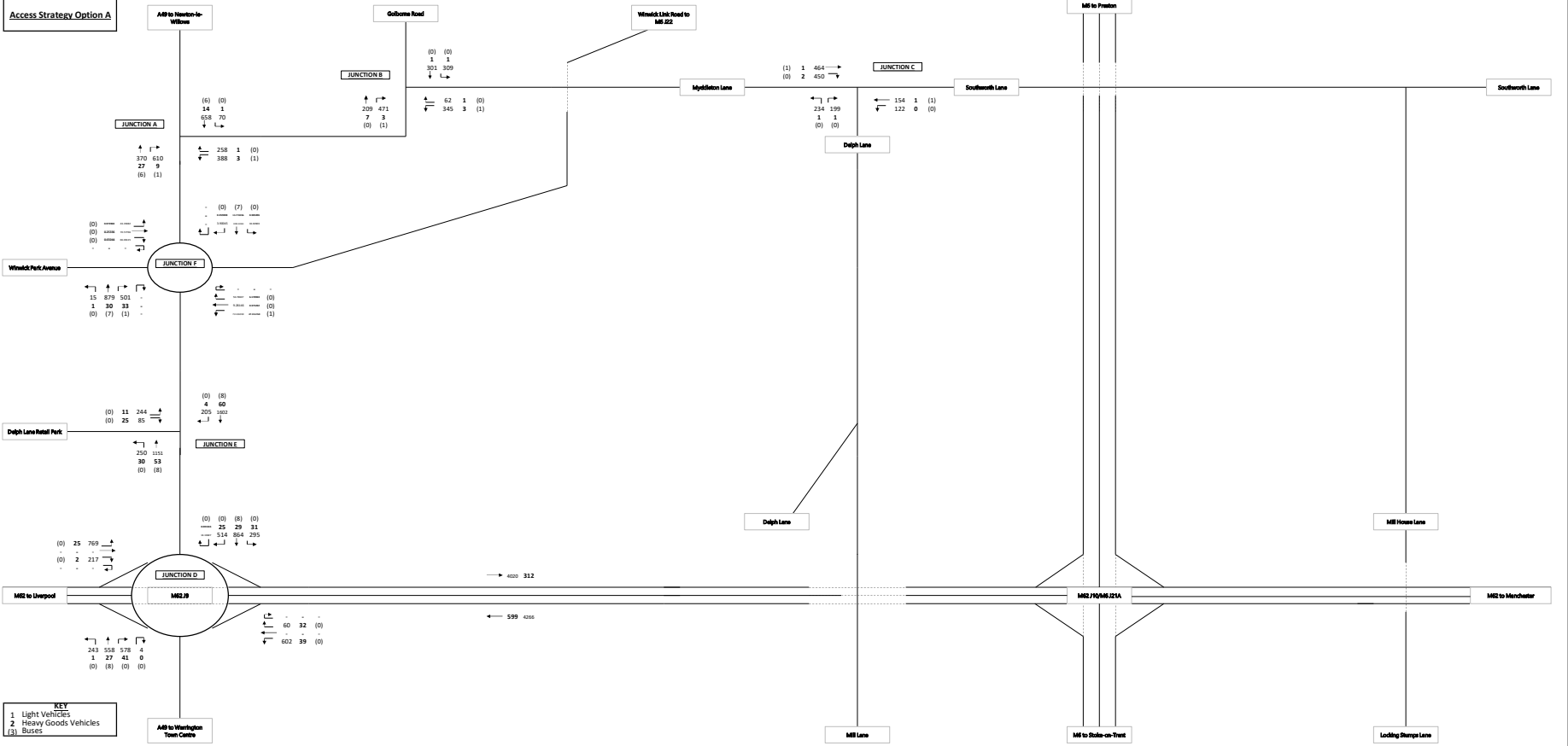

PROPOSED DEVELOPMENT: Peel Hall, Warrington
AM Demand

2027 - Do Something (N of M62)

Access Strategy Option A

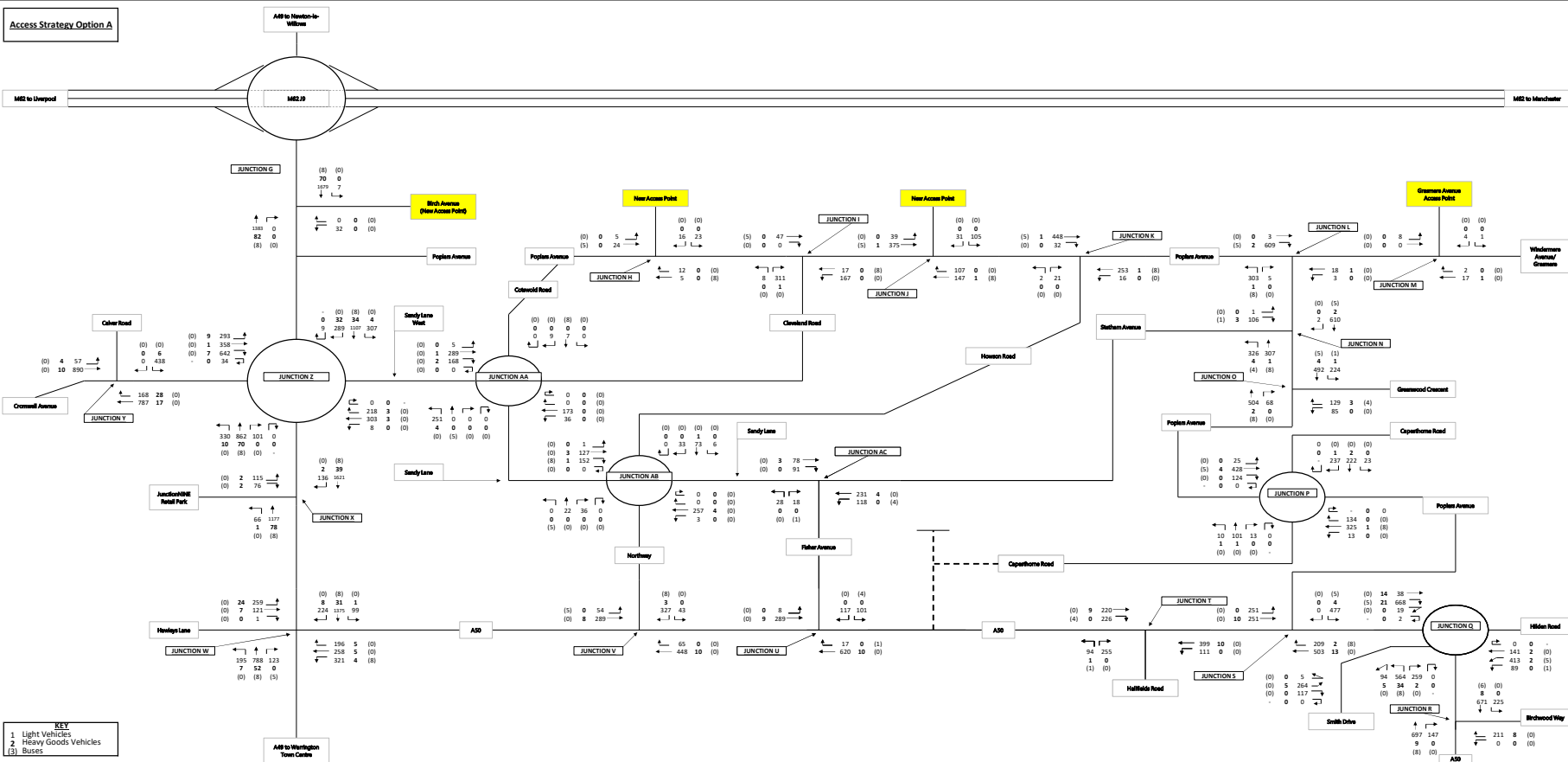

- KEY**
 1 Light Vehicles
 2 Heavy Goods Vehicles
 (3) Buses

PROPOSED DEVELOPMENT: Peel Hall, Warrington
 AM Demand

2027 - Do Something (SW of M62)

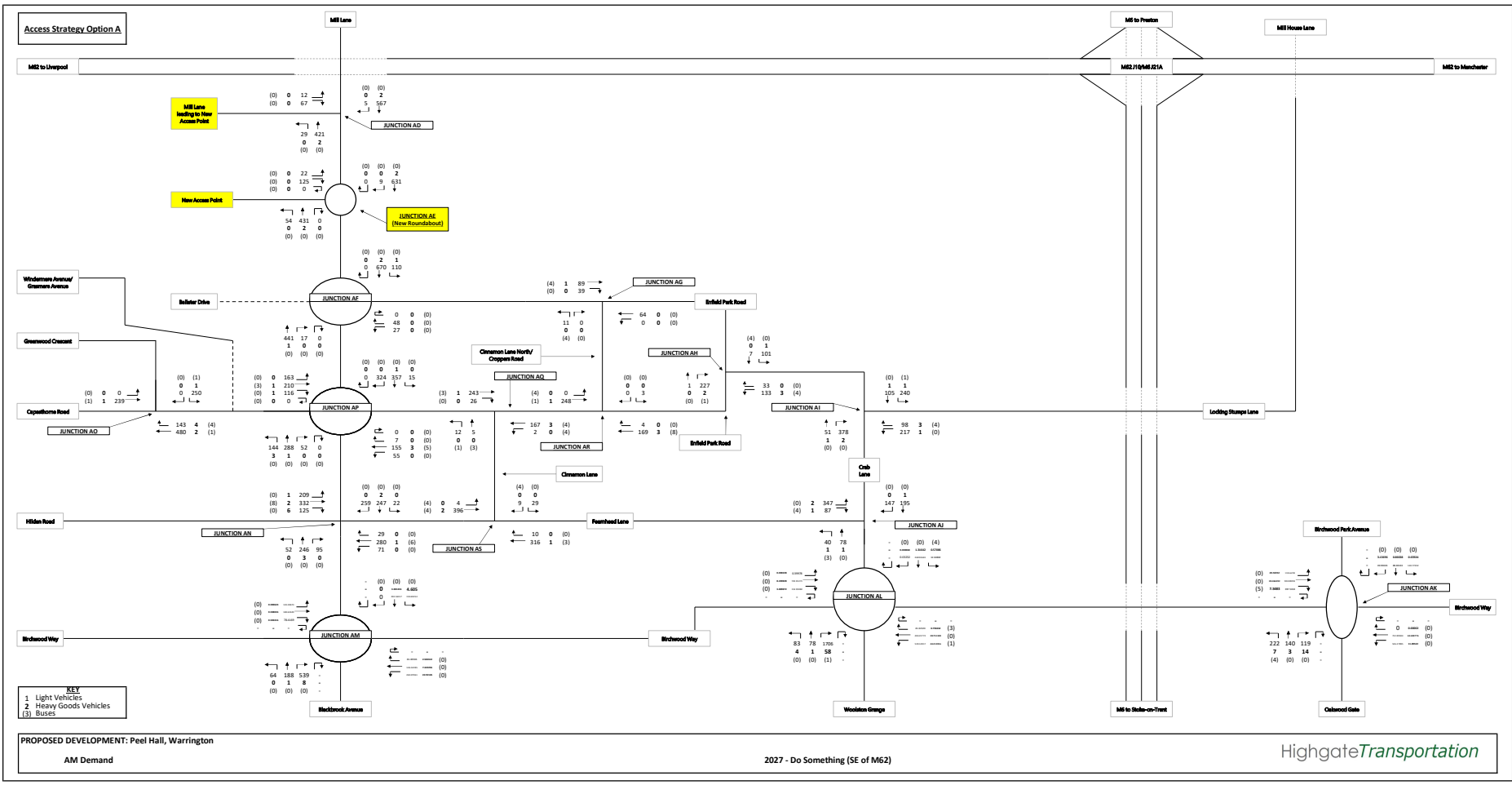

Access Strategy Option A

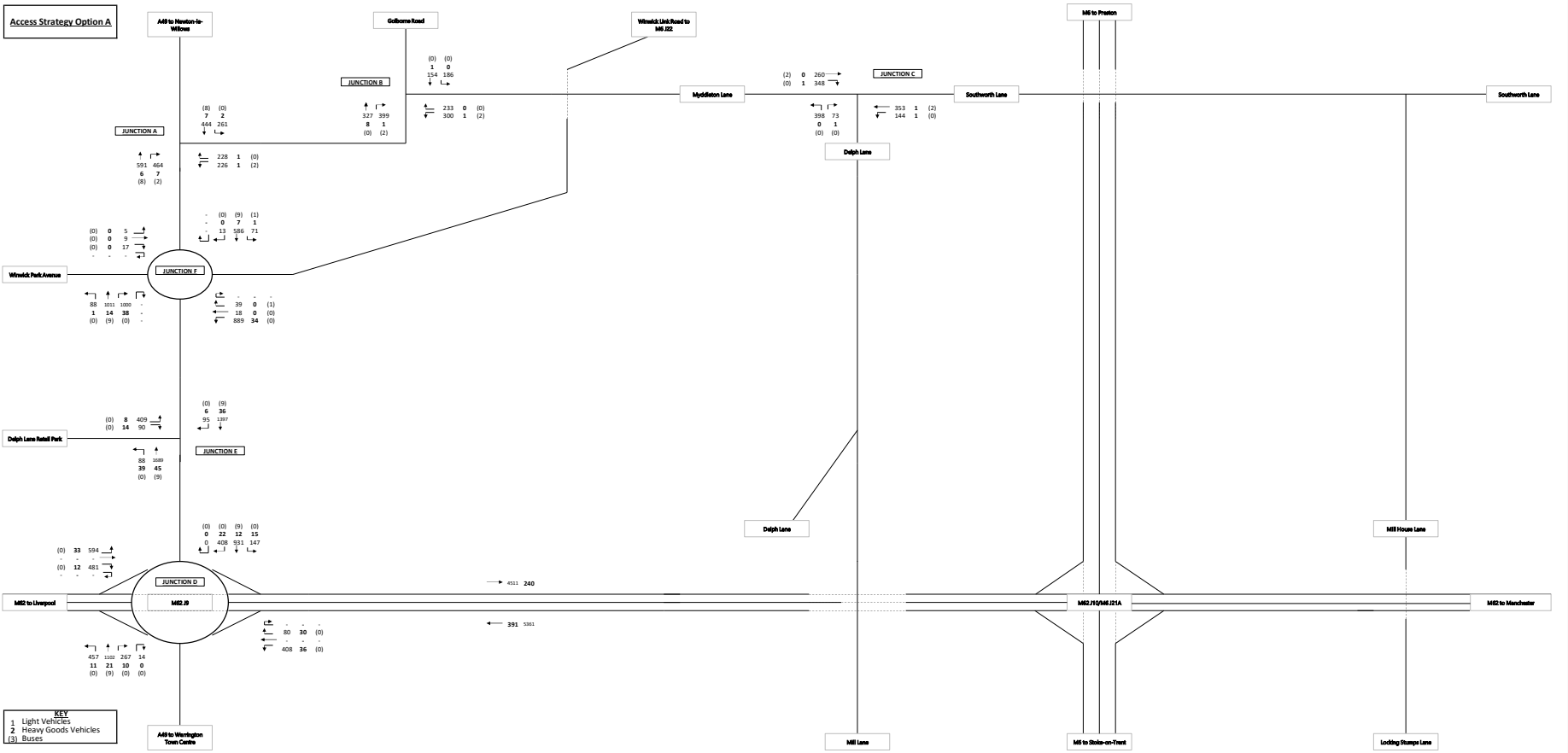

KEY
 1 Light Vehicles
 2 Heavy Goods Vehicles
 (3) Buses

PROPOSED DEVELOPMENT: Peel Hall, Warrington
 PM Demand

2027 - Do Something (N of M62)

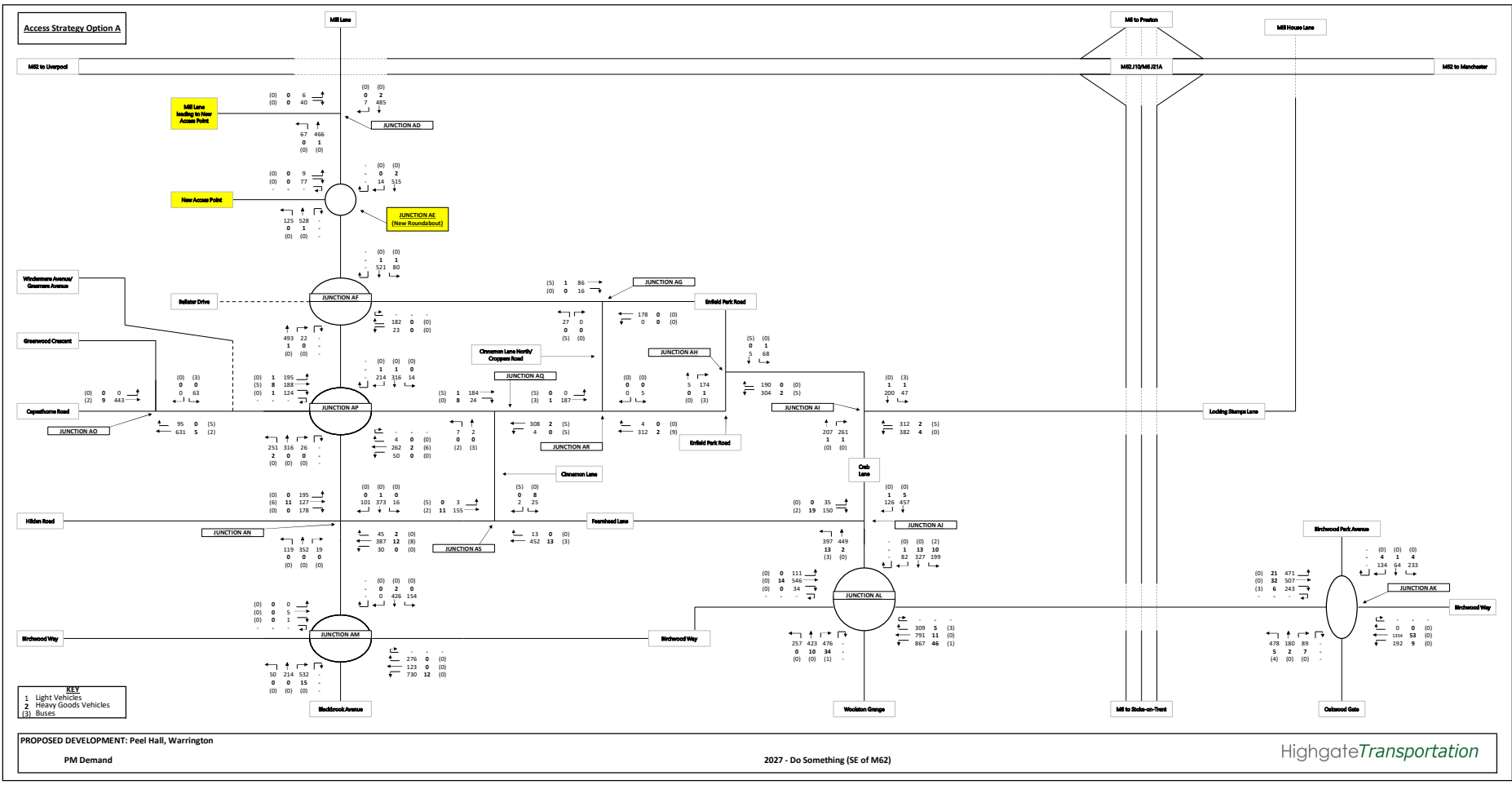

Access Strategy Option A

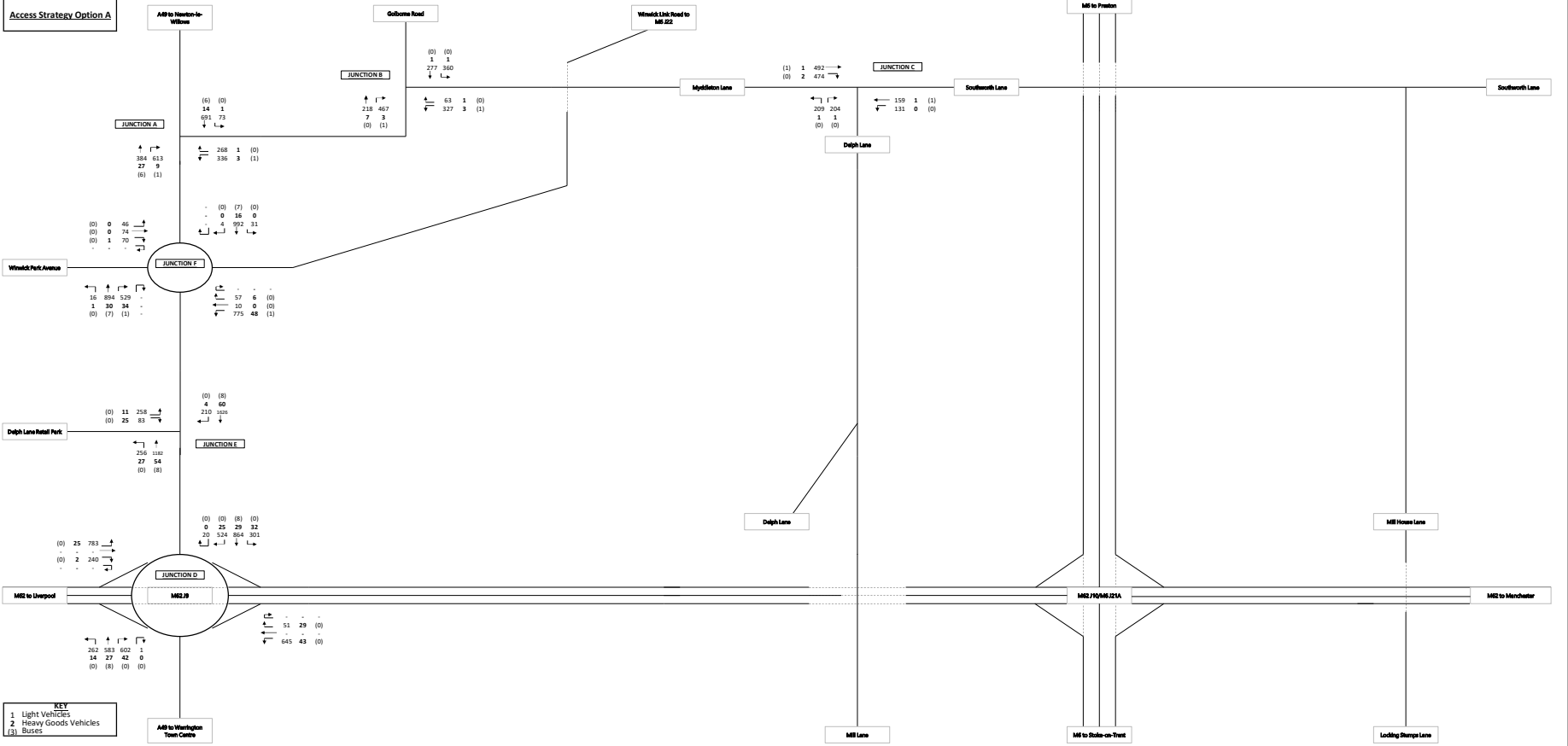

PROPOSED DEVELOPMENT: Peel Hall, Warrington
 AM Demand

2032 - Do Minimum (N of M62)

Access Strategy Option A

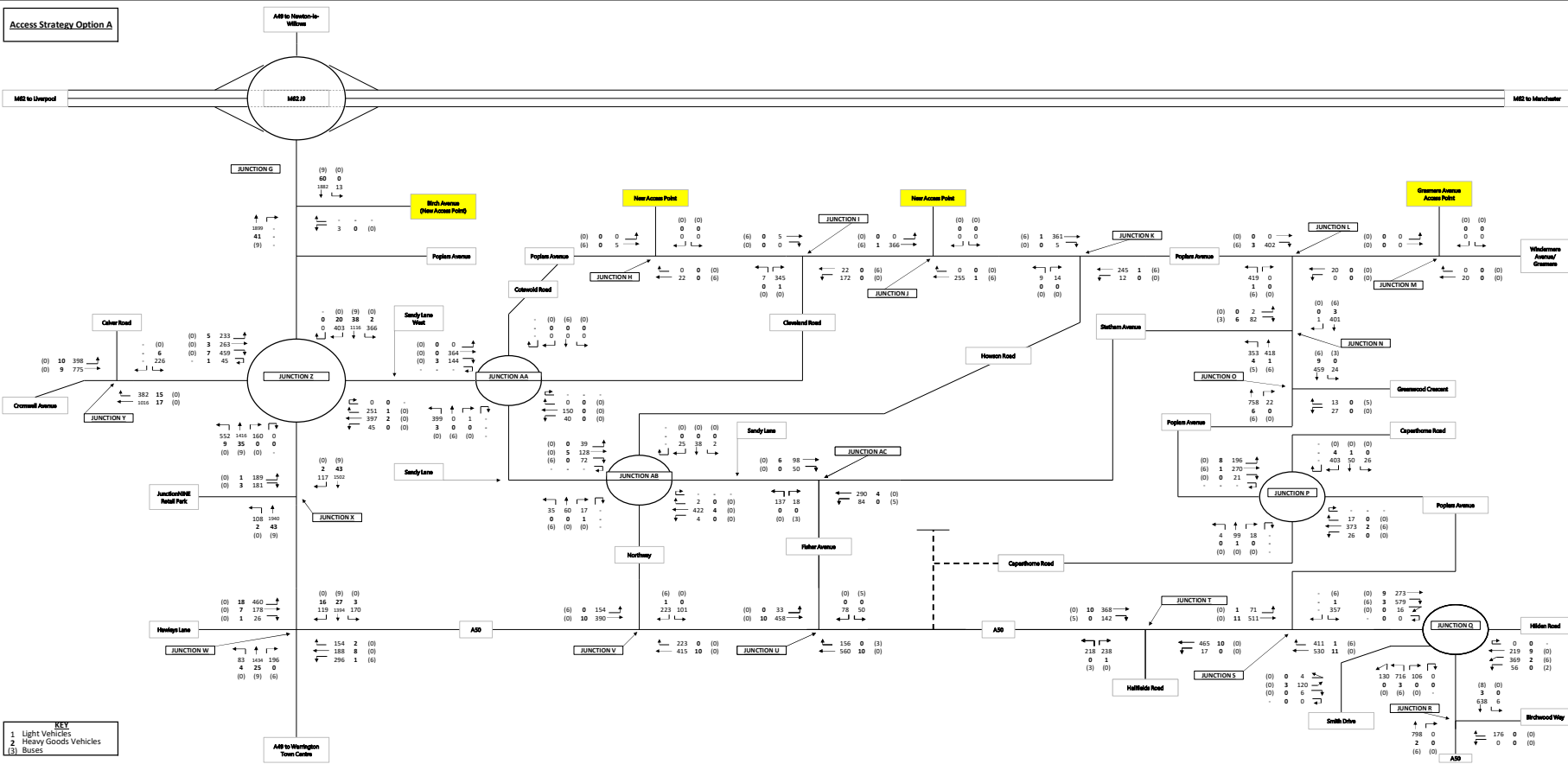

PROPOSED DEVELOPMENT: Peel Hall, Warrington
PM Demand

2032 - Do Minimum (SW of M62)

Access Strategy Option A

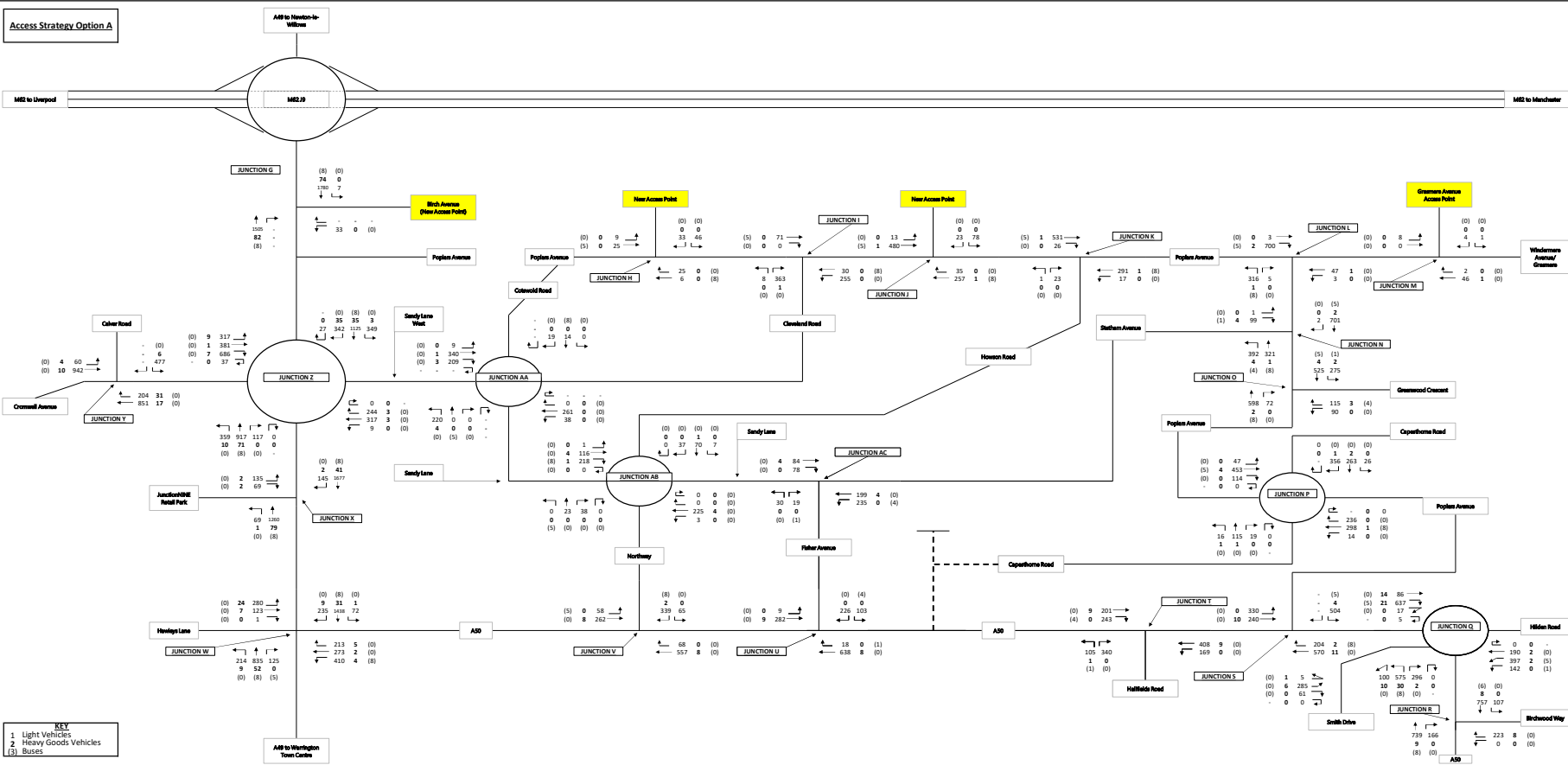

KEY
 1 Light Vehicles
 2 Heavy Goods Vehicles
 3 Buses

PROPOSED DEVELOPMENT: Peel Hall, Warrington
 AM Demand

2032 - Do Something (FULL Development) (SW of M62)

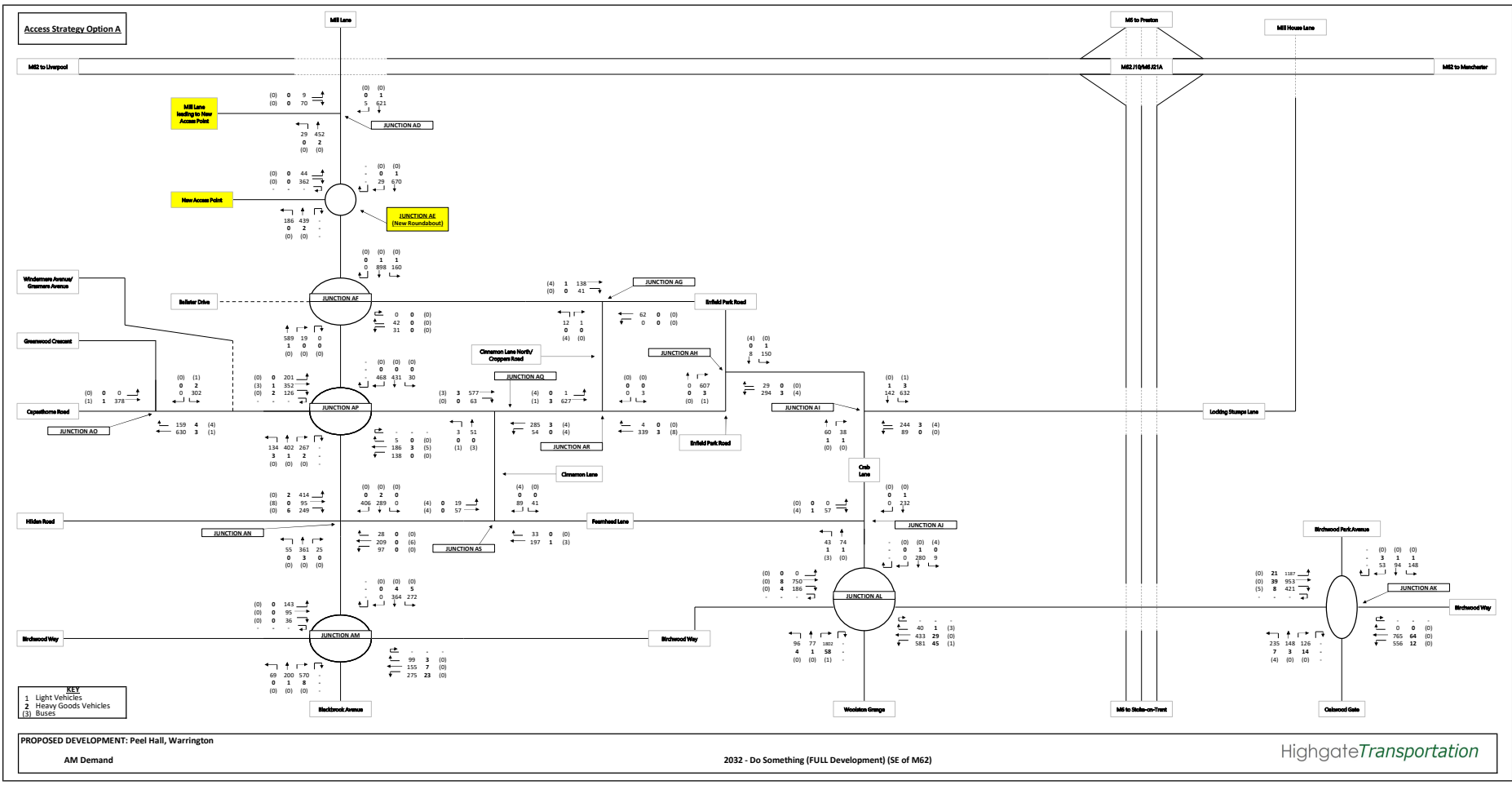

Access Strategy Option A

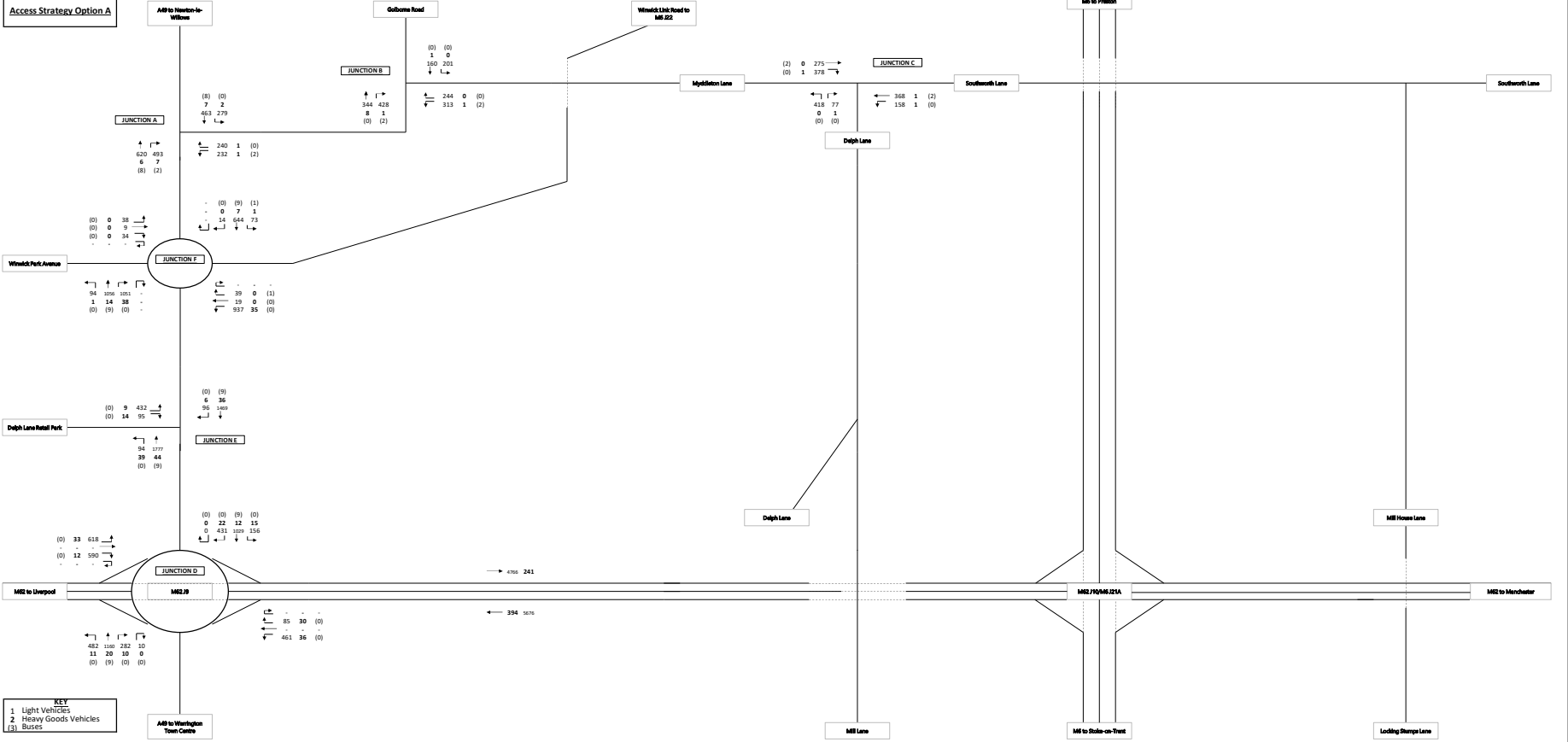

PROPOSED DEVELOPMENT: Peel Hall, Warrington
PM Demand

2032 - Do Something (FULL Development) (N of M62)

Access Strategy Option A

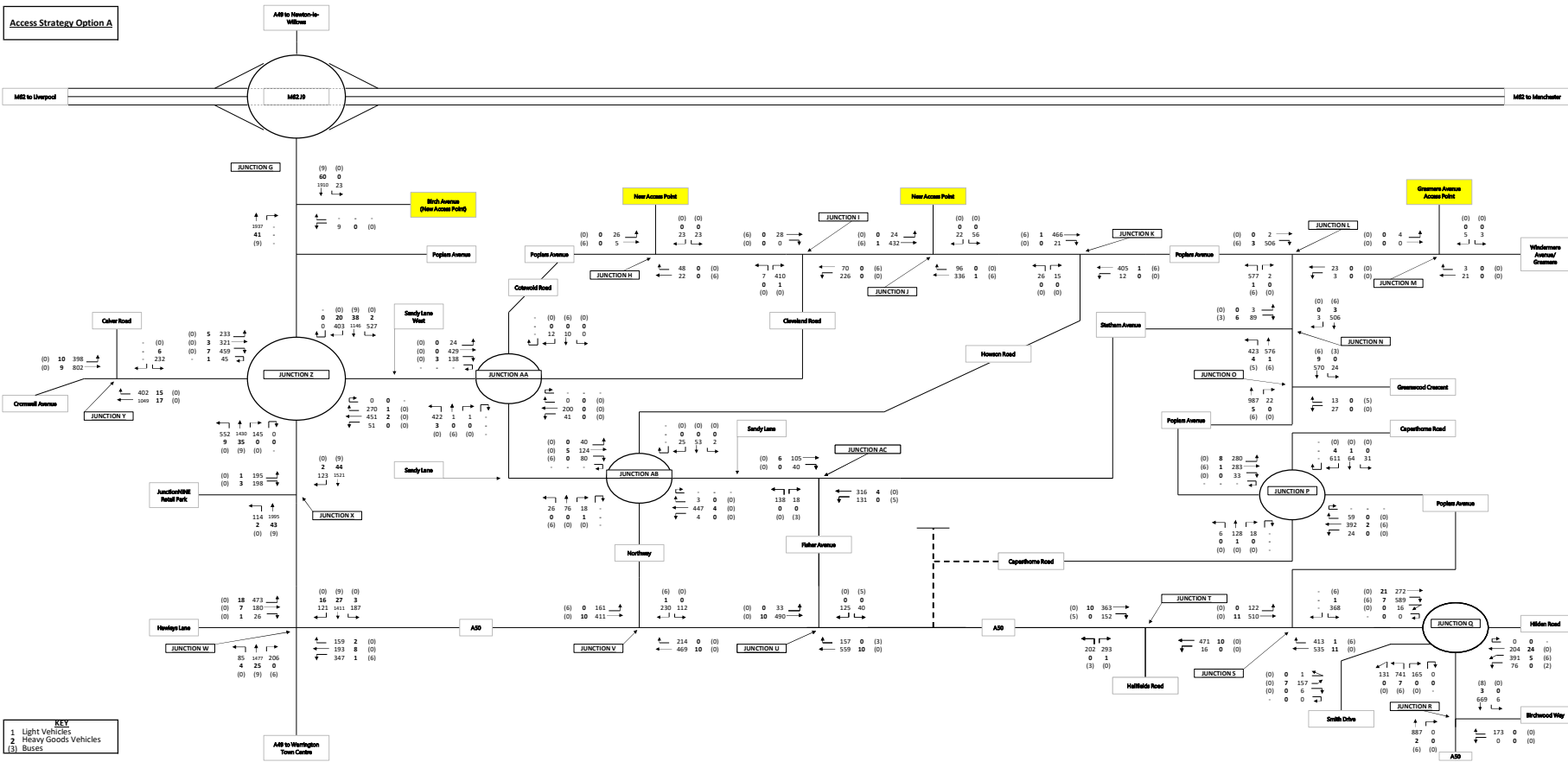

KEY
 1 Light Vehicles
 2 Heavy Goods Vehicles
 3 Buses

PROPOSED DEVELOPMENT: Peel Hall, Warrington
 PM Demand

2032 - Do Something (FULL Development) (SW of M62)

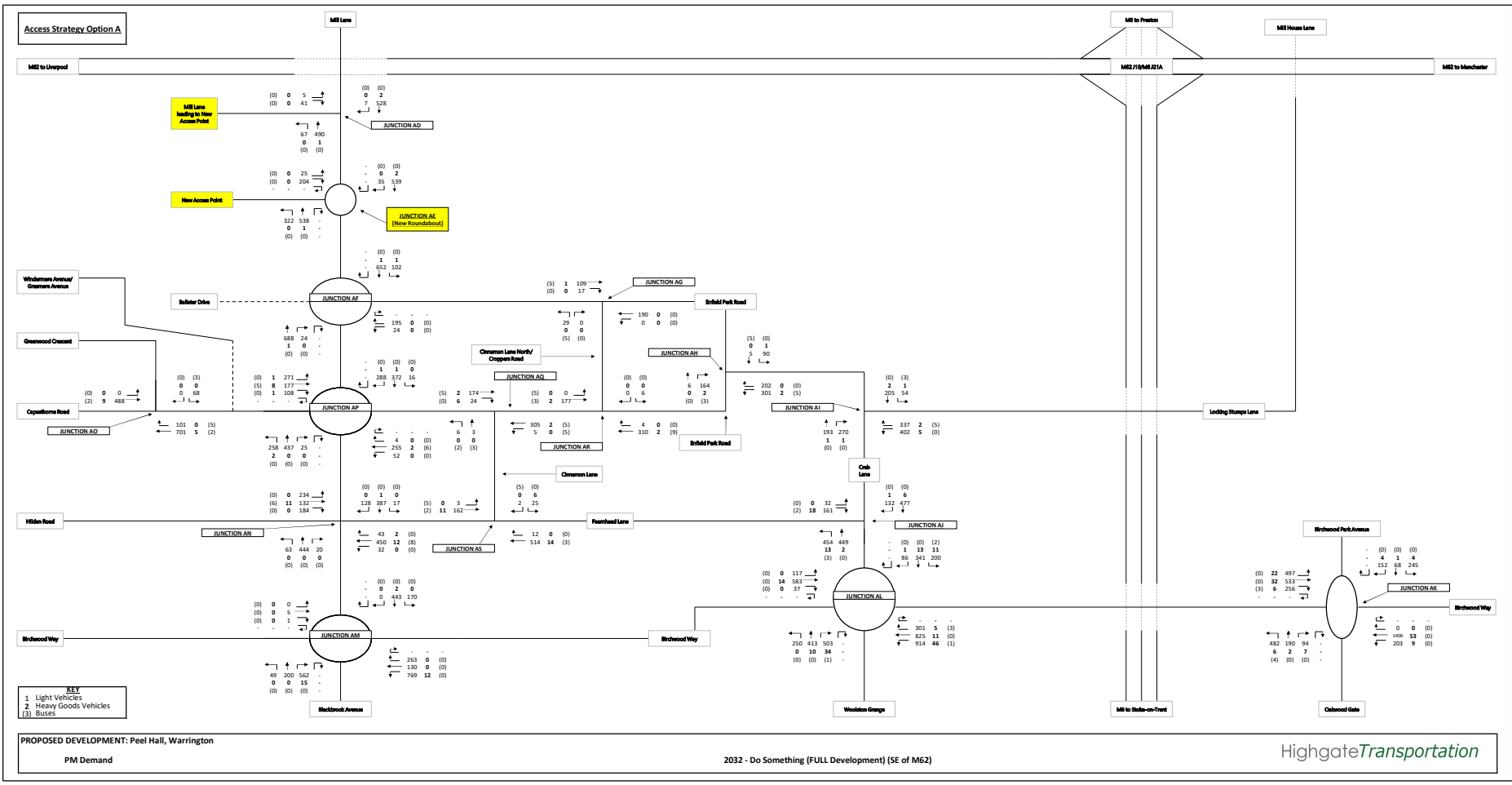

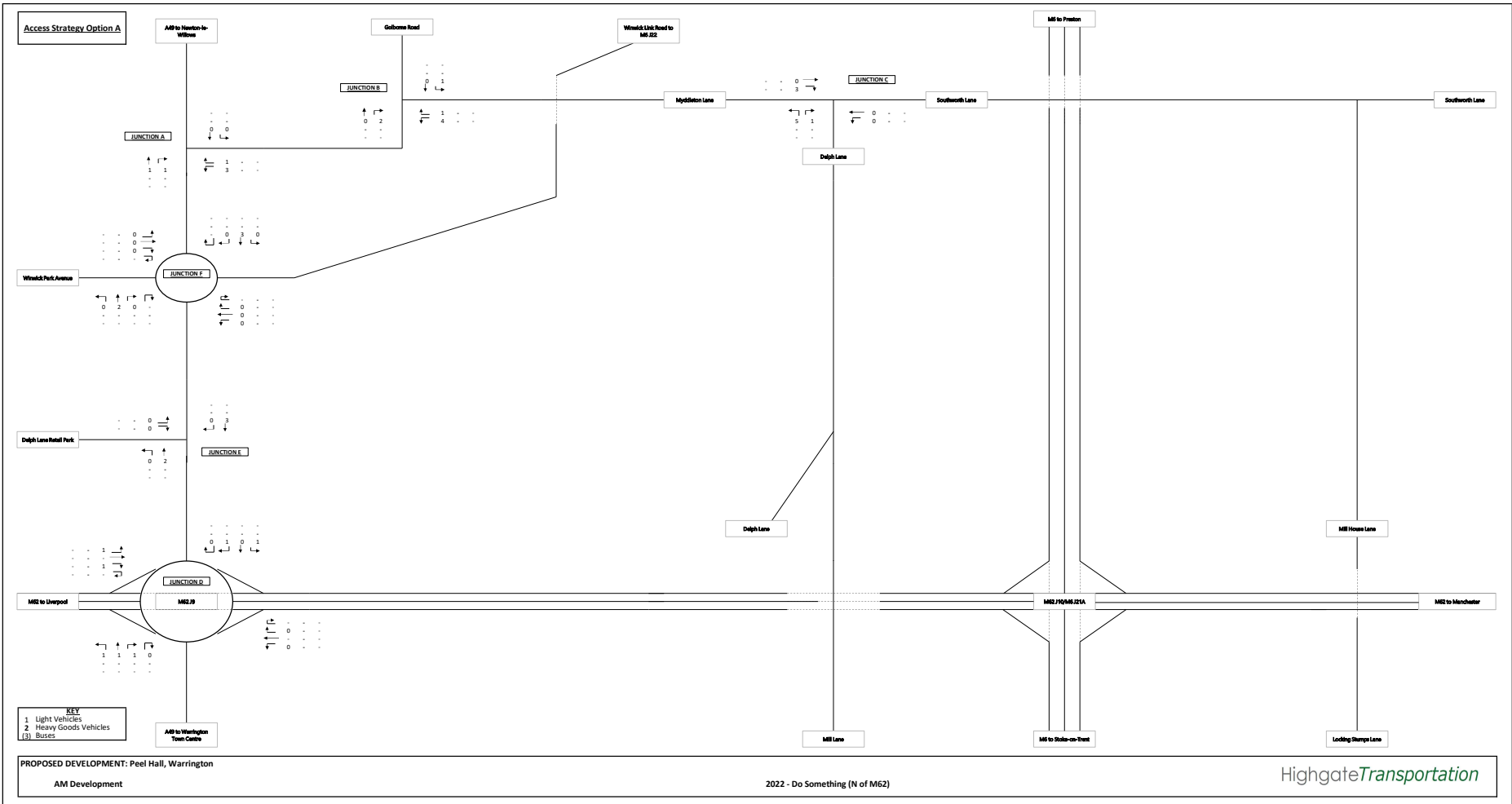

Access Strategy Option A

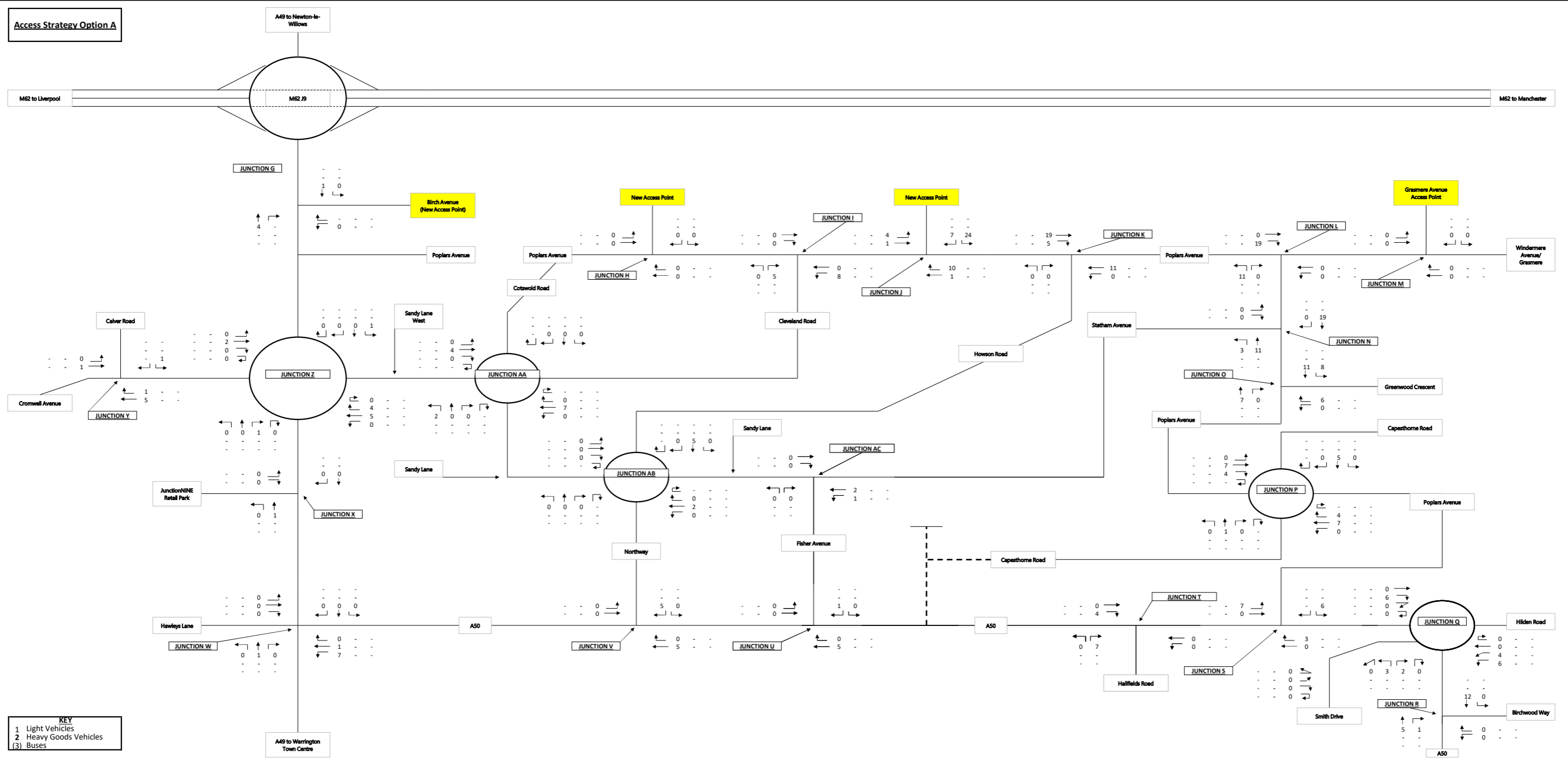

KEY

1	Light Vehicles
2	Heavy Goods Vehicles
3	Buses

PROPOSED DEVELOPMENT: Peel Hall, Warrington
AM Development

2022 - Do Something (SW of M62)

Access Strategy Option A

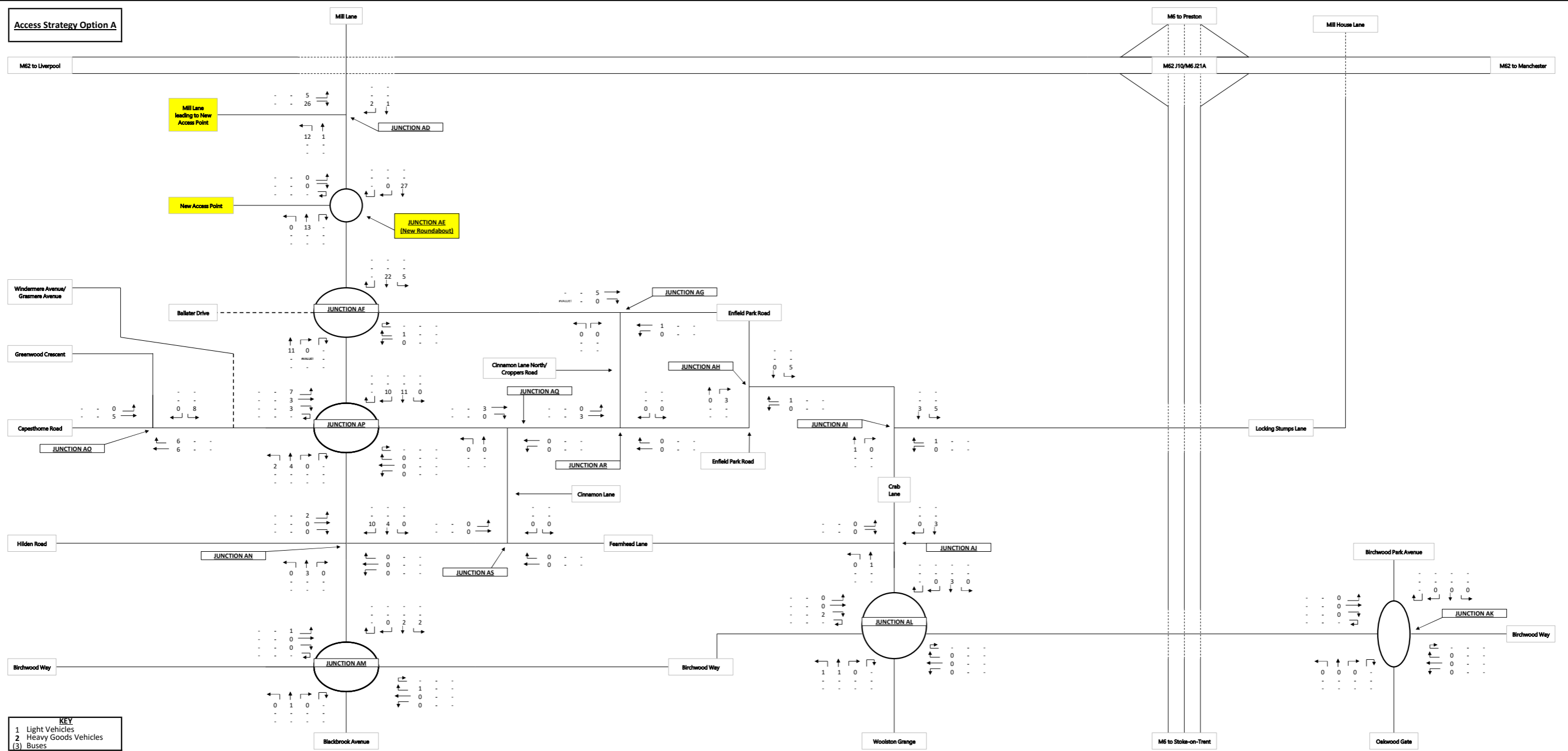

- KEY**
- 1 Light Vehicles
 - 2 Heavy Goods Vehicles
 - (3) Buses

PROPOSED DEVELOPMENT: Peel Hall, Warrington
AM Development

2022 - Do Something (SE of M62)

Access Strategy Option A

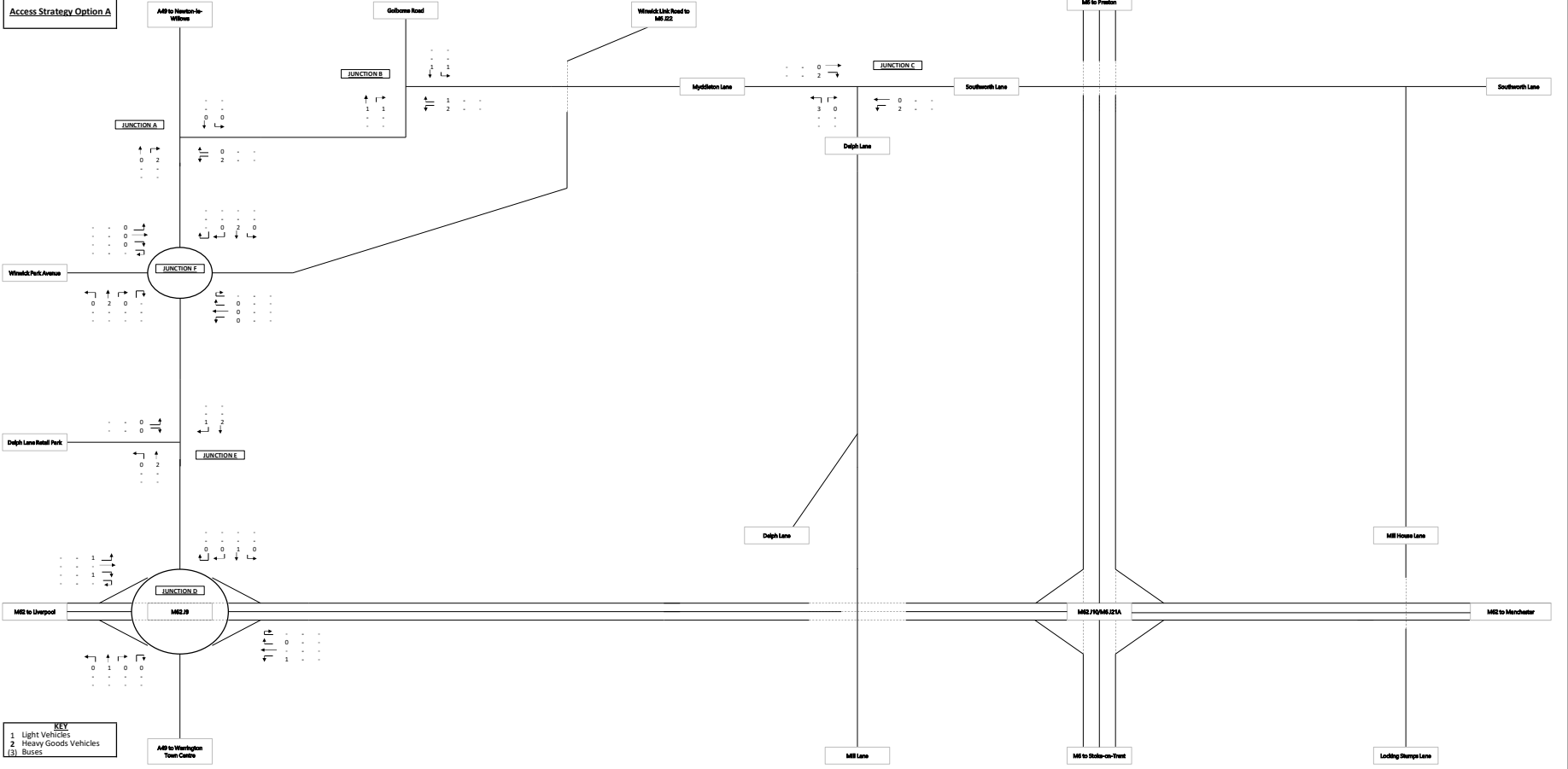

PROPOSED DEVELOPMENT: Peel Hall, Warrington
PM Development

Access Strategy Option A

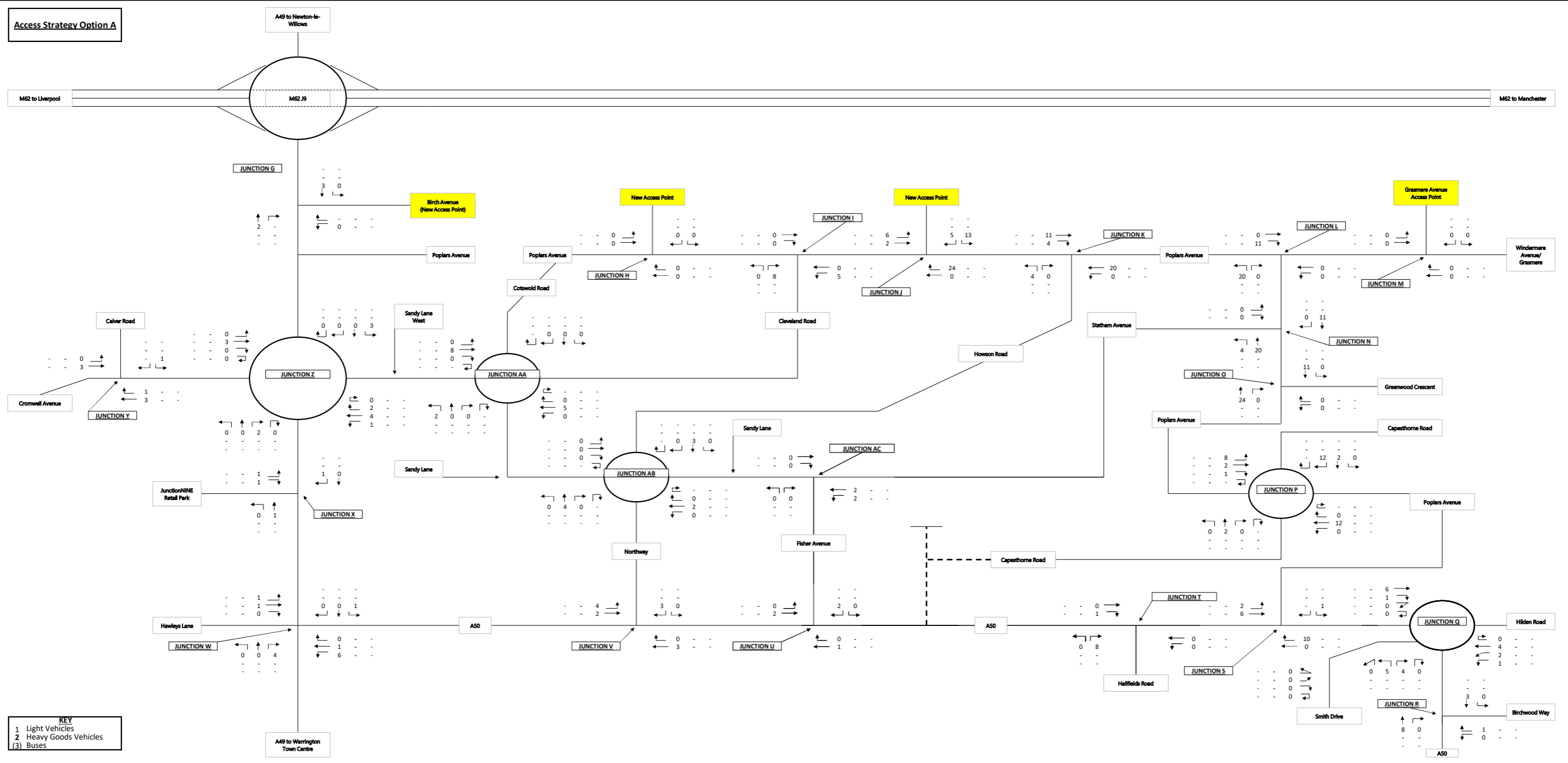

KEY

1	Light Vehicles
2	Heavy Goods Vehicles
3	Buses

PROPOSED DEVELOPMENT: Peel Hall, Warrington
PM Development

2022 - Do Something (SW of M62)

HighgateTransportation

Access Strategy Option A

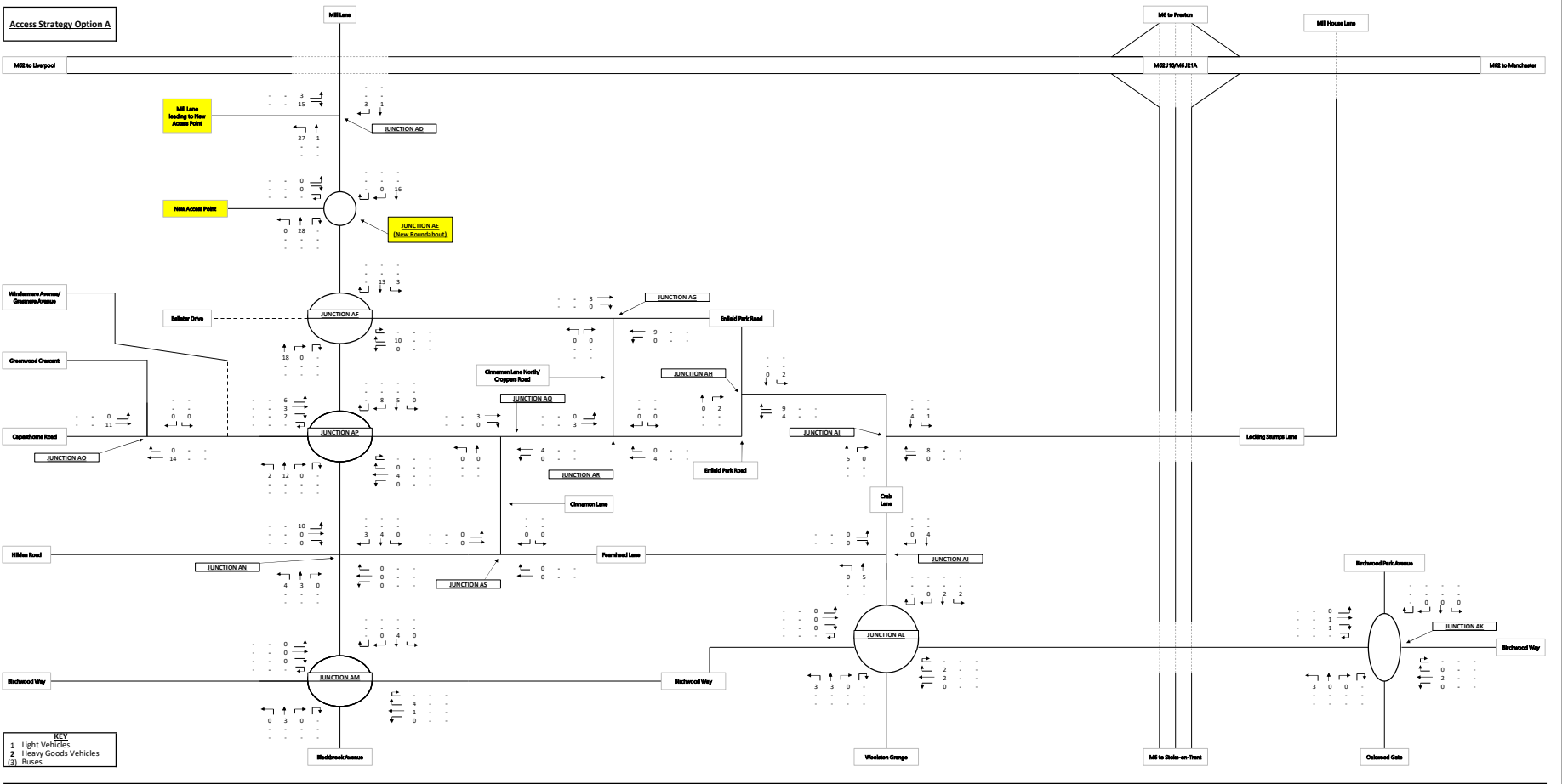

PROPOSED DEVELOPMENT: Peel Hall, Warrington
PM Development

2022 - Do Something (SE of M62)

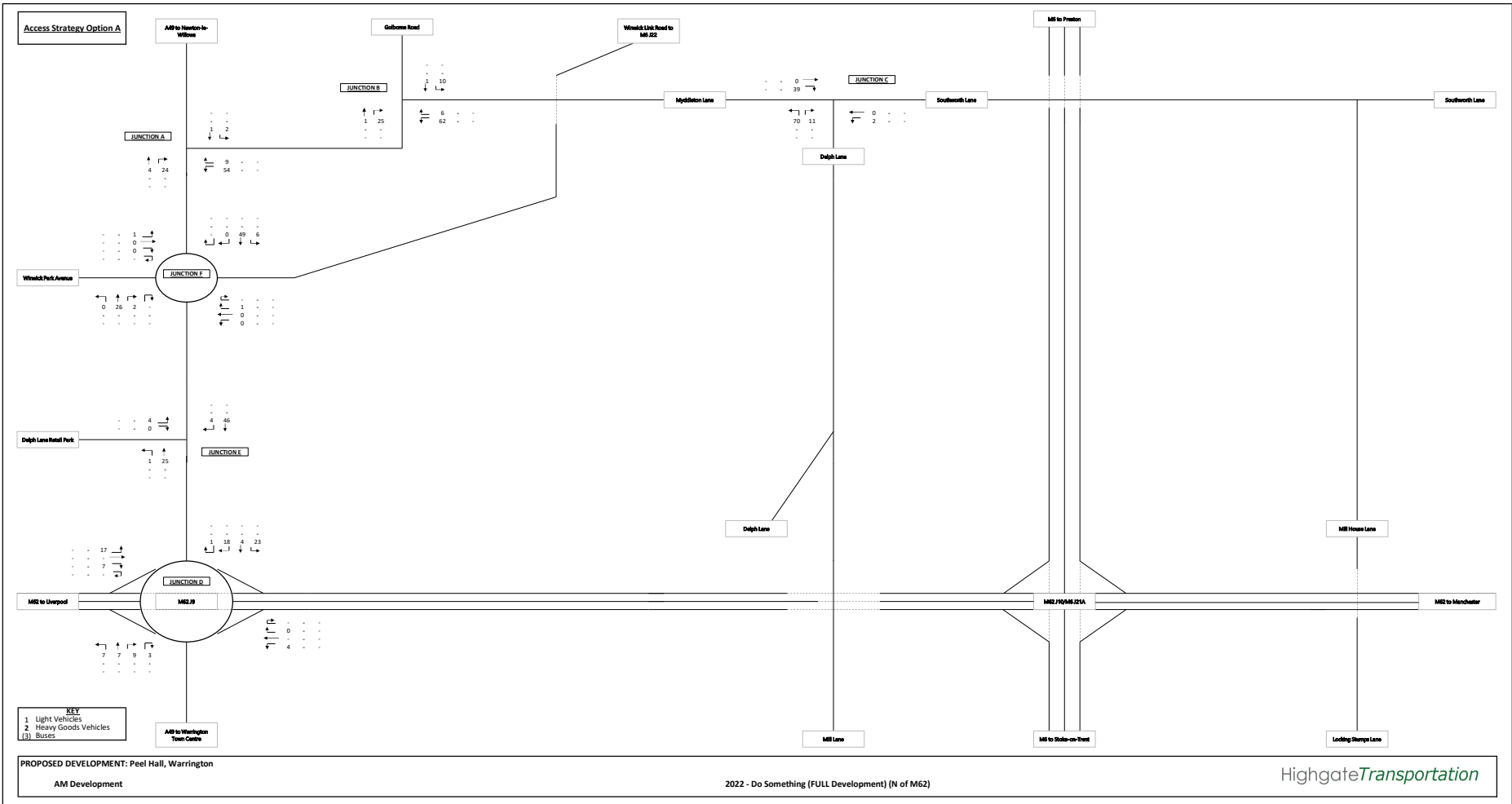

Access Strategy Option A

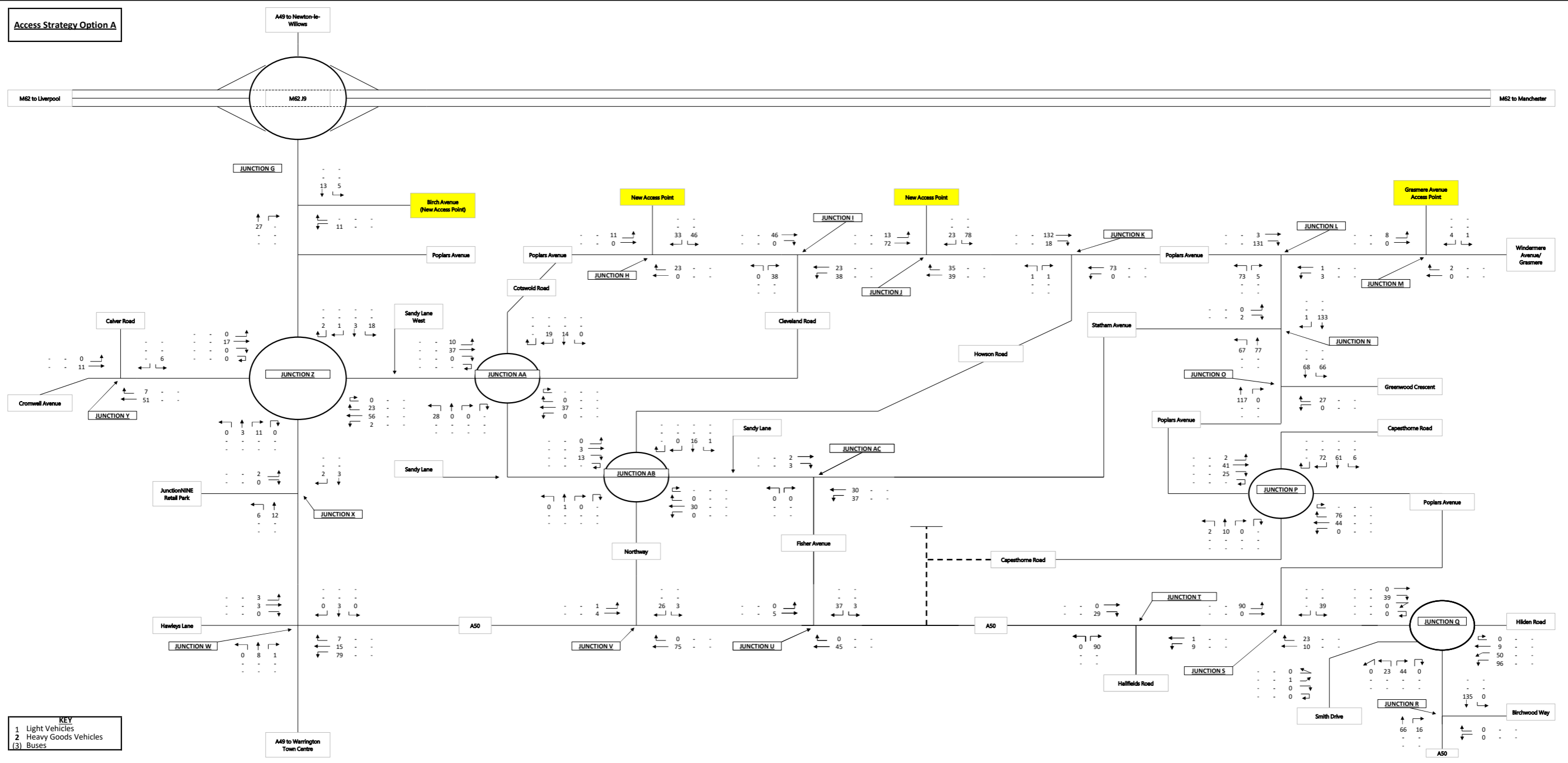

KEY
 1 Light Vehicles
 2 Heavy Goods Vehicles
 3 Buses

PROPOSED DEVELOPMENT: Peel Hall, Warrington
 AM Development

2022 - Do Something (FULL Development) (SW of M62)

Access Strategy Option A

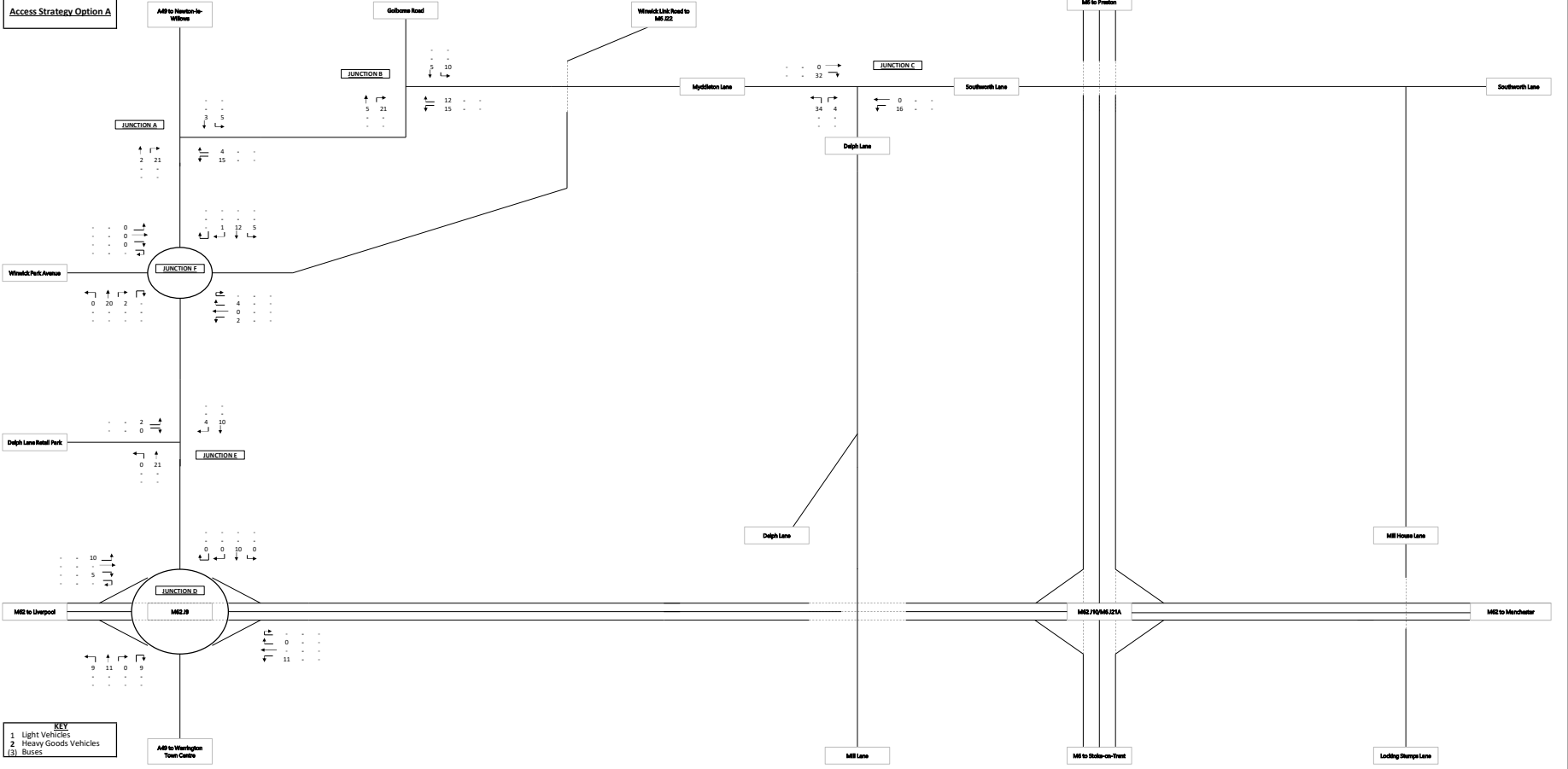

PROPOSED DEVELOPMENT: Peel Hall, Warrington
 PM Development

Access Strategy Option A

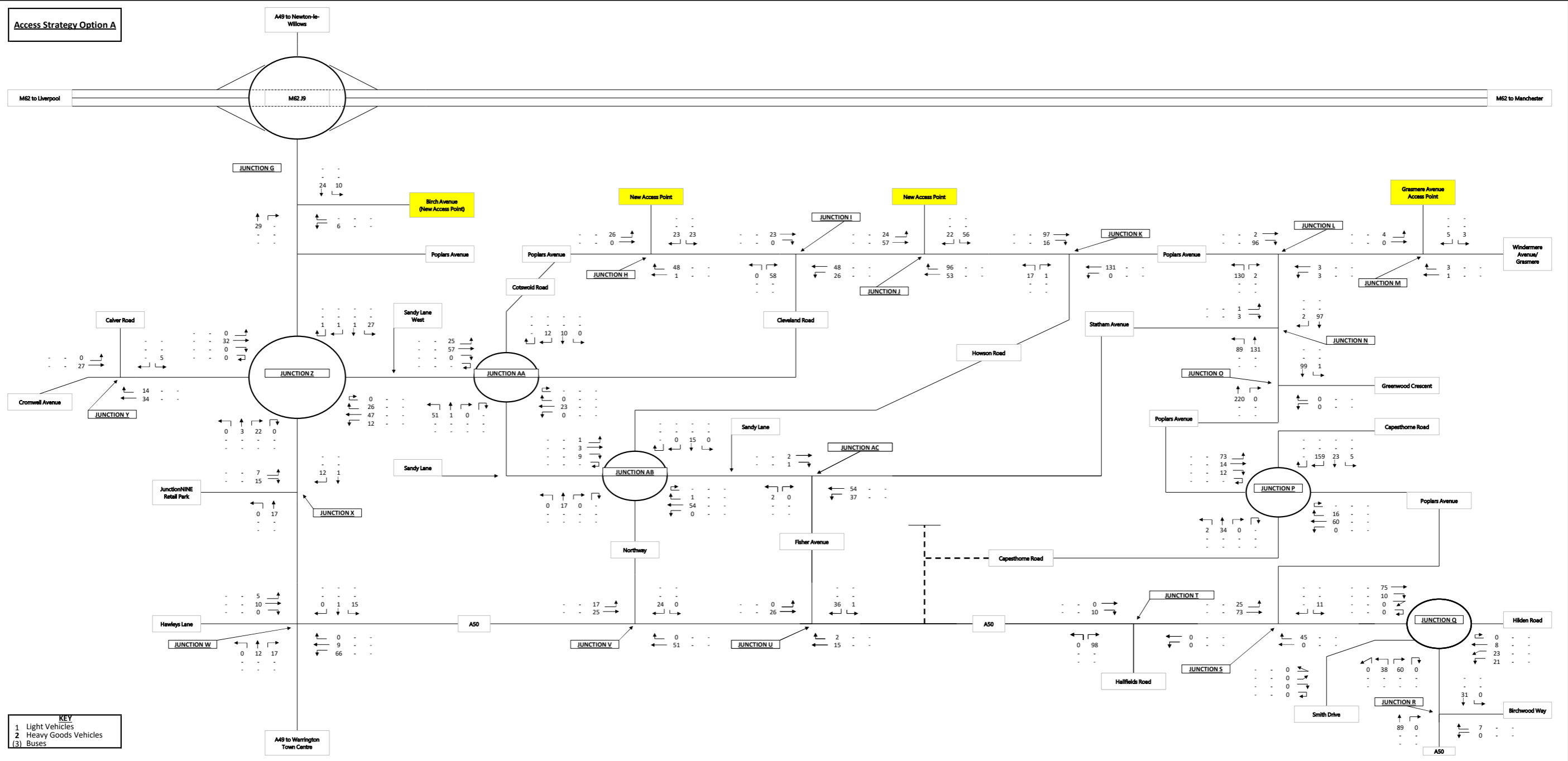

KEY
 1 Light Vehicles
 2 Heavy Goods Vehicles
 (3) Buses

PROPOSED DEVELOPMENT: Peel Hall, Warrington
 PM Development

2022 - Do Something (FULL Development) (SW of M62)

HighgateTransportation

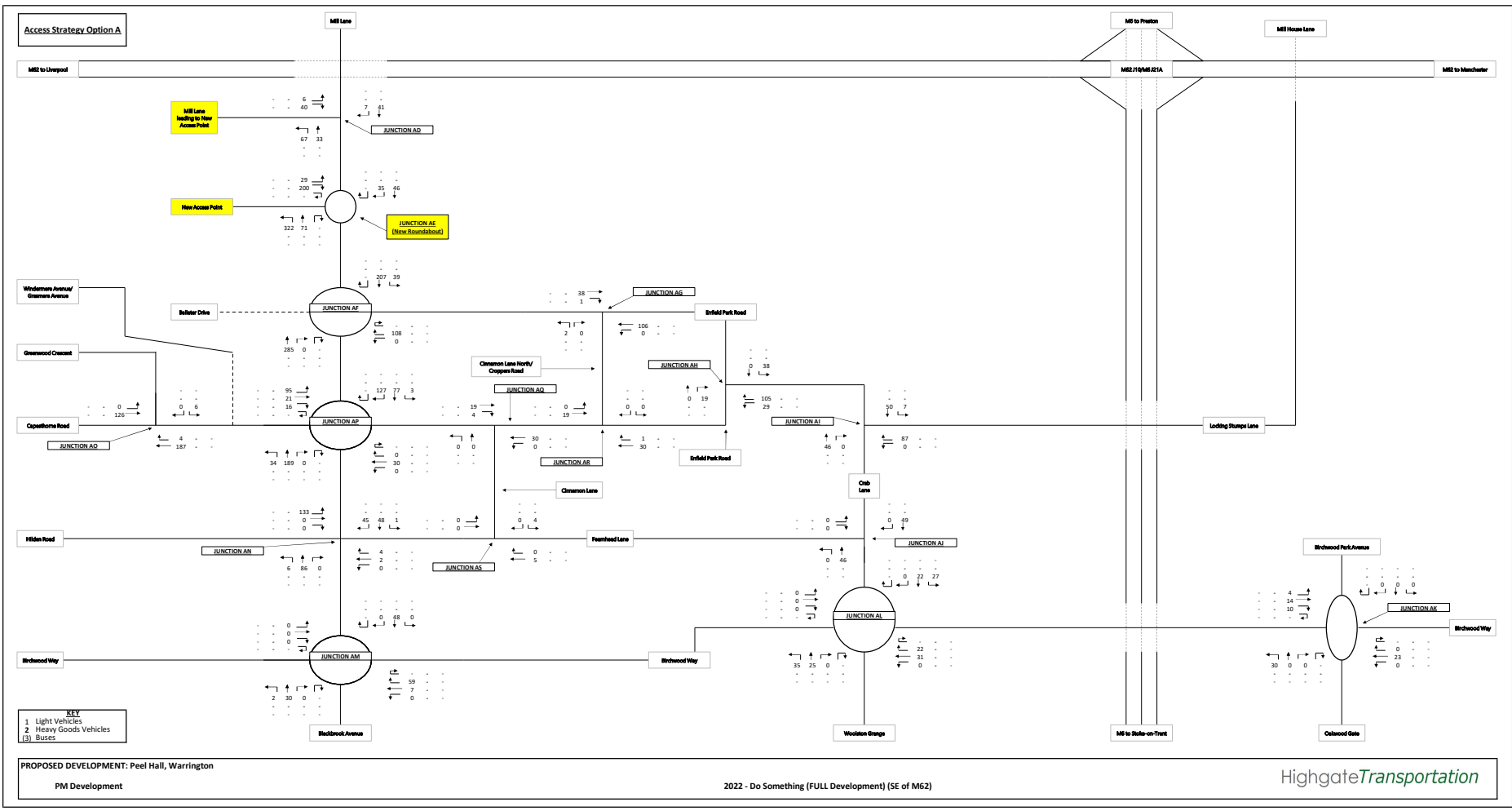

Access Strategy Option A

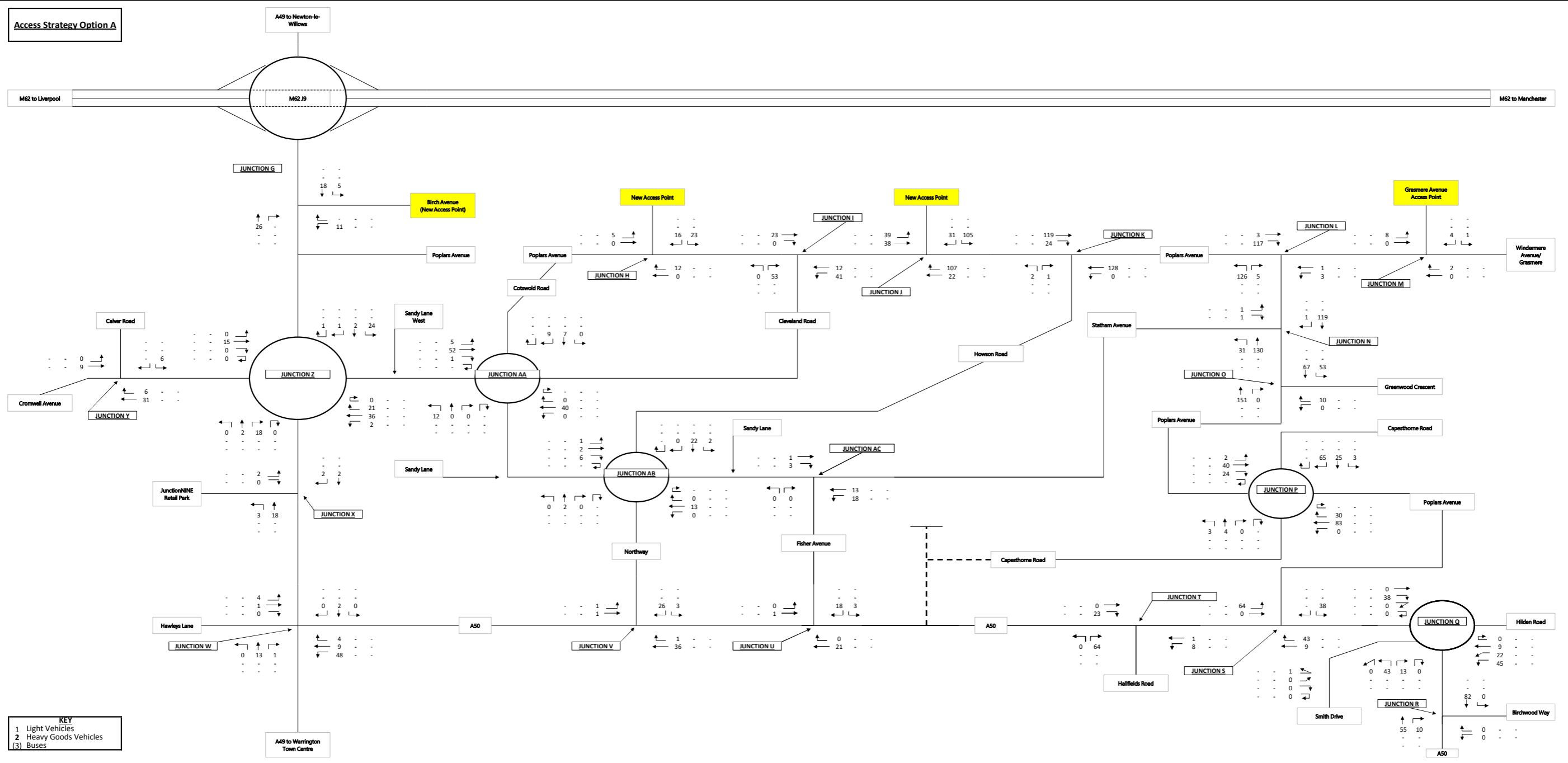

KEY
 1 Light Vehicles
 2 Heavy Goods Vehicles
 3 Buses

PROPOSED DEVELOPMENT: Peel Hall, Warrington
 AM Development

2027 - Do Something (SW of M62)

HighgateTransportation

Access Strategy Option A

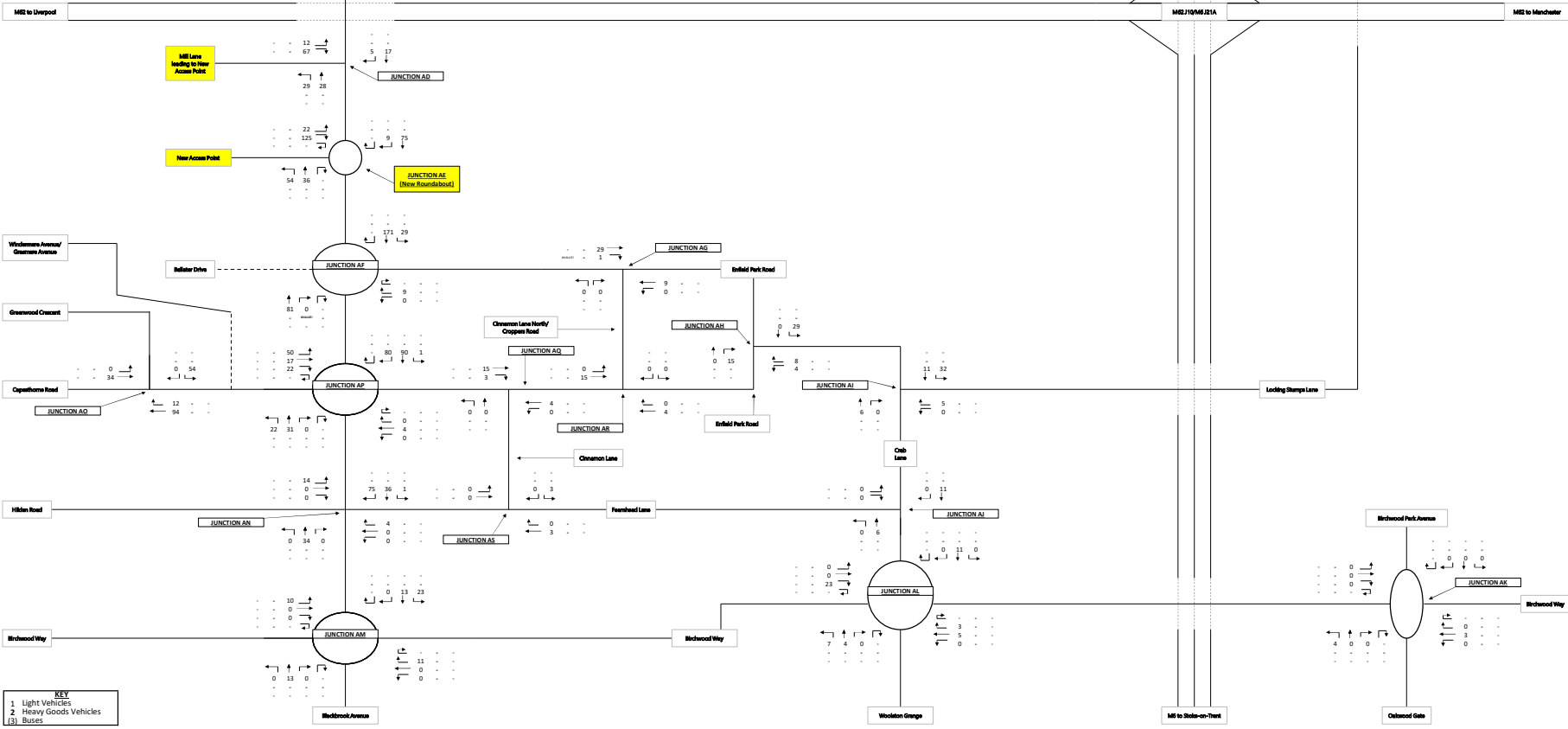

PROPOSED DEVELOPMENT: Peel Hall, Warrington
AM Development

2027 - Do Something (SE of M62)

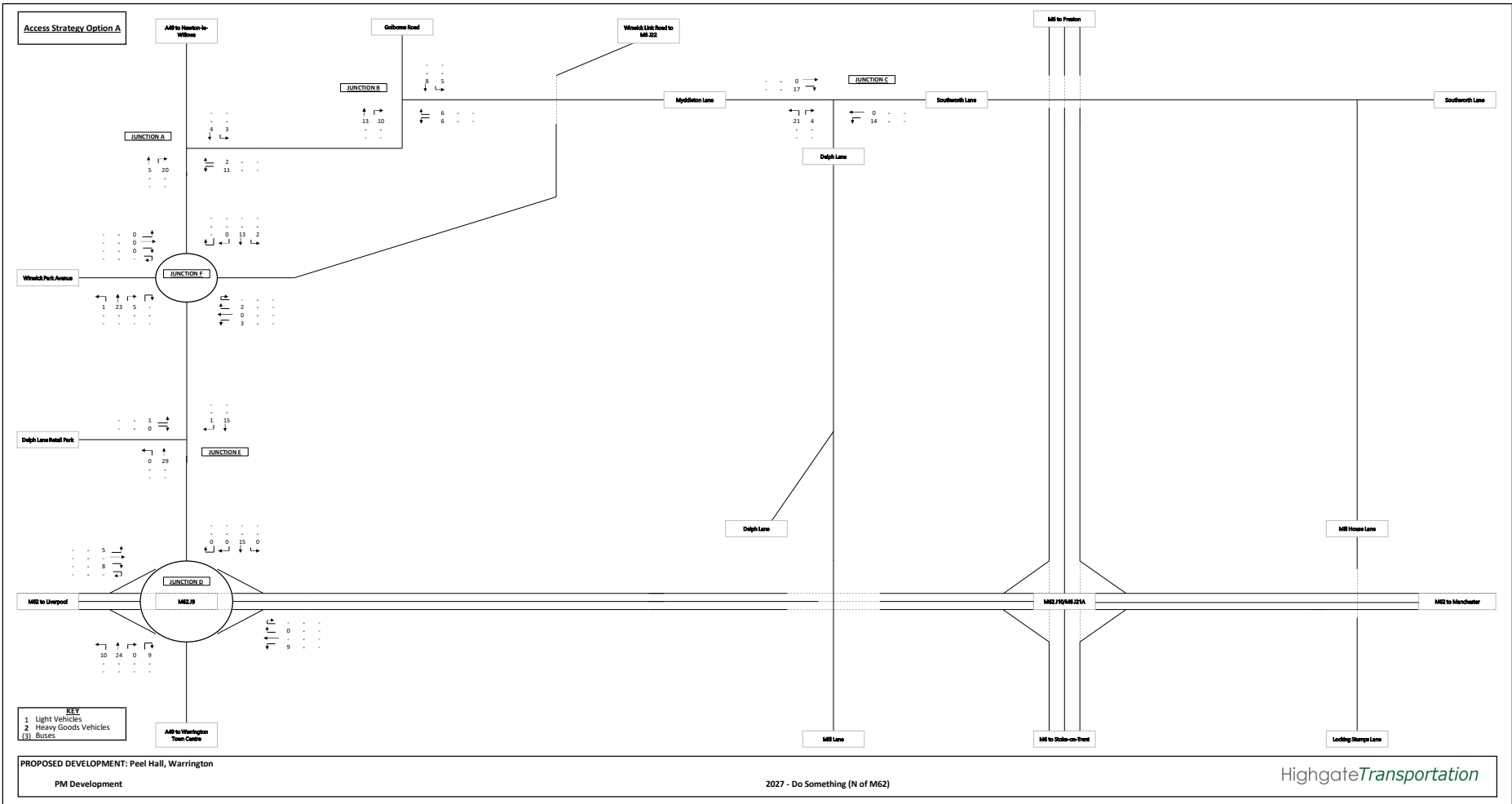

Access Strategy Option A

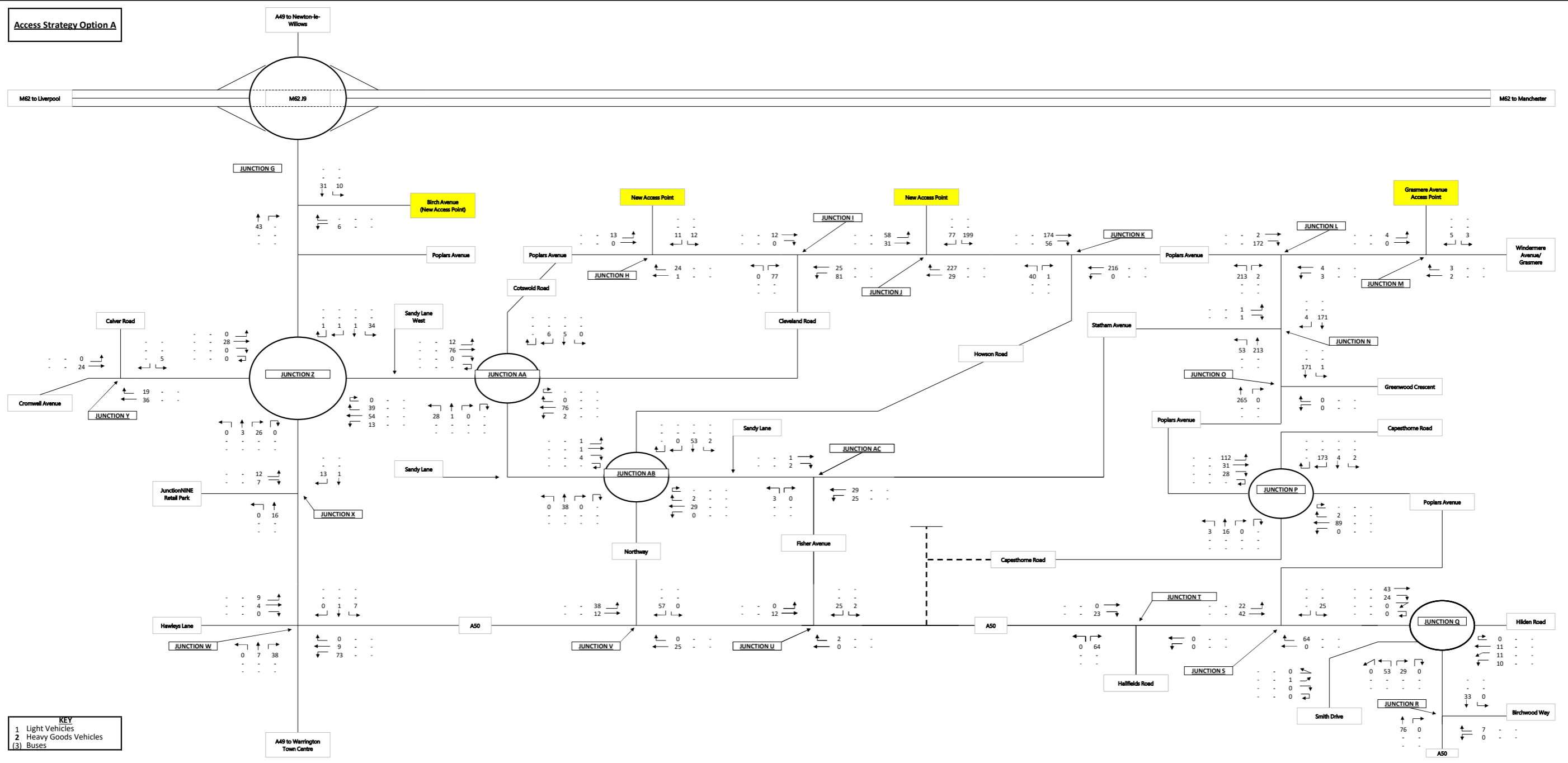

KEY

1	Light Vehicles
2	Heavy Goods Vehicles
3	Buses

PROPOSED DEVELOPMENT: Peel Hall, Warrington
PM Development

2027 - Do Something (SW of M62)

HighgateTransportation

Access Strategy Option A

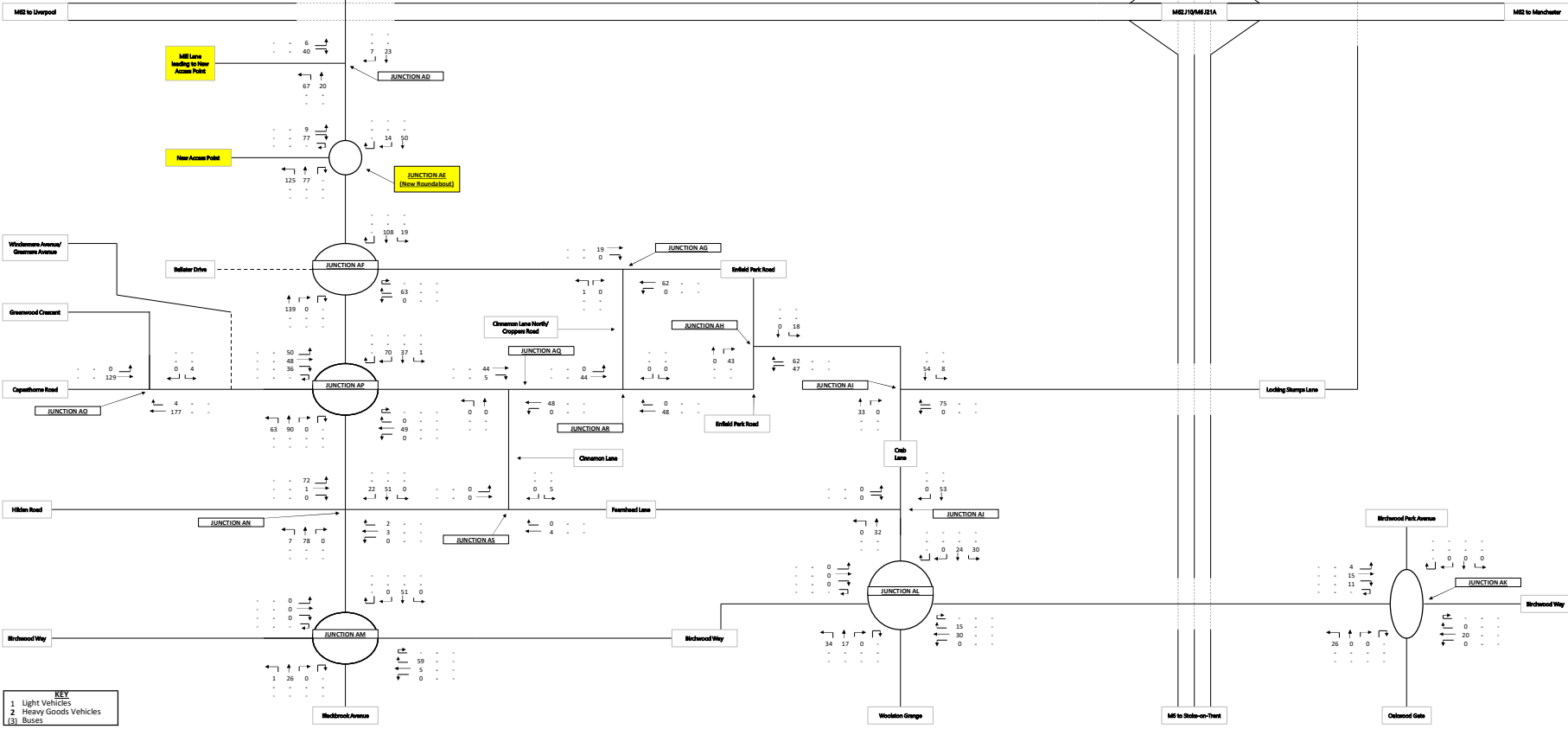

PROPOSED DEVELOPMENT: Peel Hall, Warrington
PM Development

2027 - Do Something (SE of M62)

Access Strategy Option A

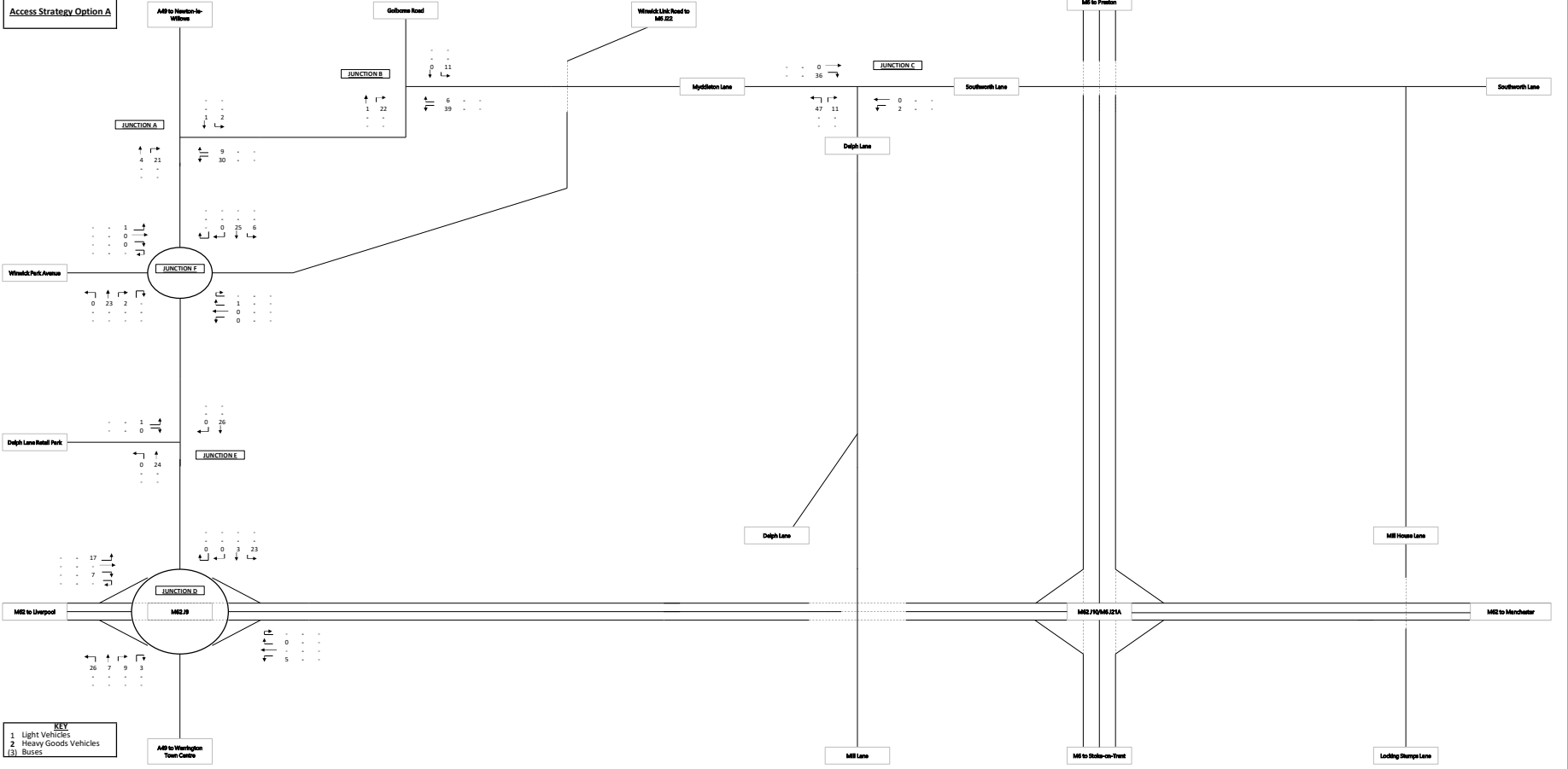

PROPOSED DEVELOPMENT: Peel Hall, Warrington
AM Development

Access Strategy Option A

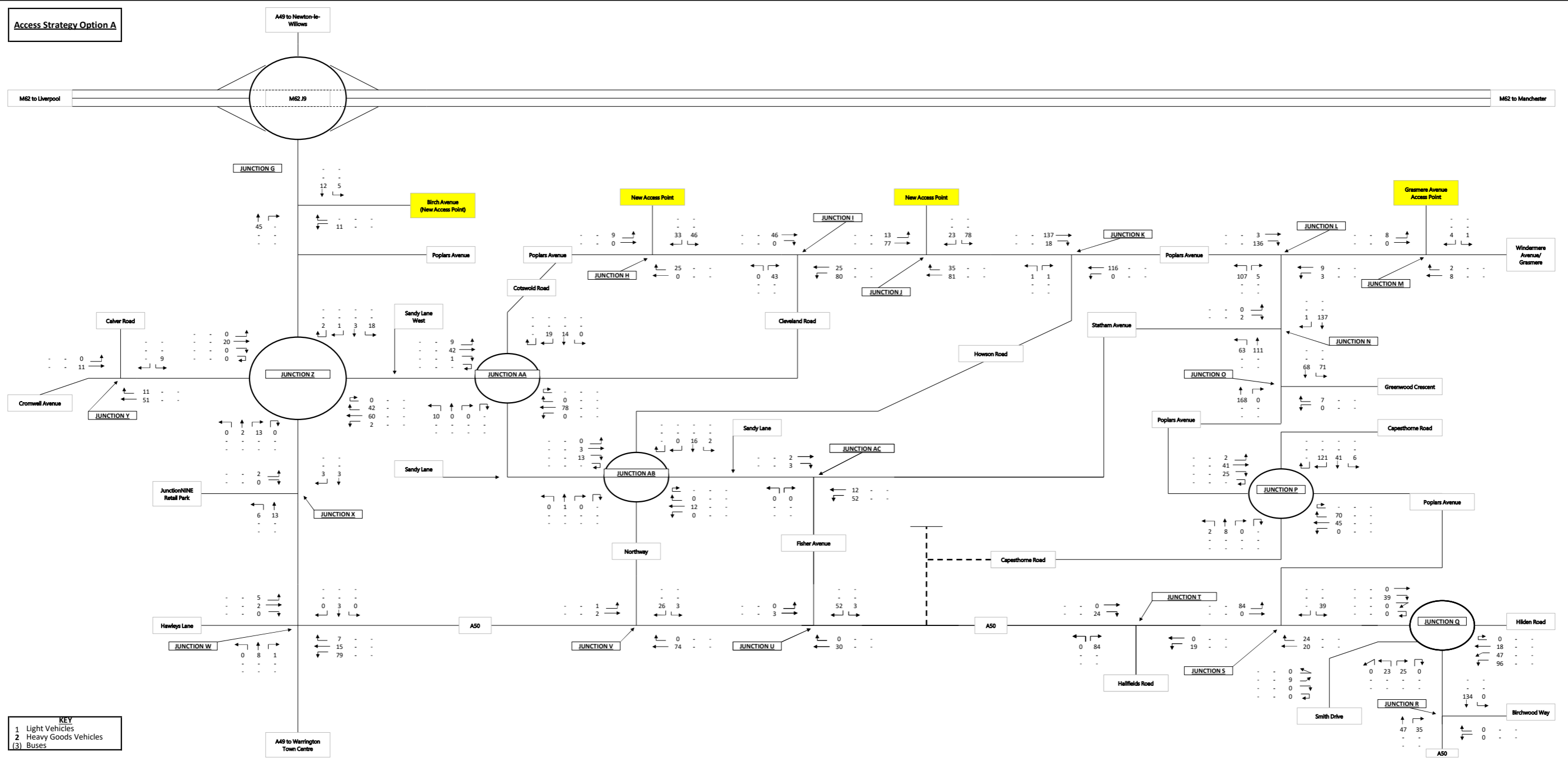

KEY
 1 Light Vehicles
 2 Heavy Goods Vehicles
 3 Buses

PROPOSED DEVELOPMENT: Peel Hall, Warrington
 AM Development

2032 - Do Something (FULL Development) (SW of M62)

HighgateTransportation

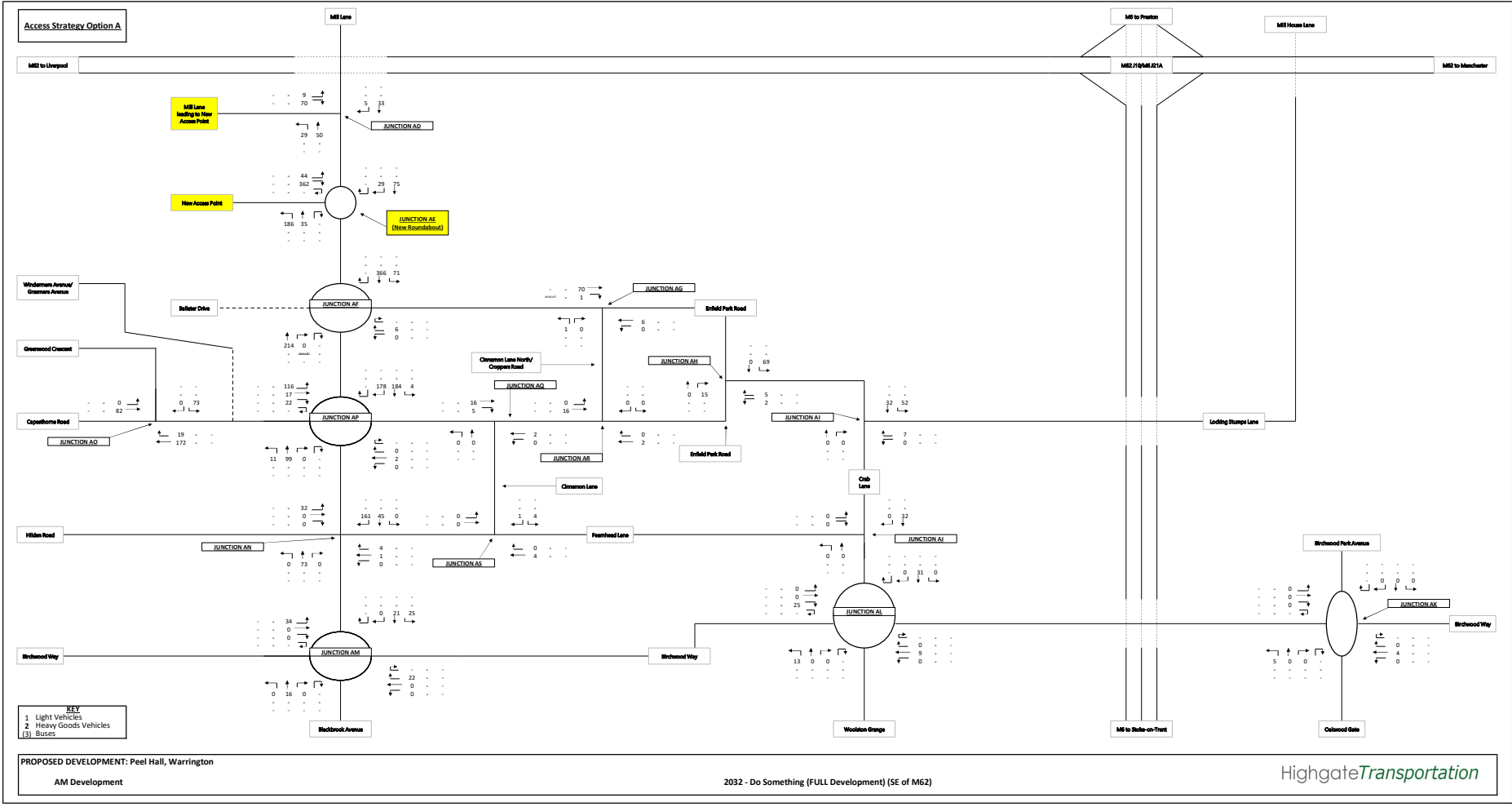

Access Strategy Option A

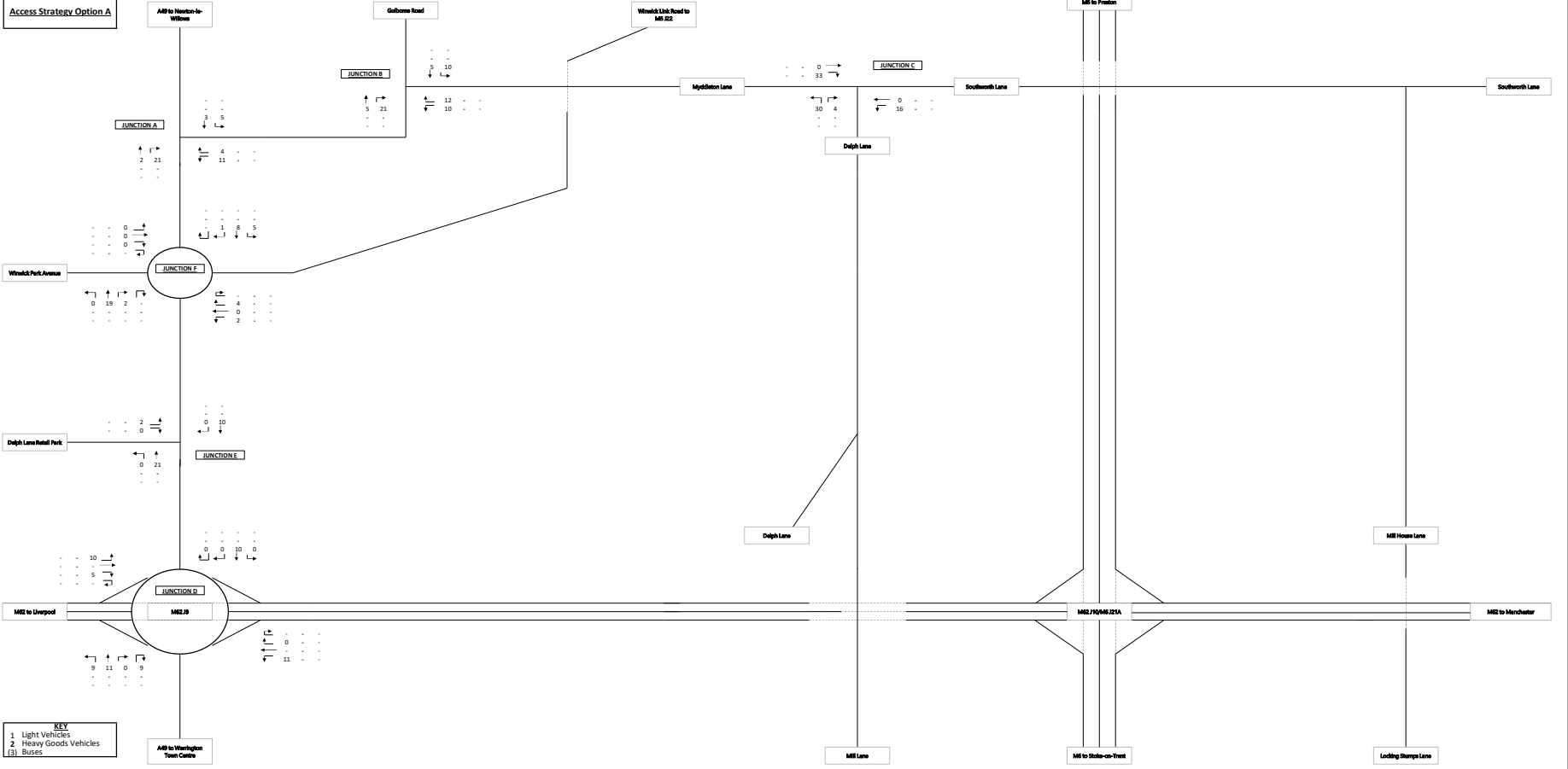

PROPOSED DEVELOPMENT: Peel Hall, Warrington
PM Development

Access Strategy Option A

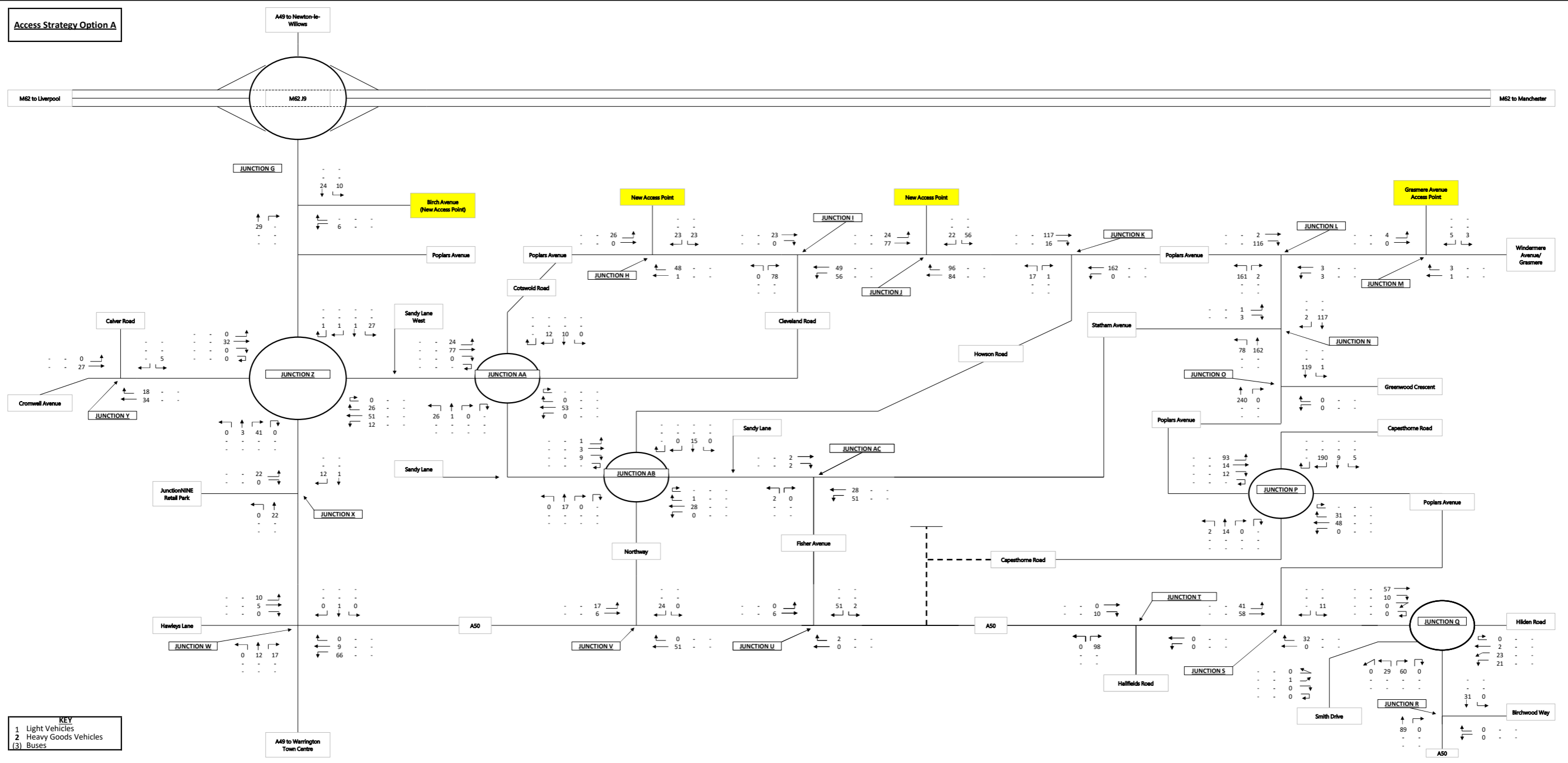

KEY

1	Light Vehicles
2	Heavy Goods Vehicles
3	Buses

PROPOSED DEVELOPMENT: Peel Hall, Warrington
PM Development

2032 - Do Something (FULL Development) (SW of M62)

HighgateTransportation

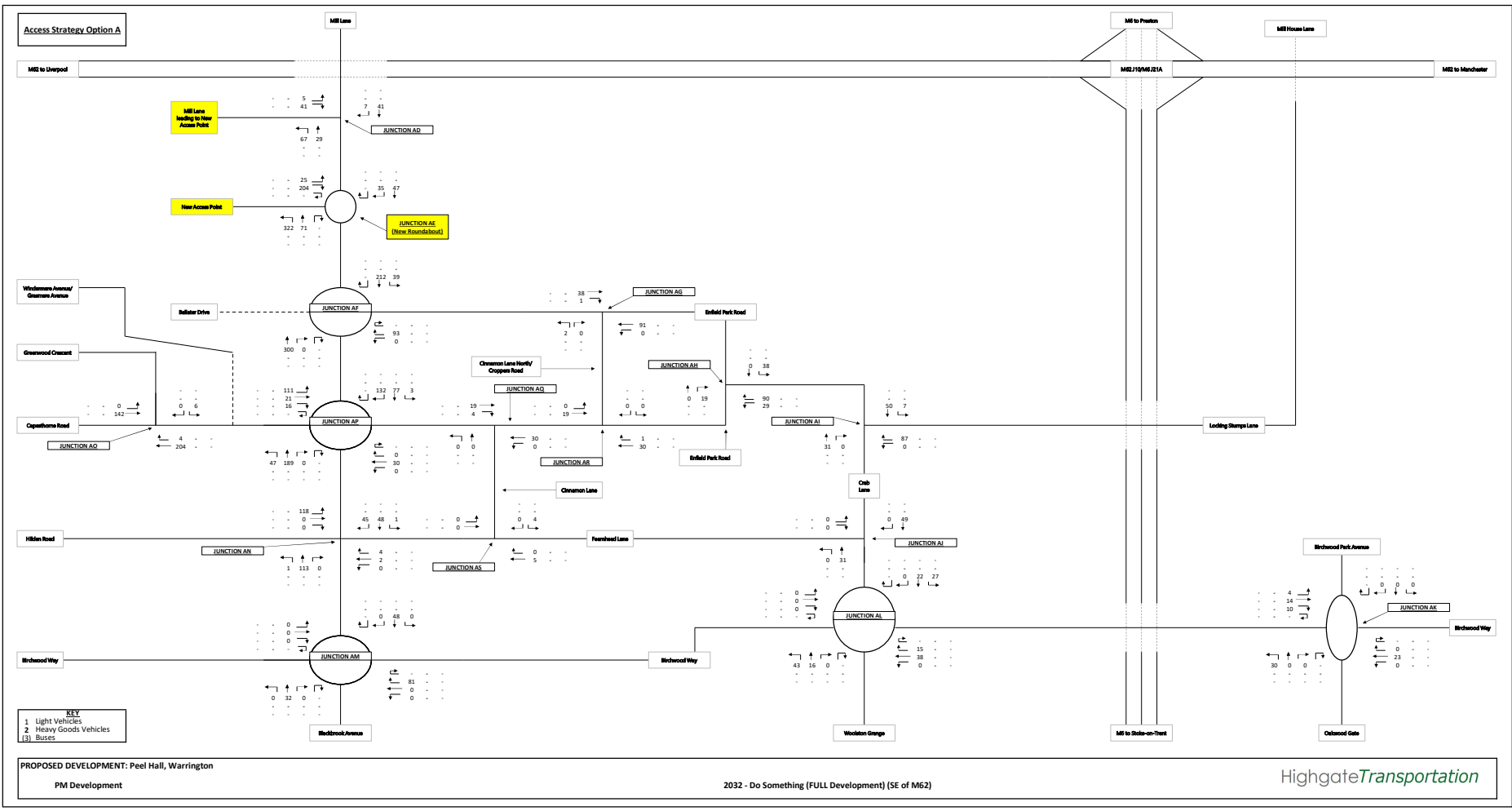

Subject: RE: Peel Hall - AADT and AAWT
Date: Wednesday, 13 November 2019 at 08:21:04 Greenwich Mean Time
From: Taylor, Mike
To: Fiona Bennett
CC: dave.tighe, Wright, Colin, Dickin, Alan
Attachments: image001.png, image002.png

Fiona,

As per my previous email apologies for the delay.

The conversion factors have been identified as directional whereas it may be simpler to provide a flow-weighted average for each area; for example modification of Table 1 would give:

A49	AM	PM	24AADT	AADT Fac	18AAWT	AAWT Fac
NB	1096	1662	20435	14.819	20712	15.020
SB	1718	1362	20583	13.366	21035	13.659
TOTAL	2814	3024	41018	14.052	41747	14.302

I would appreciate your consideration and comment on this point.

Regards

Mike

Mike Taylor

Transport Development Control Team Leader

Environment and Transport Directorate
Transport for Warrington
Warrington Borough Council
New Town House, Buttermarket Street, Warrington, WA1 2NH

 mike.taylor@warrington.gov.uk

 Office: 01925 444086 Mobile: 07966 884639

warrington.gov.uk

From: Fiona Bennett [mailto:fiona.bennett@highgatetransportation.co.uk]
Sent: 25 October 2019 15:05
To: Taylor, Mike <mike.taylor@warrington.gov.uk>
Cc: dave.tighe <dave.tighe@highgatetransportation.co.uk>; Wright, Colin <Colin.Wright@wsp.com>; Dickin, Alan <adickin@warrington.gov.uk>
Subject: Peel Hall - AADT and AAWT

Afternoon Mike,

Please find attached the updated TN/08 (Revision A). Hopefully this will clarify matters.

Happy to discuss.

Subject: Re: Peel Hall - AADT and AAWT
Date: Wednesday, 13 November 2019 at 09:19:44 Greenwich Mean Time
From: Fiona Bennett
To: Taylor, Mike
CC: dave.tighe, Wright, Colin, Dickin, Alan
Attachments: image001.png, image002.png

Good morning Mike,

We are happy to provide a flow-weighted average for each area as you suggest in your email below. This will certainly make it simpler for all parties going forwards.

We will update the tables from TN/08/A following the methodology you set out in your modified Table 1 below, email across for your records and proceed on this basis for the provision of data to feed into the Noise and Air Quality assessments.

We should be in a position to send across the analysed WMMTM16 data in spreadsheet and flow diagram format shortly. Hopefully we can then arrange a meeting to discuss the next steps in terms of impact, analysis and mitigation.

Kind regards,
Fiona

Fiona Bennett
Highgate *Transportation*
Tel: 0117 934 9121
Mob: 07595 892 217
fiona.bennett@highgatetransportation.co.uk

www.highgatetransportation.co.uk

*Highgate Transportation Ltd
First Floor, 43-45 Park Street
BRISTOL BS1 5NL
Company Registration Number: 07500534*

This message (including any attachments) is confidential and intended for the addressee only. The material in it may also be subject to copyright protection. If you are not the addressee you are notified that any use, review, disclosure, or copying of the information in it is prohibited. If you have received this message in error please notify us and delete any copies of it. Whilst we take sensible precautions we cannot guarantee that this message or any attachments are virus free.

Please consider the environment before printing this email and any attachments.

From: "Taylor, Mike" <mike.taylor@warrington.gov.uk>
Date: Wednesday, 13 November 2019 at 08:21
To: Fiona Bennett <fiona.bennett@highgatetransportation.co.uk>
Cc: "dave.tighe" <dave.tighe@highgatetransportation.co.uk>, "Wright, Colin" <Colin.Wright@wsp.com>, "Dickin, Alan" <adickin@warrington.gov.uk>
Subject: RE: Peel Hall - AADT and AAWT

Fiona,

As per my previous email apologies for the delay.

The conversion factors have been identified as directional whereas it may be simpler to provide a flow-weighted average for each area; for example modification of Table 1 would give:

Subject: Peel Hall - Traffic Flow Data - AADT and AAWT Factors
Date: Thursday, 21 November 2019 at 14:28:24 Greenwich Mean Time
From: Fiona Bennett
To: Taylor, Mike
CC: dave.tighe, Wright, Colin, Dickin, Alan
Attachments: image001.png, image002.png, image003.png

Dear Mike,

I am about to send via WeTransfer Peel Hall flow diagrams across all scenarios for Access Strategy A, the accompanying spreadsheets and original AECOM datasets. We will send across the same for Access Strategy B shortly, once finalised.

In terms of AADT/AAWT factors, we have updated the tables from TN/08/A further to your email of 13th November as follows:

Table 1 – A49 flows and conversion factors

	AM Flow	PM Flow	24-hour Flow	24-hour AADT scale factor	18-hour Flow	18-hour AAWT scale factor
7-Day						
Northbound A49**			20,435	14.817		
Southbound A49**			20,583	13.366		
5-Day						
Northbound A49**	1,096	1,662			20,712	15.017
Southbound A49**	1,718	1,362			21,035	13.660
Total	2,814*	3,024*	41,018*	14.052	41,747*	14.302

** Figures taken directly from Excel 8551 – A49 Winwick Road – ATC Survey Results_FB

* Sum of tabulated figures

Table 2 – A50 flows and conversion factors

	AM Flow	PM Flow	24-hour Flow	24-hour AADT scale factor	18-hour Flow	18-hour AAWT scale factor
7-Day						
Westbound A50*			7,707	10.939		
Eastbound A50*			7,308	11.805		
5-Day						
Westbound A50*	712	697			8,170	11.595
Eastbound A50*	594	644			7,822	12.634
Total (as above)	1,306	1,341	15,015	11.345	15,992	12.083

* Figures taken directly from Excel Warrington A50 ATC_FB

Table 3 – Poplars Avenue flows and conversion factors

	AM Flow	PM Flow	24-hour Flow	24-hour AADT scale factor	18-hour Flow	18-hour AAWT scale factor
7-Day						
Westbound Poplars*			2,808	11.847		
Eastbound Poplars*			2,970	10.347		
5-Day						
Westbound Poplars*	171	303			2,843	11.995
Eastbound Poplars*	330	244			3,102	10.808
Total (as above)	501	547	5,778	11.027	5,945	11.345

Figures taken directly from Excel Warrington Poplars Avenue ATC_FB

Table 4 – Blackbrook Avenue flows and conversion factors

	AM Flow	PM Flow	24-hour Flow	24-hour AADT scale factor	18-hour Flow	18-hour AAWT scale factor
7-Day						
Northbound Blackbrook*			2,867	9.882		
Southbound Blackbrook*			3,294	8.298		
5-Day						
Northbound Blackbrook*	245	335			3,054	10.527
Southbound Blackbrook*	496	298			3,622	9.123
Total (as above)	741	633	6,161	8.968	6,676	9.718

Figures taken directly from Excel Warrington ATC 1115_FB

Table 5 – Delph Lane flows and conversion factors

	AM Flow	PM Flow	24-hour Flow	24-hour AADT scale factor	18-hour Flow	18-hour AAWT scale factor
7-Day						
Northbound Delph*			3,373	8.125		
Southbound Delph*			3,636	8.480		
5-Day						
Northbound Delph*	351	480			3,663	8.822
Southbound Delph*	500	358			3,931	9.168
Total (as above)	851	838	7,009	8.300	7,594	8.992

Figures taken directly from Excel Warrington Delph Lane ATC_FB

$$\text{AADT FACTOR} * ((\text{SATURN AM} + \text{PM peak hour two-way flows}) / 2) = \text{AADT24}$$

$$\text{AAWT FACTOR} * ((\text{SATURN AM} + \text{PM peak hour two-way flows}) / 2) = \text{AAWT18}$$

Table 6 – Summary of conversion factors

24-hour AADT	18-hour AAWT
A49	
14.052	14.302
A50	
11.345	12.083
Poplars Avenue	
11.027	11.345
Blackbrook Avenue	
8.968	9.718
Delph Lane	
8.300	8.992

Figure 2 TN/08/A - Areas for factors to be used

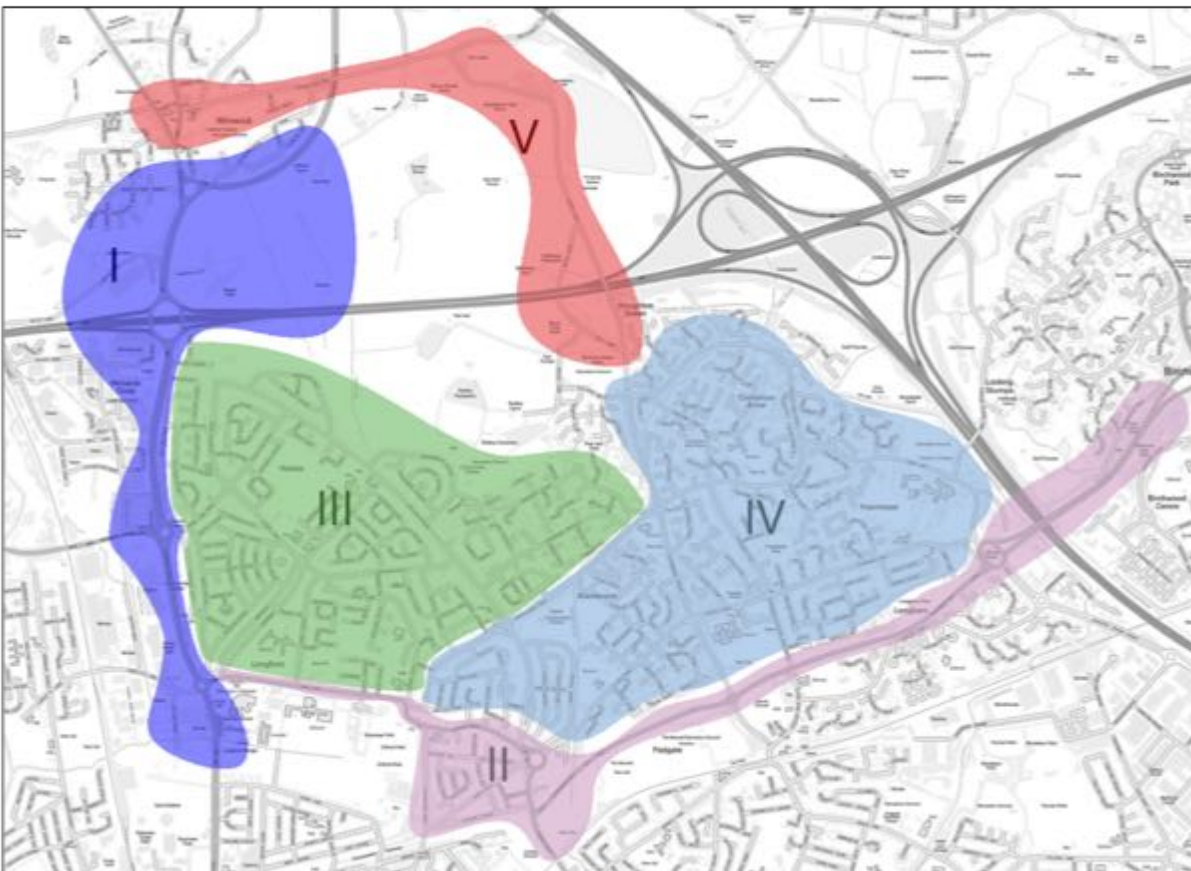

It would be good to have a meeting date in the diary for early December – please could you let us know your availability?

Kind regards,

Fiona

Fiona Bennett

Highgate *Transportation*

Tel: 0117 934 9121

Mob: 07595 892 217

fiona.bennett@highgatetransportation.co.uk

www.highgatetransportation.co.uk

Highgate Transportation Ltd

First Floor, 43-45 Park Street

BRISTOL BS1 5NL

Company Registration Number: 07500534

This message (including any attachments) is confidential and intended for the addressee only. The material in it may also be subject to copyright protection. If you are not the addressee you are notified that any use, review, disclosure, or copying of the information in it is prohibited. If you have received this message in error please notify us and delete any copies of it. Whilst we take sensible precautions we cannot guarantee that this message or any attachments are virus free.

Please consider the environment before printing this email and any attachments.

From: Fiona Bennett <fiona.bennett@highgatetransportation.co.uk>

Date: Wednesday, 13 November 2019 at 09:19

To: "Taylor, Mike" <mike.taylor@warrington.gov.uk>

Cc: "dave.tighe" <dave.tighe@highgatetransportation.co.uk>, "Wright, Colin" <Colin.Wright@wsp.com>, "Dickin, Alan" <adickin@warrington.gov.uk>

Subject: Re: Peel Hall - AADT and AAWT

Good morning Mike,

We are happy to provide a flow-weighted average for each area as you suggest in your email below. This will certainly make it simpler for all parties going forwards.

We will update the tables from TN/08/A following the methodology you set out in your modified Table 1 below, email across for your records and proceed on this basis for the provision of data to feed into the Noise and Air Quality assessments.

We should be in a position to send across the analysed WMMTM16 data in spreadsheet and flow diagram format shortly. Hopefully we can then arrange a meeting to discuss the next steps in terms of impact, analysis and mitigation.

Kind regards,

Fiona

Fiona Bennett

Highgate *Transportation*

Subject: Peel Hall - M62 AAWT and AADT Factors
Date: Monday, 25 November 2019 at 12:54:56 Greenwich Mean Time
From: Fiona Bennett
To: Laverick, Benjamin
CC: Gavin.Coupe@atkinsglobal.com, Dave Tighe (dave.tighe@highgatetransportation.co.uk)
Attachments: image001.png

Afternoon Ben,

Do you have appropriate AADT and 18-hour AAWT factors for the M62 mainline around Junction 9 that we can provide to the Air Quality and Noise teams for factoring up the AM+PM peak hour SATURN flows to corresponding Annual Average Daily Traffic and Annual Average Weekday Traffic?

We have the following factors for the A49:

24-hour AADT	18-hour AAWT
A49	
14.052	14.302

$$\text{AADT FACTOR} * ((\text{SATURN AM+PM peak hour two-way flows}) / 2) = \text{AADT24}$$

$$\text{AAWT FACTOR} * ((\text{SATURN AM+PM peak hour two-way flows}) / 2) = \text{AAWT18}$$

Happy to discuss.

Kind regards,
Fiona

Fiona Bennett
Highgate Transportation
Tel: 0117 934 9121
Mob: 07595 892 217
fiona.bennett@highgatetransportation.co.uk

www.highgatetransportation.co.uk

*Highgate Transportation Ltd
First Floor, 43-45 Park Street
BRISTOL BS1 5NL
Company Registration Number: 07500534*

This message (including any attachments) is confidential and intended for the addressee only. The material in it may also be subject to copyright protection. If you are not the addressee you are notified that any use, review, disclosure, or copying of the information in it is prohibited. If you have received this message in error please notify us and delete any copies of it. Whilst we take sensible precautions we cannot guarantee that this message or any attachments are virus free.

Please consider the environment before printing this email and any attachments.

Subject: Peel Hall - M62 AAWT and AADT Factors
Date: Tuesday, 26 November 2019 at 12:36:54 Greenwich Mean Time
From: Fiona Bennett
To: Laverick, Benjamin
CC: dave.tighe, Gavin.Coupe@atkinsglobal.com
Attachments: image001.png

Afternoon Ben,

Further to my email yesterday (below) where I asked if you were happy for us to use the factors provided for the A49 (using 2018 ATC data) to be applied to the M62 mainline future flows for obtaining AADT and AAWT from the AM and PM peak hour flows from the AECOM SATURN data, we have reviewed the AADT24 and AAWT18 2018 Do Minimum flow summaries from the mainline data provided by AECOM (WMMTM16 for Peel Hall) and this is summarised as:

Total two-way average daily traffic of 121,100 (PCU) *(as provided by AECOM)*

Total two-way AM flows of 9,634 (PCU) *(as provided in the dataset)*

Total two-way PM flows of 10,399 (PCU) *(as provided in the dataset)*

Approximate AADT24 M62 mainline Factor of 12.090

Total two-way average weekday traffic of 126,790 (PCU) *(as provided by AECOM)*

Total two-way AM flows of 9,634 (PCU) *(as provided in the dataset)*

Total two-way PM flows of 10,399 (PCU) *(as provided in the dataset)*

Approximate AAWT18 M62 mainline Factor of 12.658

We will move forward on the basis of the M62 mainline factors as set out above unless we hear otherwise today.

Happy to discuss.

Kind regards,
Fiona

Fiona Bennett

Highgate *Transportation*

Tel: 0117 934 9121

Mob: 07595 892 217

fiona.bennett@highgatetransportation.co.uk

www.highgatetransportation.co.uk

Highgate Transportation Ltd

First Floor, 43-45 Park Street

BRISTOL BS1 5NL

Company Registration Number: 07500534

This message (including any attachments) is confidential and intended for the addressee only. The material in it may also be subject to copyright protection. If you are not the addressee you are notified that any use, review, disclosure, or copying of the information in it is prohibited. If you have received this message in error please notify us and delete any copies of it. Whilst we take sensible precautions we cannot guarantee that this message or any attachments are virus free.

Please consider the environment before printing this email and any attachments.

From: Fiona Bennett <fiona.bennett@highgatetransportation.co.uk>

Date: Monday, 25 November 2019 at 12:54

To: "Laverick, Benjamin" <Benjamin.Laverick@highwaysengland.co.uk>

Cc: "Gavin.Coupe@atkinsglobal.com" <Gavin.Coupe@atkinsglobal.com>, "Dave Tighe"

Subject: RE: Peel Hall - M62 AAWT and AADT Factors
Date: Tuesday, 26 November 2019 at 14:03:10 Greenwich Mean Time
From: Laverick, Benjamin
To: Fiona Bennett
CC: dave.tighe
Attachments: image002.png

Hi Fiona,

I am content with the proposed factors as laid out below.

Kind regards

Ben

Benjamin Laverick, Assistant Asset Manager

Highways England | Piccadilly Gate | Store Street | Manchester | M1 2WD

Web: www.highwaysengland.co.uk

From: Fiona Bennett [mailto:fiona.bennett@highgatetransportation.co.uk]
Sent: 26 November 2019 12:37
To: Laverick, Benjamin <Benjamin.Laverick@highwaysengland.co.uk>
Cc: dave.tighe <dave.tighe@highgatetransportation.co.uk>; Gavin.Coupe@atkinglobal.com
Subject: Peel Hall - M62 AAWT and AADT Factors

Afternoon Ben,

Further to my email yesterday (below) where I asked if you were happy for us to use the factors provided for the A49 (using 2018 ATC data) to be applied to the M62 mainline future flows for obtaining AADT and AAWT from the AM and PM peak hour flows from the AECOM SATURN data, we have reviewed the AADT24 and AAWT18 2018 Do Minimum flow summaries from the mainline data provided by AECOM (WMMTM16 for Peel Hall) and this is summarised as:

Total two-way average daily traffic of 121,100 (PCU) *(as provided by AECOM)*
Total two-way AM flows of 9,634 (PCU) *(as provided in the dataset)*
Total two-way PM flows of 10,399 (PCU) *(as provided in the dataset)*
Approximate AADT24 M62 mainline Factor of 12.090

Total two-way average weekday traffic of 126,790 (PCU) *(as provided by AECOM)*
Total two-way AM flows of 9,634 (PCU) *(as provided in the dataset)*
Total two-way PM flows of 10,399 (PCU) *(as provided in the dataset)*
Approximate AAWT18 M62 mainline Factor of 12.658

We will move forward on the basis of the M62 mainline factors as set out above unless we hear otherwise today.

Happy to discuss.

Kind regards,
Fiona

Fiona Bennett
Highgate *Transportation*

Tel: 0117 934 9121
Mob: 07595 892 217

TECHNICAL NOTE

PROJECT: Peel Hall, Warrington

REPORT: 1901/TN/08/A – Conversion factors for 24-Hour AADT & 18-Hour AAWT

DATE: August 2019 (updated September 2019)

1. This Technical Note has been provided to set out the calculation factors for taking the Peel Hall WMMTM16 SATURN model AM and PM peak hour outputs and converting to 24-hour AADT¹ and 18-hour AAWT² (0600-2400 hours). This is for the purposes of the Air Quality and Noise Assessments required to support the development of land at Peel Hall, Warrington.
2. The factors are being determined from existing week-long ATC traffic count data from the following roads and the locations of these surveys are indicated on **Figure 1**.
 - i. A49 (2018)
 - ii. A50 (2019)
 - iii. Poplars Avenue (2019)
 - iv. Blackbrook Avenue (2015)
 - v. Delph Lane (2019)

Figure 1 – ATC Location Plan

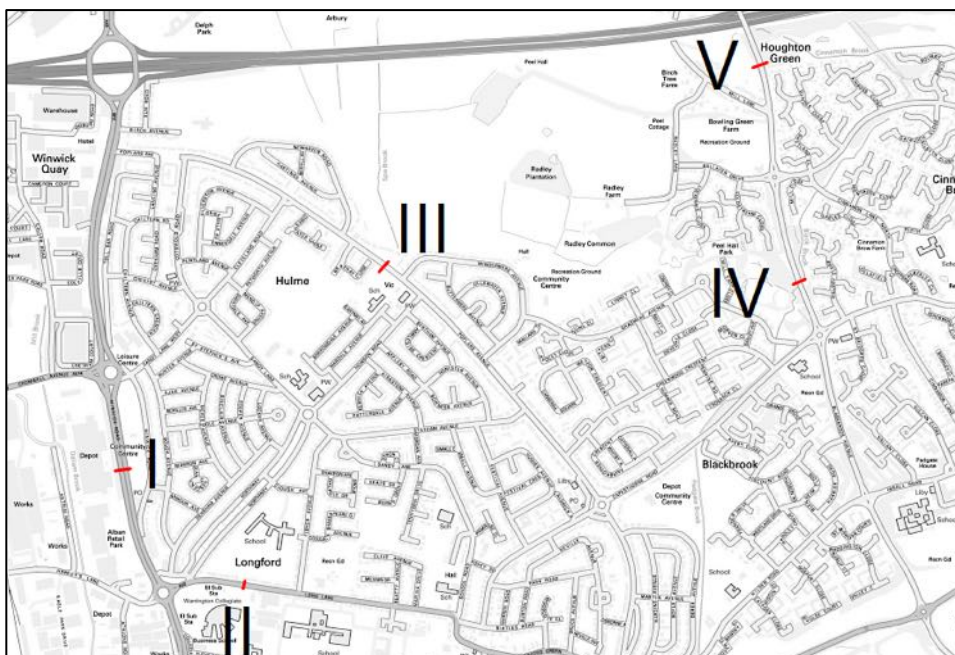

¹ Average Annual Daily Traffic (7-day)

² Average Annual Weekday traffic (5-day)

3. The AM (0800-0900) and PM (1700-1800) two-way weekday flows from the ATC data is provided with the 24-hour weekly data and 18-hour weekday for each site in turn below.
4. The resultant 24-hour AADT and 18-hour AAWT are then presented for agreement with Warrington Borough Council (WBC), using the 5-day average peak hour flows as these are what will be available from the SATURN outputs.

A49 – Traffic Data

5. Traffic surveys were undertaken along the A49 between the Sandy Lane West signalised roundabout and the Junction 9 Retail Park three-arm signal junction to the south. The survey was undertaken between Tuesday 20th March 2018 and Monday 2nd April 2018. Easter was Sunday 1st April in 2018, and the Warrington school holidays ran from Saturday 6th to Monday 22nd April that year. Therefore, the first week of this data has been used (20th to 26th March 2018).
6. The resultant summary data and conversion factors are provided in **Table 1**.

Table 1 – A49 flows and conversion factors

	AM Flow	PM Flow	24-hour Flow	18-hour Flow	24-hour AADT scale factor	18-hour AAWT scale factor
7-Day						
Northbound A49			20,435		14.817	
Southbound A49			20,583		13.366	
5-Day						
Northbound A49	1,096	1,662		20,712		15.017
Southbound A49	1,718	1,362		21,035		13.660

7. The ATC data is provided in **Appendix 1** for reference alongside the data analysis.
8. As set out at **Table 1**, the conversion factors to forecast 24-hour AADT using the peak hour flows from the SATURN model for the A49 corridor is 14.817 and 13.336 for northbound and southbound flows respectively.
9. The corresponding factors for forecasting 18-hour AAWT using the peak hour flows from the SATURN model for the A49 corridor is 15.017 and 13.660 for northbound and southbound flows respectively.
10. Therefore, these factors would be used as follows:

$$\text{AADT DIRECTIONAL FACTOR} * ((\text{AM} + \text{PM peak hour directional flows}) / 2) = \text{AADT}_{24}$$

$$\text{AAWT DIRECTIONAL FACTOR} * ((\text{AM} + \text{PM peak hour directional flows}) / 2) = \text{AAWT}_{18}$$

A50 – Traffic Data

11. Traffic surveys were undertaken along the A50. The survey was undertaken between Saturday 30th March 2019 and Friday 5th April 2019. Easter was Sunday 21st April in 2019, and the Warrington school holidays ran from either Saturday 6th or Saturday 13th to Tuesday 23rd or Monday 29th April that year.
12. The resultant summary data and conversion factors are provided in **Table 2**.

Table 2 – A50 flows and conversion factors

	AM Flow	PM Flow	24-hour Flow	18-hour Flow	24-hour AADT scale factor	18-hour AAWT scale factor
7-Day						
Westbound A50			7,707		10.939	
Eastbound A50			7,308		11.805	
5-Day						
Westbound A50	712	697		8,170		11.595
Eastbound A50	594	644		7,822		12.634

13. The ATC data is provided in **Appendix 2** for reference alongside the data analysis.
14. As set out at **Table 2**, the conversion factors to forecast 24-hour AADT using the peak hour flows from the SATURN model for the A50 corridor is 10.939 and 11.805 for westbound and eastbound flows respectively.
15. The corresponding factors for forecasting 18-hour AAWT using the peak hour flows from the SATURN model for the A50 corridor is 11.595 and 12.634 for westbound and eastbound flows respectively.
16. These factors would be applied as set out in **paragraph 10**.

Poplars Avenue – Traffic Data

17. Traffic surveys were undertaken at three locations along Poplars Avenue in March/April 2019. For the purposes of this assessment the busiest of the three locations has been used. This survey location was between the Poplars Avenue junctions with Newhaven Road and Windermere Avenue. The survey was undertaken between Saturday 30th March 2019 and Friday 5th April 2019.
18. The resultant summary data and conversion factors are provided in **Table 3**.

Table 3 – Poplars Avenue flows and conversion factors

	AM Flow	PM Flow	24-hour Flow	18-hour Flow	24-hour AADT scale factor	18-hour AAWT scale factor
7-Day						
Westbound Poplars			2,808		11.847	
Eastbound Poplars			2,970		10.347	
5-Day						
Westbound Poplars	171	303		2,843		11.995
Eastbound Poplars	330	244		3,102		10.808

19. The ATC data is provided in **Appendix 3** for reference alongside the data analysis.
20. As set out at **Table 3**, the conversion factors to forecast 24-hour AADT using the peak hour flows from the SATURN model for the Poplars Avenue area is 11.847 and 10.347 for westbound and eastbound flows respectively.
21. The corresponding factors for forecasting 18-hour AAWT using the peak hour flows from the SATURN model for the Poplars Avenue area is 11.995 and 10.808 for westbound and eastbound flows respectively.
22. These factors would be applied as set out in **paragraph 10**.

Blackbrook Avenue – Traffic Data

23. Traffic surveys were undertaken along Blackbrook Avenue adjacent to Peel Hall Park. The survey was undertaken between Friday 20th and Thursday 26th November 2015.
24. The resultant summary data and conversion factors are provided in **Table 4**.

Table 4 – Blackbrook Avenue flows and conversion factors

	AM Flow	PM Flow	24-hour Flow	18-hour Flow	24-hour AADT scale factor	18-hour AAWT scale factor
7-Day						
Northbound Blackbrook			2,867		9.882	
Southbound Blackbrook			3,294		8.298	
5-Day						
Northbound Blackbrook	245	335		3,054		10.527
Southbound Blackbrook	496	298		3,622		9.123

25. The ATC data is provided in **Appendix 4** for reference alongside the data analysis.

- 26. As set out at **Table 4**, the conversion factors to forecast 24-hour AADT using the peak hour flows from the SATURN model for the Blackbrook Avenue area is 9.882 and 8.298 for northbound and southbound flows respectively.
- 27. The corresponding factors for forecasting 18-hour AAWT using the peak hour flows from the SATURN model for the Blackbrook Avenue area is 10.527 and 9.123 for northbound and southbound flows respectively.
- 28. These factors would be applied as set out in **paragraph 10**.

Delph Lane – Traffic Data

- 29. Additional traffic surveys were undertaken along Delph Lane, effectively a continuation to the north of Blackbrook Avenue and the data reviewed against the older 2015 data. The survey was undertaken between Saturday 30th March 2019 and Friday 5th April 2019.
- 30. The resultant summary data and conversion factors are provided in **Table 5**.

Table 5 – Delph Lane flows and conversion factors

	AM Flow	PM Flow	24-hour Flow	18-hour Flow	24-hour AADT scale factor	18-hour AAWT scale factor
7-Day						
Northbound Delph			3,373		8.125	
Southbound Delph			3,636		8.480	
5-Day						
Northbound Delph	351	480		3,663		8.822
Southbound Delph	500	358		3,931		9.168

- 31. The ATC data is provided in **Appendix 5** for reference alongside the data analysis.
- 32. As set out at **Table 5**, the conversion factor to forecast 24-hour AADT using the peak hour flows from the SATURN model for the Delph Lane area is 8.125 and 8.480 for northbound and southbound flows respectively.
- 33. The corresponding factors for forecasting 18-hour AAWT using the peak hour flows from the SATURN model for the Delph Lane area is 8.822 and 9.126 for northbound and southbound flows respectively.
- 34. Given the 2019 data is more recent, it is considered that the factors from the Delph Lane data will be used to the areas north of the M62.
- 35. These factors would be applied as set out in **paragraph 10**.

Summary

- 36. This Technical Note has been provided to set out the calculation factors for taking the Peel Hall WMMTM16 SATURN model AM and PM peak hour outputs and converting to 24-hour AADT and 18-hour AAWT for the purposes of the Air Quality and Noise Assessments required to support the development of land at Peel Hall, Warrington.

37. The factors for 24-hour AADT and 18-hour AAWT flows are summarised at **Table 6**, with the corresponding links that these factors will be used for illustrated on **Figure 2**.

Table 6 – Summary of conversion factors

	24-hour AADT	18-hour AAWT
A49		
Northbound	14.817	15.017
Southbound	13.366	13.660
A50		
Westbound	10.939	11.595
Eastbound	11.805	12.634
Poplars Avenue		
Westbound	11.847	11.995
Eastbound	10.347	10.808
Blackbrook Avenue		
Northbound	9.882	10.527
Southbound	8.298	9.123
Delph Lane		
Northbound	8.125	8.822
Southbound	8.480	9.168

Figure 2 - Areas for factors to be used

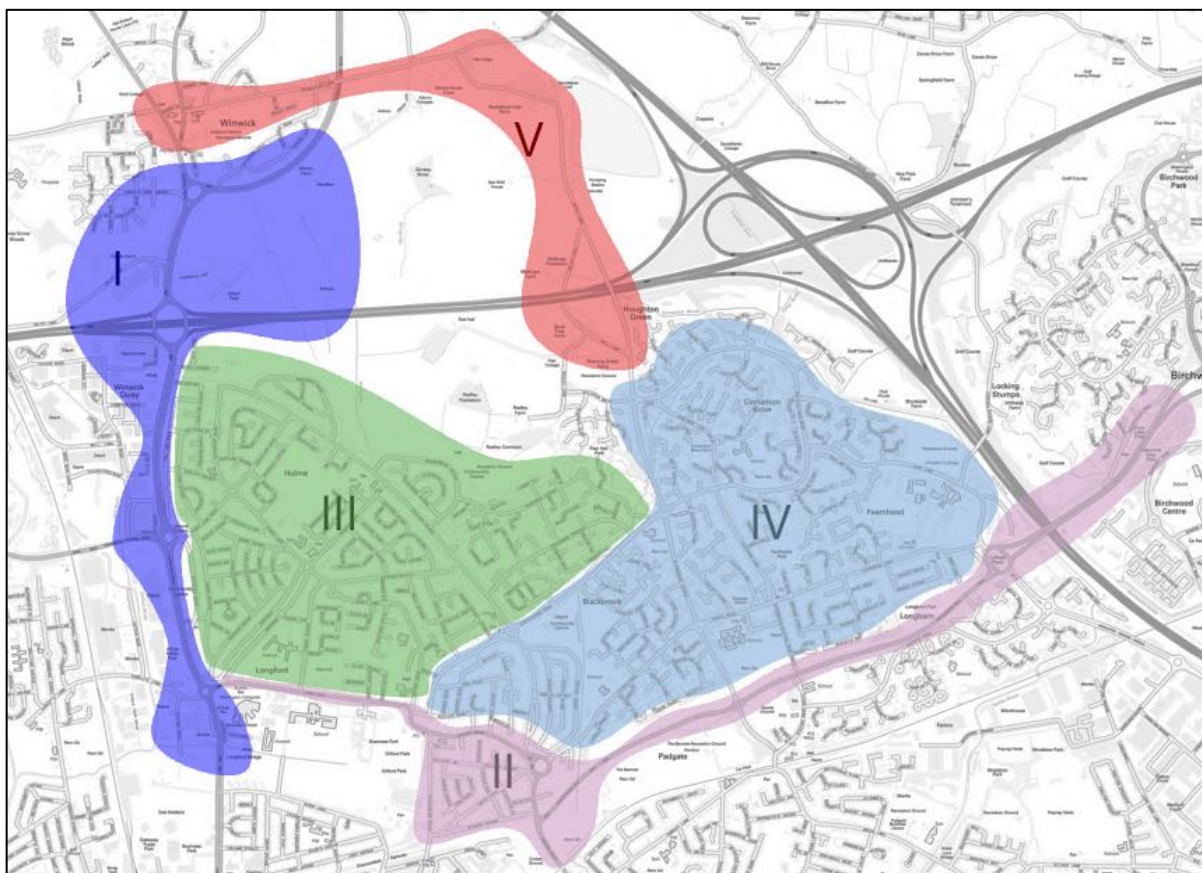

Appendix 1

ATC Data – A49

Tuesday 20 March 2018

Time	Total	Classification												JPSL	JPSL%	JSL1	JSL1%	JSL2	JSL2%	Mean	Vpp
		1	2	3	4	5	6	7	8	9	10	11	12								
	MCL	SV	SVT	TB2	TB3	T4	ART3	ART4	ART5	ART6	BD	DRT	40	ACPO	ACPO	DFT	DFT				
0000	0	69	0	9	1	1	0	8	12	4	0	0	23	5	4.8	0	0	36.9	41.2		
0100	0	43	0	14	2	0	0	2	13	1	0	0	19	3	4	0	0	36.8	42.3		
0200	0	29	0	14	0	0	0	1	6	7	0	1	11	4	6.9	0	0	35.7	40.9		
0300	0	50	0	16	0	0	0	2	3	2	0	0	26	8	11	0	0	38.5	43.6		
0400	2	60	0	24	0	0	0	0	7	5	0	0	32	5	5.1	1	1	37.3	43.6		
0500	1	291	2	50	1	2	0	7	4	9	1	0	98	18	4.9	2	0.5	37.5	42.3		
0600	8	454	9	75	9	5	1	16	7	11	0	1	157	30	5	2	0.3	37.2	42.3		
0700	8	881	16	112	18	6	5	32	8	12	0	5	118	14	1.3	1	0.1	32.2	38.7		
0800	5	861	22	110	13	10	2	26	9	10	3	3	43	8	0.7	0	0	30.3	35.3		
0900	6	868	17	111	15	10	4	26	16	11	3	7	44	3	0.3	1	0.1	30.2	35.1		
1000	4	931	15	137	7	16	3	23	10	7	1	3	35	3	0.3	0	0	29.1	34.9		
1100	6	1077	20	116	18	4	2	21	11	15	1	3	30	5	0.4	0	0	28.4	34		
1200	8	1135	18	114	17	11	6	23	10	12	3	5	28	3	0.2	0	0	27.1	32.7		
1300	10	1265	22	88	8	14	3	28	10	7	3	7	32	2	0.1	0	0	28.9	34		
1400	12	1358	27	121	14	14	2	28	9	10	1	5	26	1	0.1	0	0	26.1	32.9		
1500	11	1420	38	98	7	7	4	40	12	12	5	3	13	1	0.1	0	0	26.1	33.1		
1600	19	1612	45	71	25	17	3	36	5	16	5	6	4	0	0	0	0	20.6	28.4		
1700	8	1572	54	44	16	10	1	62	2	13	4	9	15	1	0.1	1	0.1	22.9	30.9		
1800	4	1295	32	45	7	3	2	37	5	14	1	3	39	5	0.3	0	0	29.7	34.9		
1900	4	975	20	39	4	3	2	25	10	6	1	3	36	5	0.5	0	0	30.1	34.7		
2000	2	790	12	31	3	3	0	21	13	7	0	4	54	14	1.6	3	0.3	32.2	37.4		
2100	1	543	8	27	3	2	0	7	12	4	0	0	51	14	2.3	1	0.2	33.1	37.4		
2200	4	298	4	15	0	0	1	3	12	6	0	0	66	12	3.5	1	0.3	35	41.2		
2300	3	154	0	15	1	0	0	4	20	1	0	0	49	14	7.1	1	0.5	37.3	41.6		
07-19	101	14275	326	1167	165	122	37	382	107	139	30	59	427	46	0.3	3	0	27.1	34		
06-22	116	17037	375	1339	184	135	40	451	149	167	31	67	725	109	0.5	9	0	28	34.9		
06-00	123	17489	379	1369	185	135	41	458	181	174	31	67	840	135	0.7	11	0.1	28.2	35.1		
00-00	126	18031	381	1496	189	138	41	478	226	202	32	68	1049	178	0.8	14	0.1	28.5	35.6		



1
A49 Winwick Road -N53.412624, W2.597562
Northbound
Wednesday 21 March 2018

Site
Location
Direction

Time	Total	Classification												JPSL 40	JPSL% 40	JSL1 46 ACPO	JSL1% 46 ACPO	JSL2 55 DFT	JSL2% 55 DFT	Mean	Vpp 85
		1 MCL	2 SV	3 SVT	4 TB2	5 TB3	6 T4	7 ART3	8 ART4	9 ART5	10 ART6	11 BD	12 DRT								
0000	123	0	90	1	9	0	0	1	9	11	2	0	0	28	22.8	4	3.3	1	0.8	36.6	40.9
0100	70	0	39	1	14	1	0	0	1	10	4	0	0	17	24.3	5	7.1	0	0	36.9	41.2
0200	69	1	43	0	10	1	0	0	2	7	5	0	0	17	24.6	5	7.2	0	0	37.6	41.6
0300	63	0	41	0	13	1	0	0	0	6	2	0	0	18	28.6	5	7.9	1	1.6	38.4	43.8
0400	96	1	56	0	24	0	0	0	4	5	6	0	0	27	28.1	13	13.5	0	0	38.2	45.2
0500	356	3	296	4	33	2	3	0	6	4	5	0	0	119	33.4	27	7.6	3	0.8	38.4	43.2
0600	575	5	441	7	75	6	11	1	10	6	11	0	2	157	27.3	40	7	5	0.9	37.8	42.5
0700	1149	6	913	17	125	13	11	2	32	10	11	2	7	108	9.4	17	1.5	4	0.3	32.3	38.5
0800	1085	6	846	22	130	12	14	3	28	11	10	0	3	56	5.2	6	0.6	0	0	30.6	36.2
0900	1107	3	881	26	119	7	8	4	28	10	16	2	3	39	3.5	2	0.2	0	0	29.1	35.1
1000	1153	3	936	24	120	13	8	4	23	7	12	3	0	47	4.1	9	0.8	2	0.2	30.2	35.1
1100	1287	6	1100	14	93	5	5	2	41	6	8	1	6	28	2.2	6	0.5	1	0.1	29.2	34.4
1200	1324	6	1112	12	121	8	10	2	27	11	10	1	4	40	3	6	0.5	1	0.1	27.5	34.2
1300	1466	6	1225	36	105	13	16	1	37	7	16	3	1	36	2.5	2	0.1	0	0	29	34
1400	1701	7	1462	19	131	21	11	10	22	5	6	5	2	11	0.6	2	0.1	1	0.1	22.1	30.9
1500	1662	5	1427	41	100	21	5	3	36	4	11	3	6	16	1	2	0.1	0	0	25.5	32.2
1600	1760	12	1507	50	72	23	14	4	46	6	18	3	5	9	0.5	4	0.2	0	0	23.1	30.4
1700	1460	9	1259	55	28	21	14	6	44	3	10	5	6	3	0.2	0	0	0	0	12.4	16.6
1800	1496	4	1325	39	28	16	9	4	49	4	12	3	3	6	0.4	0	0	0	0	18.1	28
1900	1091	5	980	18	40	4	2	1	23	10	5	1	2	23	2.1	6	0.5	1	0.1	29.4	33.6
2000	892	4	801	17	20	2	0	0	25	9	10	1	3	49	5.5	10	1.1	1	0.1	31.2	36.5
2100	646	5	576	8	24	2	3	0	12	14	1	0	1	71	11	17	2.6	1	0.2	33.7	38.7
2200	409	3	382	2	13	1	0	0	2	4	2	0	0	75	18.3	20	4.9	5	1.2	35.7	40.3
2300	217	1	167	0	19	3	0	0	3	20	3	0	1	49	22.6	13	6	5	2.3	37.1	40.9
07-19	16650	73	13993	355	1172	173	125	45	413	84	140	31	46	399	2.4	56	0.3	9	0.1	25.2	33.6
06-22	19854	92	16791	405	1331	187	141	47	483	123	167	33	54	699	3.5	129	0.6	17	0.1	26.3	34.7
06-00	20480	96	17340	407	1363	191	141	47	488	147	172	33	55	823	4	162	0.8	27	0.1	26.6	34.9
00-00	21257	101	17905	413	1466	196	144	48	510	190	196	33	55	1049	4.9	221	1	32	0.2	27.1	35.6



Thursday 22 March 2018

Time	Total	Classification												JPSL	JPSL%	JSL1	JSL1%	JSL2	JSL2%	Mean	Vpp
		1	2	3	4	5	6	7	8	9	10	11	12								
	MCL	SV	SVT	TB2	TB3	T4	ART3	ART4	ART5	ART6	BD	DRT	40	ACPO	ACPO	DFT					
0000	105	1	75	0	8	0	0	6	11	4	0	0	28	7	6.7	1	37.1	42.7			
0100	69	0	40	0	13	0	0	2	10	4	0	0	14	5	7.2	2	36.5	40.9			
0200	70	1	46	0	14	0	0	2	6	1	0	0	26	7	10	2	39	44.7			
0300	67	0	40	1	12	0	0	2	8	4	0	0	21	6	9	1	38.3	43.8			
0400	102	2	67	1	26	0	0	0	5	1	0	0	29	11	10.8	1	37.3	43.2			
0500	383	3	313	2	44	3	2	4	6	6	0	0	112	26	6.8	2	37.7	42.3			
0600	629	8	472	11	85	7	1	15	11	11	1	0	179	36	5.7	5	37.6	42.7			
0700	1084	6	868	12	116	9	12	30	10	11	1	4	116	13	1.2	1	33.2	38.9			
0800	1127	4	894	20	116	9	10	32	15	17	5	1	54	9	0.8	0	31	36.7			
0900	1122	4	880	15	144	10	8	26	15	9	4	4	57	9	0.8	1	30.2	35.6			
1000	1178	5	949	17	120	15	16	31	11	9	2	2	33	5	0.4	0	30.2	34.7			
1100	1338	2	1098	23	119	15	11	34	13	16	0	3	30	2	0.1	0	29.8	34.7			
1200	1413	2	1185	19	103	13	15	32	11	18	5	7	37	6	0.4	1	29.6	34			
1300	1497	5	1248	33	122	11	11	32	8	14	0	6	33	3	0.2	0	28.6	34			
1400	1498	10	1284	31	83	25	10	25	7	10	1	4	5	1	0.1	0	19.1	28.9			
1500	1656	12	1411	38	99	17	15	33	13	13	2	2	43	6	0.4	2	25.9	32.7			
1600	1794	8	1555	45	62	22	11	51	10	9	4	10	15	1	0.1	0	22.1	30.2			
1700	1843	9	1625	47	52	12	11	60	5	10	3	5	13	5	0.3	1	22.5	30.2			
1800	1479	8	1318	40	49	9	3	35	3	10	0	2	61	11	0.7	1	29.8	35.6			
1900	1105	3	987	22	30	12	2	24	12	9	1	1	35	4	0.4	0	29.9	34.4			
2000	973	2	875	24	27	4	3	14	14	6	1	2	78	8	2.4	2	32.7	37.6			
2100	603	3	541	9	21	3	1	7	12	3	2	1	96	17	2.8	2	34.3	40			
2200	385	6	349	2	11	0	1	5	6	4	0	0	80	17	4.4	2	35.9	40.9			
2300	201	0	160	0	12	0	0	4	20	5	0	0	61	21	10.4	3	38.1	43.8			
07-19	17029	75	14315	340	1185	167	133	49	421	146	27	50	497	71	0.4	7	27.1	34.2			
06-22	20339	91	17190	406	1348	193	146	53	481	175	32	54	885	151	0.7	16	28.1	35.1			
06-00	20925	97	17699	408	1371	193	147	54	490	184	32	54	1026	189	0.9	21	28.3	35.6			
00-00	21721	104	18280	412	1488	196	149	54	506	204	32	54	1256	251	1.2	30	28.6	36			

Time	Total	Classification												JPSL 40	JPSL% 40	JSL1 46 ACPO	JSL1% 46 ACPO	JSL2 55 DFT	JSL2% 55 DFT	Mean	Vpp 85	
		1 MCL	2 SV	3 SVT	4 TB2	5 TB3	6 T4	7 ART3	8 ART4	9 ART5	10 ART6	11 BD	12 DRT									
0000	122	1	82	0	16	2	1	0	5	11	4	0	0	0	29	23.8	5	4.1	2	1.6	37.3	41.8
0100	86	0	51	0	16	0	0	0	4	10	5	0	0	0	23	26.7	4	4.7	0	0	36.5	41.6
0200	74	0	53	0	10	0	1	0	2	4	4	0	0	0	28	37.8	8	10.8	0	0	39.1	44.7
0300	61	0	44	0	8	0	0	0	2	5	2	0	0	0	20	32.8	7	11.5	1	1.6	38.7	44.3
0400	107	2	70	0	21	0	0	0	2	10	2	0	0	0	38	35.5	8	7.5	0	0	38.2	42.9
0500	358	1	289	3	41	4	1	1	3	7	7	0	1	1	113	31.6	22	6.1	2	0.6	37.9	42.5
0600	625	7	487	5	86	8	10	0	11	4	7	0	0	0	190	30.4	48	7.7	7	1.1	37.6	42.9
0700	1115	8	851	24	130	12	20	4	30	8	19	3	6	6	113	10.1	11	1	4	0.4	32.2	38.3
0800	1099	4	859	25	128	15	9	2	30	11	11	1	4	4	67	6.1	13	1.2	0	0	31.1	37.1
0900	1147	3	915	24	123	7	14	0	31	13	13	3	1	1	28	2.4	4	0.3	0	0	29.1	34.4
1000	1255	5	1020	26	122	14	11	3	22	10	14	1	7	7	38	3	4	0.3	0	0	29.9	35.1
1100	1409	10	1217	21	103	10	9	6	22	4	4	1	2	2	8	0.6	2	0.1	0	0	23.5	31.8
1200	1538	9	1299	23	114	16	14	2	35	3	20	2	1	1	24	1.6	2	0.1	0	0	26.8	33.6
1300	1569	4	1349	21	111	13	12	2	22	10	14	2	9	9	17	1.1	1	0.1	0	0	26.1	32.9
1400	1572	9	1348	29	67	25	19	7	39	1	16	1	11	11	4	0.3	0	0	0	0	17.8	26.4
1500	1686	6	1445	33	90	18	17	4	43	12	14	3	1	1	14	0.8	1	0.1	0	0	24	31.3
1600	1868	10	1647	44	74	9	13	1	46	3	15	3	3	3	7	0.4	0	0	0	0	22.1	29.3
1700	1784	13	1591	44	42	13	12	3	36	5	17	2	6	6	28	1.6	2	0.1	1	0.1	25.2	32.7
1800	1388	9	1240	30	40	5	5	0	41	9	6	2	1	1	59	4.3	8	0.6	4	0.3	31.3	36
1900	1002	2	890	25	39	4	3	0	22	8	5	2	2	2	33	3.3	10	1	2	0.2	30.7	35.1
2000	727	3	644	16	21	2	3	0	18	12	6	0	2	2	61	8.4	10	1.4	2	0.3	32.7	37.6
2100	823	6	740	16	15	7	2	1	15	16	0	1	4	4	63	7.7	13	1.6	2	0.2	29	37.1
2200	604	5	534	4	26	7	10	1	8	4	5	0	0	0	59	9.8	10	1.7	0	0	27.8	37.8
2300	271	1	233	1	11	0	0	0	6	16	3	0	0	0	48	17.7	12	4.4	0	0	35.7	41.4
07-19	17430	90	14781	344	1144	157	155	34	397	89	163	24	52	52	407	2.3	48	0.3	9	0.1	26.1	33.8
06-22	20607	108	17542	406	1305	178	173	35	463	129	181	27	60	60	754	3.7	129	0.6	22	0.1	27	34.7
06-00	21482	114	18309	411	1342	185	183	36	477	149	189	27	60	60	861	4	151	0.7	22	0.1	27.1	34.9
00-00	22290	118	18898	414	1454	191	186	37	495	196	213	27	61	61	1112	5	205	0.9	27	0.1	27.5	35.6

Time	Total	Classification												JPSL	JPSL%	JSL1	JSL1%	JSL2	JSL2%	Mean	Vpp
		1	2	3	4	5	6	7	8	9	10	11	12								
	MCL	SV	SVT	TB2	TB3	T4	ART3	ART4	ART5	ART6	BD	DRT	40	ACPO	ACPO	DFT	DFT				
0000	0	166	0	13	0	0	1	4	11	4	0	0	42	16	8	1	0.5	37.4	41.6		
0100	1	94	0	12	2	0	0	2	8	3	0	0	25	12	9.8	2	1.6	37.7	40.5		
0200	0	63	0	11	0	0	0	5	8	5	0	0	24	8	8.7	1	1.1	38	43.8		
0300	0	73	0	12	0	0	0	0	3	2	0	0	29	9	10	3	3.3	39.5	44.3		
0400	1	70	1	16	0	0	0	2	6	7	0	0	38	5	4.9	2	1.9	37.7	42.1		
0500	4	189	3	21	0	0	0	0	5	7	0	0	69	17	7.4	3	1.3	38	42.9		
0600	2	236	3	38	2	1	0	3	2	3	0	0	104	24	8.3	0	0	38.3	43.4		
0700	1	415	4	60	3	7	1	6	2	5	0	1	112	19	3.8	3	0.6	36.2	41.4		
0800	1	599	13	59	7	10	1	13	2	5	0	0	82	17	2.4	3	0.4	33.9	39.1		
0900	3	843	17	76	5	11	2	26	3	2	1	1	67	7	0.7	4	0.4	31.4	36.7		
1000	7	1122	19	50	6	6	2	28	3	4	0	2	42	8	0.6	2	0.2	30.5	35.6		
1100	3	1360	31	40	6	11	2	33	3	1	1	3	25	5	0.3	1	0.1	28.9	33.8		
1200	5	1456	47	35	20	10	5	35	1	10	1	2	4	1	0.1	0	0	21.9	28.6		
1300	11	1554	42	34	9	6	0	39	1	7	1	1	8	1	0.1	0	0	22.5	29.8		
1400	11	1512	35	42	13	8	3	31	0	6	2	1	8	0	0	0	0	23.5	30		
1500	9	1532	29	37	11	10	5	24	2	7	1	6	9	2	0.1	1	0.1	24.7	30.6		
1600	4	1496	39	44	12	7	2	34	1	2	2	5	25	5	0.3	2	0.1	27.7	33.1		
1700	3	1427	37	37	5	6	1	33	0	8	1	2	34	5	0.3	0	0	29.1	33.8		
1800	5	1093	28	22	6	5	1	28	1	2	0	0	36	6	0.5	0	0	31	35.8		
1900	3	743	10	12	8	1	1	16	3	1	1	2	72	12	1.5	3	0.4	32.3	37.6		
2000	2	531	10	9	0	0	1	7	1	4	0	0	61	15	2.7	1	0.2	33	38.3		
2100	7	412	5	14	1	0	1	3	0	3	0	0	64	25	5.6	2	0.4	34.6	39.6		
2200	1	303	2	6	1	1	0	0	0	0	0	0	77	20	6.4	3	1	37.2	41.6		
2300	0	250	1	6	1	0	0	1	1	0	0	0	64	11	4.2	4	1.5	37.3	41.4		
07-19	63	14409	341	536	103	97	25	330	19	59	10	24	452	76	0.5	16	0.1	27.3	34		
06-22	77	16331	369	609	114	99	28	359	25	70	11	26	753	152	0.8	22	0.1	28.1	34.9		
06-00	78	16884	372	621	116	100	28	360	26	70	11	26	894	183	1	29	0.2	28.3	35.3		
00-00	84	17539	376	706	118	100	29	373	67	98	11	26	1121	250	1.3	41	0.2	28.7	36		

Time	Total	Classification												JPSL 40	JPSL% 40	JSL1 46 ACPO	JSL1% 46 ACPO	JSL2 55 DFT	JSL2% 55 DFT	Mean	Vpp 85	
		1 MCL	2 SV	3 SVT	4 TB2	5 TB3	6 T4	7 ART3	8 ART4	9 ART5	10 ART6	11 BD	12 DRT									
0000	220	2	196	0	17	1	2	0	1	1	0	0	0	0	66	30	9	4.1	2	0.9	37.2	42.7
0100	125	0	107	1	13	0	0	1	0	2	1	0	0	0	46	36.8	10	8	0	0	38.8	43.6
0200	117	2	105	0	6	0	0	0	1	3	0	0	0	0	41	35	17	14.5	2	1.7	39.1	45.2
0300	115	0	108	0	3	0	0	0	2	0	2	0	0	0	33	28.7	7	6.1	0	0	37.9	41.8
0400	158	0	148	2	7	0	0	0	1	0	0	0	0	0	42	26.6	16	10.1	3	1.9	38	42.9
0500	172	2	151	1	13	0	0	0	1	2	2	0	0	0	58	33.7	16	9.3	2	1.2	38.8	43.4
0600	351	1	321	3	22	2	0	0	1	1	0	0	0	0	114	32.5	26	7.4	3	0.9	38.3	43.4
0700	450	2	399	0	41	1	1	0	2	3	0	1	0	0	129	28.7	23	5.1	5	1.1	37.8	42.9
0800	623	6	571	6	24	3	2	3	7	0	1	0	0	0	119	19.1	24	3.9	5	0.8	36.3	40.9
0900	888	11	786	18	41	7	3	0	15	4	1	1	1	1	105	11.8	19	2.1	3	0.3	33.3	38.7
1000	1215	13	1092	28	38	7	7	1	22	0	5	1	1	1	30	2.5	6	0.5	1	0.1	30.3	34.7
1100	1452	10	1321	35	40	4	3	0	28	0	8	1	2	2	12	0.8	0	0	0	0	28.1	32.7
1200	1525	4	1388	40	33	5	4	2	37	0	10	0	2	2	11	0.7	1	0.1	0	0	27.2	32
1300	1527	16	1382	43	25	7	7	2	33	2	8	1	1	1	14	0.9	2	0.1	0	0	28.3	32.9
1400	1485	6	1365	34	29	7	5	2	31	0	2	1	3	3	41	2.8	4	0.3	0	0	30.1	34.4
1500	1312	8	1222	16	23	4	6	2	22	1	6	0	2	2	61	4.6	8	0.6	4	0.3	30.9	36
1600	1035	6	956	17	32	3	3	0	14	0	4	0	0	0	115	11.1	33	3.2	5	0.5	33.3	38.7
1700	708	9	645	8	13	1	4	0	20	3	3	0	2	2	136	19.2	33	4.7	8	1.1	35.9	40.5
1800	687	4	636	10	15	3	2	0	11	0	4	0	2	2	72	10.5	15	2.2	2	0.3	33.5	38.7
1900	587	1	545	15	12	3	1	0	8	1	1	0	0	0	68	11.6	16	2.7	2	0.3	34	39.1
2000	396	5	359	11	9	0	1	0	9	0	2	0	0	0	61	15.4	14	3.5	5	1.3	34.7	40
2100	242	2	223	1	10	0	1	0	1	2	2	0	0	0	71	29.3	22	9.1	2	0.8	37.4	43.6
2200	157	3	142	0	5	1	0	0	3	1	2	0	0	0	34	21.7	8	5.1	1	0.6	36.9	41.2
2300	106	1	92	0	8	0	0	0	3	1	1	0	0	0	41	38.7	11	10.4	5	4.7	38.9	44.5
07-19	12907	95	11763	255	354	52	47	12	242	13	52	6	16	16	845	6.5	168	1.3	33	0.3	31	36.7
06-22	14483	104	13211	285	407	57	50	12	261	17	57	6	16	16	1159	8	246	1.7	45	0.3	31.5	37.4
06-00	14746	108	13445	285	420	58	50	12	267	19	60	6	16	16	1234	8.4	265	1.8	51	0.3	31.6	37.6
00-00	15653	114	14260	289	479	59	52	13	273	27	65	6	16	16	1520	9.7	340	2.2	60	0.4	32	38.3

Monday 26 March 2018

Time	Total	Classification												JPSL	JPSL%	JSL1	JSL1%	JSL2	JSL2%	Mean	Vpp
		1	2	3	4	5	6	7	8	9	10	11	12								
	MCL	SV	SVT	TB2	TB3	T4	ART3	ART4	ART5	ART6	BD	DRT	40	ACPO	ACPO	DFT	DFT				
0000	0	35	0	3	1	0	0	0	0	1	0	0	12	2	5	0	0	37.1	42.3		
0100	0	25	0	12	0	0	0	2	2	1	0	0	20	5	11.9	2	4.8	40	44.5		
0200	0	35	0	14	0	0	0	0	3	2	0	0	15	3	5.6	1	1.9	37.7	42.9		
0300	0	68	0	11	0	0	0	2	1	3	0	0	19	3	3.5	0	0	36.2	40.7		
0400	3	282	4	37	1	1	1	3	2	5	0	0	88	17	5	1	0.3	37.9	42.5		
0500	2	465	9	79	3	11	0	15	2	4	0	1	150	27	4.6	4	0.7	36.7	42.1		
0600	8	853	19	99	11	8	2	25	10	9	1	2	116	27	2.6	1	0.1	32.3	38.7		
0700	5	902	26	101	8	9	5	24	6	8	2	5	80	15	1.4	2	0.2	31.7	37.1		
0800	4	851	27	128	12	13	3	24	13	17	0	4	49	10	0.9	0	0	31.3	36		
0900	2	936	23	137	10	10	4	22	17	13	1	4	47	10	0.8	0	0	31	36		
1000	7	1079	19	123	12	10	1	34	11	15	2	5	38	10	0.8	0	0	28.9	34.4		
1100	4	1292	20	132	9	10	2	36	9	13	2	3	23	4	0.3	1	0.1	28	33.8		
1200	10	1246	35	108	9	14	3	37	9	17	0	3	29	5	0.3	0	0	29	34		
1300	9	1406	27	103	14	12	6	45	10	6	0	2	21	1	0.1	0	0	27	32.4		
1400	8	1326	28	96	17	11	8	25	7	11	2	8	13	3	0.2	0	0	23	32		
1500	10	1581	44	67	24	12	5	39	3	13	0	4	9	3	0.2	0	0	19.3	27.3		
1600	8	1617	44	38	25	16	6	43	0	5	3	5	1	1	0.1	0	0	16.8	22.8		
1700	7	1264	41	40	6	9	2	37	4	15	1	3	68	7	0.5	1	0.1	29.9	35.8		
1800	7	957	15	31	4	2	0	24	4	7	2	2	26	7	0.7	1	0.1	29.8	34		
1900	3	658	22	19	6	2	0	13	9	12	0	1	65	13	1.7	3	0.4	31.9	37.1		
2000	2	494	5	18	3	0	0	14	9	4	0	1	100	24	4.4	7	1.3	35.4	40.7		
2100	1	342	1	15	0	1	0	5	7	3	0	0	91	28	7.5	3	0.8	36.9	41.6		
2200	2	154	1	15	1	0	0	3	13	7	0	0	54	19	9.7	3	1.5	37.7	43.2		
2300	2	95	0	13	0	0	0	4	12	2	0	0	42	13	10.2	1	0.8	38.3	43.8		
07-19	81	14457	349	1104	150	128	45	390	93	140	15	48	404	76	0.4	5	0	26.4	33.8		
06-22	95	16804	396	1255	170	139	47	447	128	168	16	52	776	168	0.9	19	0.1	27.4	34.9		
06-00	99	17053	397	1283	171	139	47	454	153	177	16	52	872	200	1	23	0.1	27.6	35.1		
00-00	104	17963	410	1439	176	151	48	476	163	193	16	53	1176	257	1.2	31	0.1	28.1	36		

Site
Location
Direction

1
A49 Winwick Road -N53.412624, W2.597562
Southbound

8551 / A49 Warrington
Mar-18
Automatic Traffic Count

Tuesday 20 March 2018

Time	Total	Classification												JPSL	JPSL%	JSL1 ACPO	JSL1%	JSL2 DfT	JSL2%	Mean	Vpp
		1 MCL	2 SV	3 SVT	4 TB2	5 TB3	6 T4	7 ART3	8 ART4	9 ART5	10 ART6	11 BD	12 DRT								
0000	101	3	70	0	12	0	0	0	3	5	8	0	0	29	28.7	46	12.9	2	2	37.8	85
0100	67	0	39	0	11	0	0	0	3	9	5	0	0	26	38.8	4	6	1	1.5	38.8	43.6
0200	56	0	36	0	8	2	0	0	2	3	5	0	0	24	42.9	5	8.9	1	1.8	39.6	44.1
0300	82	0	59	0	10	1	0	0	0	9	2	0	0	44	53.7	14	17.1	3	3.7	41.2	46.8
0400	99	2	72	1	14	0	0	0	3	5	2	0	0	36	36.4	11	11.1	2	2	39.4	44.5
0500	424	5	348	4	45	4	3	0	9	3	3	0	0	213	50.2	49	11.6	5	1.2	40.1	45
0600	1060	4	896	10	78	9	10	1	33	9	9	1	0	506	47.7	136	12.8	9	0.8	40	45.2
0700	1818	9	1512	43	114	20	21	3	61	8	18	1	8	257	14.1	44	2.4	4	0.2	32.8	39.8
0800	1683	15	1402	46	61	28	27	9	67	4	18	4	2	6	0.4	2	0.1	0	0	19.4	24.8
0900	1581	8	1300	36	103	30	18	6	43	9	17	7	4	91	5.8	9	0.6	1	0.1	24.9	36.5
1000	1271	7	1042	20	125	15	7	4	29	9	11	1	1	172	13.5	24	1.9	2	0.2	32.7	39.4
1100	1327	6	1104	16	128	11	9	1	22	14	11	0	5	123	9.3	13	1	1	0.1	31	38.5
1200	1301	8	1055	18	138	14	13	4	22	15	9	0	5	152	11.7	27	2.1	2	0.2	31.6	38.9
1300	1260	2	1050	19	113	8	12	3	21	15	14	1	2	177	14	17	1.3	0	0	31.3	39.6
1400	1274	7	1004	27	134	13	15	3	25	22	15	1	8	177	13.9	25	2	2	0.2	31.5	39.6
1500	1306	5	1061	20	136	18	16	3	17	15	9	2	4	202	15.5	35	2.7	4	0.3	32.5	40
1600	1318	8	1121	21	98	14	10	0	31	7	5	1	2	248	18.8	35	2.7	4	0.3	33.3	40.7
1700	1389	8	1230	16	74	7	8	2	25	7	5	0	7	238	17.1	55	4	6	0.4	33	40.5
1800	1292	13	1147	11	70	10	3	0	21	7	6	0	4	186	14.4	37	2.9	3	0.2	32.3	39.6
1900	1007	2	912	14	44	4	4	1	10	8	7	0	1	172	17.1	29	2.9	3	0.3	33.3	40.3
2000	632	4	571	9	22	3	0	0	4	13	4	0	2	138	21.8	30	4.7	5	0.8	34.4	41.2
2100	434	1	381	3	27	1	3	0	7	5	5	1	0	94	21.7	26	6	3	0.7	35.1	41.4
2200	364	2	307	3	21	0	0	1	5	17	7	1	0	109	29.9	33	9.1	4	1.1	37.4	42.9
2300	192	2	146	2	16	1	0	0	9	9	6	0	1	63	32.8	17	8.9	2	1	38.2	43.2
07-19	16820	96	14028	293	1294	188	159	38	384	132	138	18	52	2029	12.1	323	1.9	29	0.2	30.3	39.1
06-22	19953	107	16788	329	1465	205	176	40	438	167	163	20	55	2939	14.7	544	2.7	49	0.2	31.2	39.8
06-00	20509	111	17241	334	1502	206	176	41	452	193	176	21	56	3111	15.2	594	2.9	55	0.3	31.4	39.8
00-00	21338	121	17865	339	1602	213	180	41	472	227	201	21	56	3483	16.3	690	3.2	69	0.3	31.7	40.3

Site
Location
Direction

1
A49 Winwick Road -N53.412624, W2.597562
Southbound

8551 / A49 Warrington
Mar-18
Automatic Traffic Count

Wednesday 21 March 2018

Time	Total	Classification												JPSL	JPSL%	JSL1 ACPO	JSL1%	JSL2 DfT	JSL2%	Mean	Vpp
		1 MCL	2 SV	3 SVT	4 TB2	5 TB3	6 T4	7 ART3	8 ART4	9 ART5	10 ART6	11 BD	12 DRT								
0000	86	1	63	0	8	0	0	0	1	10	3	0	0	32	37.2	11	12.8	0	0	38.8	45.2
0100	65	0	39	0	10	0	0	0	2	6	8	0	0	22	33.8	5	7.7	0	0	38.7	41.8
0200	54	0	34	0	9	0	0	0	0	6	5	0	0	18	33.3	6	11.1	1	1.9	39.5	43.8
0300	78	0	56	1	13	2	0	0	1	4	1	0	0	28	35.9	8	10.3	1	1.3	39.2	44.1
0400	92	0	59	1	18	1	0	0	2	6	4	0	0	37	40.2	13	14.1	1	1.1	39.7	45.2
0500	399	7	328	6	32	5	6	0	6	4	5	0	0	204	51.1	57	14.3	5	1.3	40.6	45.6
0600	1061	8	888	12	88	7	12	3	27	2	11	1	2	532	50.1	149	14	7	0.7	40.4	45.6
0700	1806	6	1491	56	122	18	18	3	58	14	9	6	5	263	14.6	47	2.6	1	0.1	33.3	39.8
0800	1735	14	1438	51	78	21	20	7	73	5	16	2	10	14	0.8	1	0.1	0	0	21.8	29.1
0900	1605	8	1318	30	116	20	20	6	51	7	14	7	8	113	7	12	0.7	0	0	28	36.7
1000	1585	7	1271	22	141	15	15	3	46	14	25	10	16	79	5	11	0.7	1	0.1	29.2	36.7
1100	1488	9	1172	22	160	18	18	2	28	25	21	3	10	64	4.3	10	0.7	0	0	28.5	36.5
1200	1487	4	1218	25	144	12	11	10	31	9	11	4	8	100	6.7	23	1.5	1	0.1	29.2	37.1
1300	1404	6	1170	19	117	14	12	7	32	9	15	0	3	147	10.5	18	1.3	0	0	31	38.7
1400	1405	8	1156	14	137	14	13	3	26	17	11	2	4	152	10.8	19	1.4	1	0.1	30.7	38.7
1500	1321	3	1105	14	121	13	12	4	22	11	10	2	4	157	11.9	23	1.7	2	0.2	31.5	39.1
1600	1345	6	1155	22	89	6	6	5	29	9	14	1	3	223	16.6	32	2.4	0	0	32.4	40.3
1700	1267	7	1146	15	48	5	5	2	23	5	6	1	4	229	18.1	39	3.1	1	0.1	33.3	40.5
1800	1303	10	1156	14	68	10	3	1	27	7	4	1	2	110	8.4	17	1.3	4	0.3	31.1	37.8
1900	1005	5	905	9	45	7	5	1	13	9	3	1	2	101	10	21	2.1	2	0.2	31.4	38.5
2000	661	2	606	4	28	1	0	0	5	6	7	0	2	89	13.5	16	2.4	3	0.5	33.9	39.6
2100	426	0	378	6	19	2	2	0	3	10	5	0	1	76	17.8	19	4.5	2	0.5	34.7	40.7
2200	358	2	305	4	17	1	0	0	7	15	5	0	2	118	33	31	8.7	4	1.1	37.6	43.4
2300	220	0	179	1	19	1	1	0	5	10	4	0	0	85	38.6	25	11.4	10	4.5	39.1	44.3
07-19	17751	88	14796	304	1341	166	153	53	446	132	156	39	77	1651	9.3	252	1.4	11	0.1	29.8	38
06-22	20904	103	17573	335	1521	183	172	57	494	159	182	41	84	2449	11.7	457	2.2	25	0.1	30.7	38.9
06-00	21482	105	18057	340	1557	185	173	57	506	184	191	41	86	2652	12.3	513	2.4	39	0.2	30.9	39.1
00-00	22256	113	18636	348	1647	193	180	57	518	220	217	41	86	2993	13.4	613	2.8	47	0.2	31.2	39.4

Site
Location
Direction

1
A49 Winwick Road -N53.412624, W2.597562
Southbound

8551 / A49 Warrington
Mar-18
Automatic Traffic Count

Thursday 22 March 2018

Time	Total	Classification												JPSL 40	JPSL% 40	JSL1 46 ACPO	JSL1% 46 ACPO	JSL2 55 DfT	JSL2% 55 DfT	Mean	Vpp 85
		1 MCL	2 SV	3 SVT	4 TB2	5 TB3	6 T4	7 ART3	8 ART4	9 ART5	10 ART6	11 BD	12 DRT								
0000	104	2	82	0	8	0	0	0	0	6	5	0	1	54	51.9	16	15.4	2	1.9	40.4	45.6
0100	66	1	45	0	7	1	0	0	0	7	3	0	0	27	40.9	12	18.2	2	3	40	46.3
0200	47	1	27	0	8	0	0	0	0	1	5	0	0	19	40.4	5	10.6	0	0	39.2	43.6
0300	73	2	45	0	16	0	1	0	0	5	2	0	0	33	45.2	10	13.7	2	2.7	39.9	45
0400	111	0	79	0	20	1	0	0	0	5	2	0	0	43	38.7	12	10.8	0	0	39.5	44.3
0500	424	8	350	4	34	5	2	0	0	7	4	1	1	232	54.7	60	14.2	10	2.4	40.7	45.6
0600	1106	7	925	15	90	6	7	1	33	6	11	1	4	527	47.6	119	10.8	11	1	40	44.7
0700	1830	9	1505	53	105	16	23	7	59	14	24	1	14	237	13	25	1.4	2	0.1	32.8	39.4
0800	1806	12	1494	51	89	13	21	8	73	7	23	4	11	18	1	4	0.2	0	0	23.3	31.3
0900	1601	9	1347	23	115	24	18	6	28	11	13	1	6	88	5.5	8	0.5	1	0.1	26.3	36.2
1000	1363	6	1122	15	134	10	16	3	31	4	19	1	2	150	11	19	1.4	2	0.1	31.5	38.7
1100	1348	4	1104	18	136	18	14	3	24	8	12	2	5	167	12.4	17	1.3	0	0	32.2	39.1
1200	1352	13	1116	13	125	18	17	2	23	9	6	5	5	121	8.9	21	1.6	2	0.1	28.7	38
1300	1408	6	1176	17	118	16	18	3	30	5	13	3	3	159	11.3	18	1.3	1	0.1	31.5	38.7
1400	1421	7	1161	28	127	14	12	2	28	27	9	3	3	185	13	26	1.8	5	0.4	32	39.4
1500	1303	6	1085	16	122	10	15	2	21	7	12	3	4	175	13.4	20	1.5	0	0	32.1	39.4
1600	1381	11	1194	17	93	6	9	0	21	4	17	2	7	180	13	32	2.3	7	0.5	32.2	39.1
1700	1401	6	1245	23	73	8	7	1	21	7	5	2	3	241	17.2	38	2.7	3	0.2	32.7	40.3
1800	1263	11	1128	11	56	7	6	0	23	8	7	2	4	182	14.4	41	3.2	4	0.3	32.4	39.8
1900	1003	6	893	11	52	4	4	1	12	9	8	1	2	105	10.5	14	1.4	1	0.1	31.7	38.5
2000	708	1	631	3	34	6	3	0	6	12	12	0	0	140	19.8	29	4.1	5	0.7	34	41.2
2100	437	1	390	4	20	4	2	0	4	5	5	0	2	82	18.8	12	2.7	2	0.5	34.7	40.7
2200	360	5	305	3	16	3	0	0	5	13	8	1	1	78	21.7	18	5	2	0.6	36.6	41.2
2300	204	0	175	1	8	1	0	0	8	7	4	0	0	60	29.4	17	8.3	4	2	38.3	42.5
07-19	17477	100	14677	285	1293	160	176	37	382	111	160	29	67	1903	10.9	269	1.5	27	0.2	30.4	38.7
06-22	20731	115	17516	318	1489	180	192	39	437	143	196	31	75	2757	13.3	443	2.1	46	0.2	31.2	39.4
06-00	21295	120	17996	322	1513	184	192	39	450	163	208	32	76	2895	13.6	478	2.2	52	0.2	31.4	39.4
00-00	22120	134	18624	326	1606	191	195	39	467	198	229	33	78	3303	14.9	593	2.7	68	0.3	31.7	39.8

Site
Location
Direction

1
A49 Winwick Road -N53.412624, W2.597562
Southbound

8551 / A49 Warrington
Mar-18
Automatic Traffic Count

Friday 23 March 2018

Time	Total	Classification												JPSL 40	JPSL% 40	JSL1 46 ACPO	JSL1% 46 ACPO	JSL2 55 DfT	JSL2% 55 DfT	Mean	Vpp 85
		1 MCL	2 SV	3 SVT	4 TB2	5 TB3	6 T4	7 ART3	8 ART4	9 ART5	10 ART6	11 BD	12 DRT								
0000	98	2	64	0	17	0	0	0	1	8	6	0	0	30	30.6	6	6.1	1	1	37.7	41.8
0100	67	1	45	0	8	0	0	0	5	5	3	0	0	23	34.3	4	6	0	0	38.3	43.4
0200	66	1	37	1	11	1	1	1	1	8	4	0	0	24	36.4	3	4.5	0	0	38.4	42.9
0300	60	0	47	0	7	0	0	0	1	4	1	0	0	28	46.7	6	10	0	0	39.6	44.5
0400	95	1	73	0	13	0	0	0	2	2	4	0	0	35	36.8	11	11.6	1	1.1	39.3	44.1
0500	398	9	324	5	33	5	6	0	8	3	4	0	1	180	45.2	52	13.1	8	2	40.1	45.2
0600	1057	6	859	16	102	7	18	1	18	8	20	0	2	493	46.6	113	10.7	9	0.9	39.7	44.7
0700	1827	8	1484	51	124	25	19	9	68	9	26	1	3	225	12.3	33	1.8	1	0.1	31.5	39.1
0800	1847	8	1529	33	134	16	22	6	52	7	24	6	10	75	4.1	9	0.5	0	0	29.2	36
0900	1510	7	1233	21	135	18	16	7	42	7	15	2	7	177	11.7	18	1.2	0	0	31.2	38.9
1000	1338	6	1079	16	153	13	13	3	18	15	16	2	4	156	11.7	24	1.8	1	0.1	31.9	38.9
1100	1395	12	1155	18	134	11	18	3	21	9	12	1	1	160	11.5	30	2.2	1	0.1	31.4	38.7
1200	1420	9	1188	21	130	8	16	4	22	11	9	0	2	108	7.6	19	1.3	2	0.1	30.3	37.6
1300	1471	8	1232	19	129	15	12	8	24	7	11	2	4	166	11.3	20	1.4	4	0.3	30.5	38.9
1400	1396	6	1157	12	113	18	21	4	32	8	18	2	5	109	7.8	13	0.9	3	0.2	28.8	37.8
1500	1400	9	1173	23	110	17	14	2	26	13	8	3	2	186	13.3	27	1.9	3	0.2	31.9	39.4
1600	1304	11	1125	19	71	8	6	5	33	9	8	1	8	230	17.6	42	3.2	4	0.3	32.5	40.7
1700	1395	10	1256	10	62	6	7	1	22	10	8	0	3	237	17	43	3.1	3	0.2	33	40.3
1800	1430	4	1285	25	52	9	9	5	28	3	8	1	1	134	9.4	26	1.8	1	0.1	30.9	38.3
1900	1082	5	961	15	54	4	4	0	19	12	8	0	0	126	11.6	37	3.4	3	0.3	31.8	38.9
2000	698	4	628	4	30	3	2	0	7	10	9	0	1	126	18.1	30	4.3	2	0.3	34.4	40.5
2100	507	1	457	3	25	2	0	0	7	7	4	0	1	126	24.9	22	4.3	2	0.4	35.9	42.3
2200	436	6	385	1	16	1	1	0	4	12	8	1	1	141	32.3	22	5	4	0.9	37.3	42.3
2300	287	1	247	0	20	2	0	0	6	9	2	0	0	75	26.1	14	4.9	2	0.7	36.8	41.8
07-19	17733	98	14896	268	1347	164	173	57	388	108	163	21	50	1963	11.1	304	1.7	23	0.1	31	38.7
06-22	21077	114	17801	306	1558	180	197	58	439	145	204	21	54	2834	13.4	506	2.4	39	0.2	31.7	39.4
06-00	21800	121	18433	307	1594	183	198	58	449	166	214	22	55	3050	14	542	2.5	45	0.2	31.9	39.6
00-00	22584	135	19023	313	1683	189	205	59	467	196	236	22	56	3370	14.9	624	2.8	55	0.2	32.2	39.8

Site
Location
Direction

1
A49 Winwick Road -N53.412624, W2.597562
Southbound

8551 / A49 Warrington
Mar-18
Automatic Traffic Count

Saturday 24 March 2018

Time	Total	Classification												JPSL	JPSL%	JSL1 ACPO	JSL1%	JSL2 DfT	JSL2%	Mean	Vpp
		1 MCL	2 SV	3 SVT	4 TB2	5 TB3	6 T4	7 ART3	8 ART4	9 ART5	10 ART6	11 BD	12 DRT								
0000	177	1	156	0	6	1	2	1	2	2	5	1	0	40	22.6	10	5.6	0	0	37.2	85
0100	120	1	93	0	6	0	0	0	2	9	8	0	1	39	32.5	9	7.5	1	0.8	38.1	43.4
0200	82	0	62	1	9	0	0	0	1	5	4	0	0	28	34.1	8	9.8	2	2.4	38.5	44.5
0300	90	0	67	0	13	1	0	0	2	4	2	1	0	40	44.4	11	12.2	1	1.1	39	43.8
0400	109	1	84	1	18	1	0	0	0	4	0	0	0	33	30.3	10	9.2	0	0	38.3	42.7
0500	215	1	182	0	23	2	0	0	1	6	0	0	0	82	38.1	20	9.3	5	2.3	39.1	43.6
0600	385	3	324	2	43	2	2	1	7	0	1	0	0	182	47.3	44	11.4	5	1.3	40.4	44.7
0700	602	0	507	11	65	1	3	1	9	2	2	1	0	265	44	71	11.8	7	1.2	39.7	44.5
0800	1092	4	961	14	66	6	6	1	23	4	6	0	1	247	22.6	55	5	0.5	35.4	41.4	
0900	1238	2	1098	22	67	7	10	0	24	3	5	0	0	228	18.4	30	2.4	3	0.2	33.3	40.5
1000	1459	7	1309	19	58	16	9	2	27	3	6	0	3	170	11.7	32	2.2	3	0.2	31.2	39.1
1100	1539	10	1405	17	48	7	10	1	22	5	10	1	3	98	6.4	15	1	2	0.1	29.7	37.4
1200	1504	14	1351	24	48	17	9	2	24	3	5	0	7	104	6.9	16	1.1	1	0.1	28.6	37.6
1300	1499	14	1377	16	48	5	9	2	18	6	3	0	1	138	9.2	28	1.9	4	0.3	30	38
1400	1385	10	1286	13	39	7	7	1	16	1	2	0	3	128	9.2	21	1.5	2	0.1	29.5	38.3
1500	1400	14	1296	16	44	3	5	3	9	5	2	0	3	130	9.3	24	1.7	2	0.1	29.5	37.8
1600	1255	5	1151	21	40	5	8	1	16	1	5	0	2	179	14.3	35	2.8	1	0.1	31.5	39.6
1700	1190	7	1090	11	42	6	6	0	16	2	6	0	4	188	15.8	43	3.6	3	0.3	32.2	40.3
1800	1102	5	1014	7	45	3	5	1	14	3	5	0	0	192	17.4	28	2.5	2	0.2	32.7	40.5
1900	825	2	764	7	33	3	1	0	13	0	2	0	0	154	18.7	32	3.9	5	0.6	34.1	40.9
2000	550	2	519	4	13	2	0	0	6	1	2	0	1	101	18.4	18	3.3	3	0.5	34.5	40.7
2100	456	2	433	4	12	1	0	0	2	2	0	0	0	120	26.3	19	4.2	5	1.1	36.6	42.5
2200	344	0	329	0	14	1	0	0	0	0	0	0	0	90	26.2	22	6.4	5	1.5	37.5	41.4
2300	287	0	262	3	17	0	0	0	5	0	0	0	0	89	31	19	6.6	1	0.3	38	41.8
07-19	15265	92	13845	191	610	83	87	15	218	38	57	2	27	2067	13.5	398	2.6	35	0.2	31.4	39.4
06-22	17481	101	15885	208	711	91	90	16	246	41	62	2	28	2624	15	511	2.9	53	0.3	31.9	39.8
06-00	18112	101	16476	211	742	92	90	16	251	41	62	2	28	2803	15.5	552	3	59	0.3	32.1	40
00-00	18905	105	17120	213	817	97	92	17	259	71	81	4	29	3065	16.2	620	3.3	68	0.4	32.4	40.3

Site
Location
Direction

1
A49 Winwick Road -N53.412624, W2.597562
Southbound

8551 / A49 Warrington
Mar-18
Automatic Traffic Count

Sunday 25 March 2018

Time	Total	Classification												JPSL 40	JPSL% 40	JSL1 46 ACPO	JSL1% 46	JSL2 55 DfT	JSL2% 55 DfT	Mean	Vpp 85	
		1 MCL	2 SV	3 SVT	4 TB2	5 TB3	6 T4	7 ART3	8 ART4	9 ART5	10 ART6	11 BD	12 DRT									
0000	205	0	188	2	11	2	0	0	0	0	0	0	0	0	87	42.4	15	7.3	1	0.5	39.2	43.4
0100	121	2	96	0	19	0	0	0	0	1	2	1	2	1	55	45.5	15	12.4	1	0.8	40.1	45
0200	111	0	104	0	6	0	0	0	0	0	1	0	0	0	51	45.9	12	10.8	2	1.8	39.7	44.1
0300	94	0	86	0	4	1	0	0	0	0	2	1	0	0	42	44.7	11	11.7	0	0	39.7	44.5
0400	123	2	115	0	4	0	0	0	0	0	2	0	0	0	60	48.8	20	16.3	3	2.4	40.4	46.1
0500	210	0	186	1	14	3	0	0	0	3	3	0	0	0	107	51	29	13.8	3	1.4	40.5	45.2
0600	318	1	285	2	22	0	0	0	0	3	1	4	0	0	167	52.5	59	18.6	6	1.9	41.2	46.8
0700	365	1	329	3	24	2	1	1	0	0	3	1	0	0	173	47.4	41	11.2	2	0.5	39.6	44.7
0800	654	2	597	7	29	3	1	0	0	11	3	1	0	0	257	39.3	75	11.5	9	1.4	39.2	44.5
0900	1095	6	1004	10	47	2	1	1	1	15	1	5	1	2	301	27.5	69	6.3	11	1	35.7	42.5
1000	1435	12	1317	25	37	8	5	0	0	19	0	9	0	3	138	9.6	22	1.5	2	0.1	30.7	38.7
1100	1421	15	1300	24	41	7	6	2	2	19	2	2	0	3	124	8.7	18	1.3	1	0.1	29.9	37.8
1200	1532	17	1420	14	34	7	8	1	1	25	2	3	0	1	112	7.3	27	1.8	1	0.1	28.7	37.4
1300	1331	10	1243	15	29	4	5	1	1	14	1	4	1	4	129	9.7	26	2	3	0.2	29.4	38.7
1400	1352	16	1265	14	32	6	2	0	0	13	1	2	0	1	179	13.2	32	2.4	4	0.3	31.1	39.4
1500	1010	13	914	20	31	4	2	0	0	18	3	4	0	1	239	23.7	57	5.6	10	1	34.8	41.6
1600	901	13	816	14	35	1	5	1	1	11	1	4	0	0	240	26.6	65	7.2	9	1	35.4	42.3
1700	802	11	744	6	23	1	1	0	0	11	2	3	0	0	301	37.5	90	11.2	13	1.6	38.3	44.5
1800	735	4	669	8	34	3	1	0	0	11	1	1	1	2	205	27.9	49	6.7	5	0.7	36.1	42.7
1900	531	5	502	4	13	2	1	0	0	2	1	1	0	0	140	26.4	37	7	5	0.9	36.1	42.3
2000	352	0	325	1	12	1	2	0	0	6	1	4	0	0	105	29.8	18	5.1	1	0.3	36.4	42.1
2100	228	2	214	0	7	0	0	0	0	3	1	1	0	0	93	40.8	32	14	9	3.9	39.6	45.4
2200	144	0	136	0	5	0	0	0	0	1	0	2	0	0	43	29.9	10	6.9	4	2.8	38.5	42.9
2300	87	2	78	0	5	0	0	0	0	0	0	2	0	0	28	32.2	4	4.6	0	0	37.9	43.4
07-19	12633	120	11618	160	396	48	38	7	7	167	20	39	3	17	2398	19	571	4.5	70	0.6	32.9	40.9
06-22	14062	128	12944	167	450	51	41	7	7	181	24	49	3	17	2903	20.6	717	5.1	91	0.6	33.4	41.4
06-00	14293	130	13158	167	460	51	41	7	7	182	24	53	3	17	2974	20.8	731	5.1	95	0.7	33.5	41.4
00-00	15157	134	13933	170	518	57	41	7	7	188	34	55	3	17	3376	22.3	833	5.5	105	0.7	33.8	41.6



Site
Location
Direction

1
A49 Winwick Road -N53.412624, W2.597562
Southbound

8551 / A49 Warrington
Mar-18
Automatic Traffic Count

Monday 26 March 2018

Time	Total	Classification												JPSL	JPSL%	JSL1 ACPO	JSL1%	JSL2 DfT	JSL2%	Mean	Vpp	
		1 MCL	2 SV	3 SVT	4 TB2	5 TB3	6 T4	7 ART3	8 ART4	9 ART5	10 ART6	11 BD	12 DRT									
0000	48	0	43	0	4	0	0	0	1	0	0	0	0	0	27	56.3	9	18.8	1	2.1	41.5	85
0100	44	0	34	0	4	0	0	0	0	4	2	0	0	0	18	40.9	4	9.1	0	0	39	43.4
0200	55	1	44	0	8	0	0	0	1	0	1	0	0	0	23	41.8	7	12.7	0	0	40.6	45.2
0300	95	1	74	0	15	0	1	0	2	1	1	0	0	0	43	45.3	14	14.7	1	1.1	40.4	45.9
0400	403	6	343	2	26	7	1	0	10	4	3	0	1	213	52.9	48	11.9	4	1	40.2	45	
0500	985	6	814	11	92	15	10	2	21	7	7	0	0	417	42.3	95	9.6	7	0.7	39.3	44.5	
0600	1769	8	1502	34	100	14	18	5	52	5	18	5	8	204	11.5	21	1.2	0	0	31.5	39.1	
0700	1777	10	1479	48	90	16	23	5	71	8	16	5	6	12	0.7	2	0.1	0	0	21.4	29.3	
0800	1521	6	1243	30	134	13	22	4	45	6	15	1	2	116	7.6	15	1	0	0	27.9	37.4	
0900	1395	6	1113	23	153	17	14	2	30	9	19	2	7	196	14.1	21	1.5	2	0.1	31.6	39.6	
1000	1335	8	1088	16	155	7	13	1	22	12	11	0	2	134	10	22	1.6	0	0	30.9	38.5	
1100	1417	3	1206	16	108	17	15	2	25	8	13	3	1	123	8.7	16	1.1	1	0.1	30.1	38.3	
1200	1398	10	1157	25	126	9	8	4	36	7	12	2	2	128	9.2	12	0.9	3	0.2	29.6	38	
1300	1370	5	1155	21	110	14	12	0	27	6	12	1	7	132	9.6	19	1.4	2	0.1	30.7	38.5	
1400	1335	11	1127	13	107	22	5	3	26	5	12	1	3	224	16.8	32	2.4	2	0.1	32.3	40.3	
1500	1328	7	1161	13	97	6	4	1	26	2	7	1	3	200	15.1	38	2.9	2	0.2	33.1	39.8	
1600	1306	6	1141	23	76	8	6	2	30	6	4	1	3	290	22.2	56	4.3	5	0.4	34	41.4	
1700	1356	15	1199	18	71	6	5	2	25	6	8	0	1	205	15.1	29	2.1	3	0.2	32.7	40	
1800	1008	3	893	9	54	7	6	1	19	4	10	1	1	153	15.2	34	3.4	4	0.4	32.6	40	
1900	694	0	623	9	30	2	2	0	10	8	9	0	1	134	19.3	22	3.2	3	0.4	34.1	40.7	
2000	422	2	375	1	18	3	0	0	8	12	3	0	0	100	23.7	25	5.9	2	0.5	36.2	41.6	
2100	343	4	295	1	14	1	2	0	8	9	9	0	0	110	32.1	22	6.4	2	0.6	37.5	43.2	
2200	221	1	178	0	19	0	0	0	8	9	6	0	0	82	37.1	26	11.8	3	1.4	38.8	44.3	
2300	95	0	74	1	6	0	0	0	0	12	2	0	0	34	35.8	6	6.3	0	0	38.9	42.5	
07-19	16546	90	13962	255	1281	142	133	27	382	79	139	18	38	1913	11.6	296	1.8	24	0.1	30.3	38.9	
06-22	19774	104	16757	300	1443	162	155	32	460	113	178	23	47	2461	12.4	386	2	31	0.2	30.8	39.1	
06-00	20090	105	17009	301	1468	162	155	32	468	134	186	23	47	2577	12.8	418	2.1	34	0.2	30.9	39.4	
00-00	21720	119	18361	314	1617	184	167	34	503	150	200	23	48	3318	15.3	595	2.7	47	0.2	31.6	40	

1

A49 Winwick Road -N53.412624, W2.597562
Northbound

7 Day Average Northbound

Time	Total
0000	130
0100	84
0200	76
0300	79
0400	143
0500	351
0600	588
0700	930
0800	973
0900	1075
1000	1218
1100	1401
1200	1469
1300	1553
1400	1581
1500	1635
1600	1682
1700	1511
1800	1249
1900	918
2000	713
2100	535
2200	344
2300	197
07-19	16277
06-00	19571
00-00	20435

AAWT Factor 14.8169

5 Day Average Northbound

Time	Total
0000	99
0100	68
0200	65
0300	70
0400	148
0500	411
0600	694
0700	1110
0800	1096
0900	1130
1000	1212
1100	1372
1200	1426
1300	1527
1400	1584
1500	1693
1600	1818
1700	1662
1800	1373
1900	1007
2000	806
2100	611
2200	387
2300	203
07-19	17004
06-00	20712
00-00	21574

AAWT Factor 15.0174

1

A49 Winwick Road -N53.412624, W2.597562
Southbound

7 Day Average Southbound

Time	Total
0000	117
0100	79
0200	67
0300	82
0400	147
0500	436
0600	965
0700	1432
0800	1477
0900	1432
1000	1398
1100	1419
1200	1428
1300	1392
1400	1367
1500	1295
1600	1259
1700	1257
1800	1162
1900	878
2000	575
2100	404
2200	318
2300	196
07-19	16318
06-00	19654
00-00	20583

AAWT Factor 13.3655

5 Day Average Northbound

Time	Total
0000	87
0100	62
0200	56
0300	78
0400	160
0500	526
0600	1211
0700	1812
0800	1718
0900	1538
1000	1378
1100	1395
1200	1392
1300	1383
1400	1366
1500	1332
1600	1331
1700	1362
1800	1259
1900	958
2000	624
2100	429
2200	348
2300	200
07-19	17265
06-00	21035
00-00	22004

AAWT Factor 13.6592

Appendix 2

ATC Data – A50

Warrington ATC K, A50

Produced by Road Data Services Ltd.

Channel 1 - Westbound

Vehicle Flow

Week 1

Hr Ending	30/03/2019 Saturday	31/03/2019 Sunday	01/04/2019 Monday	02/04/2019 Tuesday	03/04/2019 Wednesday	04/04/2019 Thursday	05/04/2019 Friday	5 Day Ave	7 Day Ave
1	84	82	40	28	26	20	35	30	45
2	37	40	14	16	22	19	19	18	24
3	24	0	12	6	11	9	11	10	10
4	23	32	10	7	25	10	19	14	18
5	21	23	37	25	30	26	22	28	26
6	70	61	141	152	165	168	153	156	130
7	105	74	195	214	259	242	231	228	189
8	209	91	571	596	609	632	562	594	467
9	285	133	708	678	765	742	667	712	568
10	474	269	584	591	643	614	623	611	543
11	495	405	455	493	425	448	476	459	457
12	566	482	402	492	448	482	523	469	485
13	532	553	514	481	536	481	553	513	521
14	551	494	482	463	487	491	504	485	496
15	483	462	486	468	476	488	520	488	483
16	500	399	584	626	543	590	647	598	556
17	447	283	743	731	747	740	719	736	630
18	432	324	707	723	703	669	684	697	606
19	378	327	635	643	661	642	645	645	562
20	269	251	328	357	325	350	322	336	315
21	206	165	223	225	241	236	214	228	216
22	163	138	170	193	190	195	185	187	176
23	117	97	109	121	113	125	152	124	119
24	111	58	46	60	53	45	89	59	66
7-19	5352	4222	6871	6985	7043	7019	7123	7008	6374
6-22	6095	4850	7787	7974	8058	8042	8075	7987	7269
6-24	6323	5005	7942	8155	8224	8212	8316	8170	7454
0-24	6582	5243	8196	8389	8503	8464	8575	8425	7707

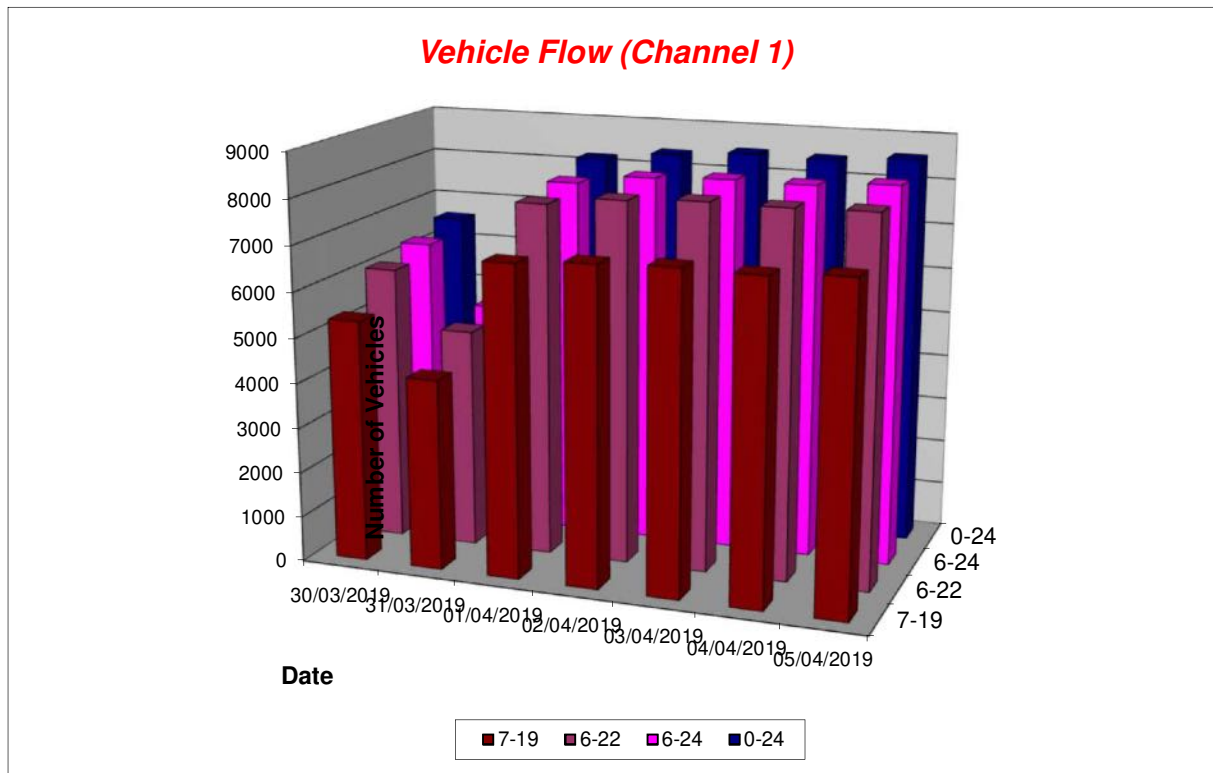

Warrington ATC K, A50

Produced by Road Data Services Ltd.

Channel 2 - Eastbound

Vehicle Flow

Week 1

Hr Ending	30/03/2019 Saturday	31/03/2019 Sunday	01/04/2019 Monday	02/04/2019 Tuesday	03/04/2019 Wednesday	04/04/2019 Thursday	05/04/2019 Friday	5 Day Ave	7 Day Ave
1	84	68	35	40	37	31	42	37	48
2	43	34	16	14	16	14	17	15	22
3	22	0	11	13	9	10	11	11	11
4	23	28	11	8	10	18	15	12	16
5	26	22	29	33	30	32	26	30	28
6	56	38	93	92	112	107	106	102	86
7	88	58	252	259	285	259	231	257	205
8	117	65	892	817	845	880	809	849	632
9	205	100	611	620	602	563	575	594	468
10	354	164	494	487	523	543	540	517	444
11	402	315	334	346	350	344	360	347	350
12	453	446	404	385	429	407	411	407	419
13	495	446	422	433	439	424	483	440	449
14	491	439	417	450	441	438	418	433	442
15	459	438	450	465	520	522	523	496	482
16	420	470	477	470	450	470	441	462	457
17	435	367	694	618	634	658	558	632	566
18	435	330	703	663	654	567	633	644	569
19	438	320	594	616	587	547	628	594	533
20	361	272	404	403	391	376	356	386	366
21	236	232	316	304	355	323	298	319	295
22	174	136	197	198	237	220	216	214	197
23	141	89	125	139	131	165	191	150	140
24	105	71	73	67	71	86	102	80	82
7-19	4704	3900	6492	6370	6474	6363	6379	6416	5812
6-22	5563	4598	7661	7534	7742	7541	7480	7592	6874
6-24	5809	4758	7859	7740	7944	7792	7773	7822	7096
0-24	6063	4948	8054	7940	8158	8004	7990	8029	7308

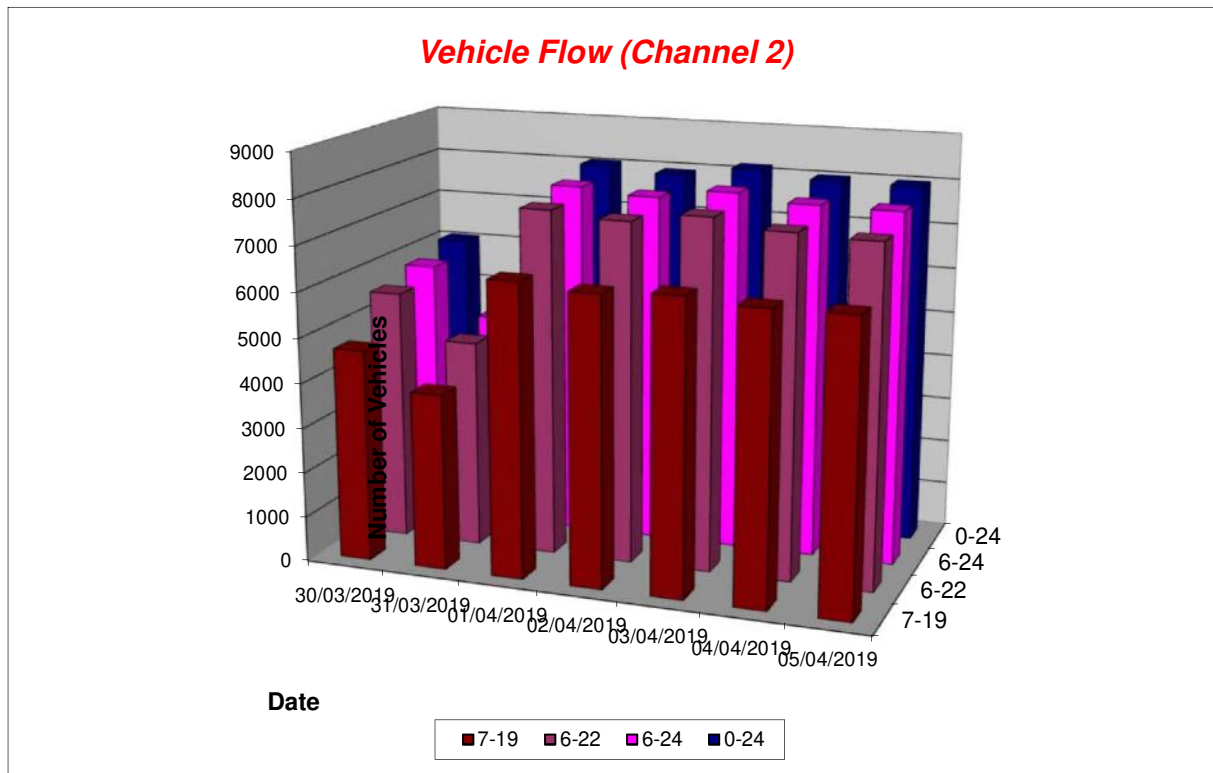

A50

Westbound

7 Day Average Westbound

Time	Total
0000	45
0100	24
0200	10
0300	18
0400	26
0500	130
0600	189
0700	467
0800	568
0900	543
1000	457
1100	485
1200	521
1300	496
1400	483
1500	556
1600	630
1700	606
1800	562
1900	315
2000	216
2100	176
2200	119
2300	66
07-19	6374
06-00	7454
00-00	7707

AADT Factor 10.9387

5 Day Average Westbound

Time	Total
0000	30
0100	18
0200	10
0300	14
0400	28
0500	156
0600	228
0700	594
0800	712
0900	611
1000	459
1100	469
1200	513
1300	485
1400	488
1500	598
1600	736
1700	697
1800	645
1900	336
2000	228
2100	187
2200	124
2300	59
07-19	7008
06-00	8170
00-00	8425

AAWT Factor 11.5949

A50

Eastbound

7 Day Average Eastbound

Time	Total
0000	48
0100	22
0200	11
0300	16
0400	28
0500	86
0600	205
0700	632
0800	468
0900	444
1000	350
1100	419
1200	449
1300	442
1400	482
1500	457
1600	566
1700	569
1800	533
1900	366
2000	295
2100	197
2200	140
2300	82
07-19	5812
06-00	7096
00-00	7308

AADT Factor 11.8045

5 Day Average Eastbound

Time	Total
0000	37
0100	15
0200	11
0300	12
0400	30
0500	102
0600	257
0700	849
0800	594
0900	517
1000	347
1100	407
1200	440
1300	433
1400	496
1500	462
1600	632
1700	644
1800	594
1900	386
2000	319
2100	214
2200	150
2300	80
07-19	6416
06-00	7822
00-00	8029

AAWT Factor 12.6338

Appendix 3

ATC Data – Poplars Avenue

Warrington ATC F, Poplars Avenue

Produced by Road Data Services Ltd.

Channel 1 - Westbound

Vehicle Flow

Week 1

Hr Ending	30/03/2019 Saturday	31/03/2019 Sunday	01/04/2019 Monday	02/04/2019 Tuesday	03/04/2019 Wednesday	04/04/2019 Thursday	05/04/2019 Friday	5 Day Ave	7 Day Ave
1	20	24	12	14	14	12	12	13	15
2	14	15	5	2	4	4	5	4	7
3	8	0	1	4	2	3	2	2	3
4	9	8	7	6	5	3	3	5	6
5	11	18	7	14	16	13	11	12	13
6	30	17	42	35	43	44	37	40	35
7	32	24	58	62	76	73	78	69	58
8	67	45	143	140	129	126	130	134	111
9	115	57	183	187	174	146	163	171	146
10	162	110	136	142	178	146	172	155	149
11	180	147	134	142	135	174	170	151	155
12	207	207	143	144	156	175	172	158	172
13	214	248	170	143	156	147	172	158	179
14	232	228	179	168	185	162	239	187	199
15	233	220	186	155	195	169	189	179	192
16	194	189	222	242	246	213	282	241	227
17	208	151	300	275	276	277	291	284	254
18	195	164	276	301	331	325	284	303	268
19	178	127	190	221	224	226	266	225	205
20	129	128	160	160	172	149	146	157	149
21	100	102	101	115	124	116	98	111	108
22	73	70	80	82	95	77	85	84	80
23	48	37	52	49	36	55	61	51	48
24	41	22	24	15	22	32	38	26	28
7-19	2185	1893	2262	2260	2385	2286	2530	2345	2257
6-22	2519	2217	2661	2679	2852	2701	2937	2766	2652
6-24	2608	2276	2737	2743	2910	2788	3036	2843	2728
0-24	2700	2358	2811	2818	2994	2867	3106	2919	2808

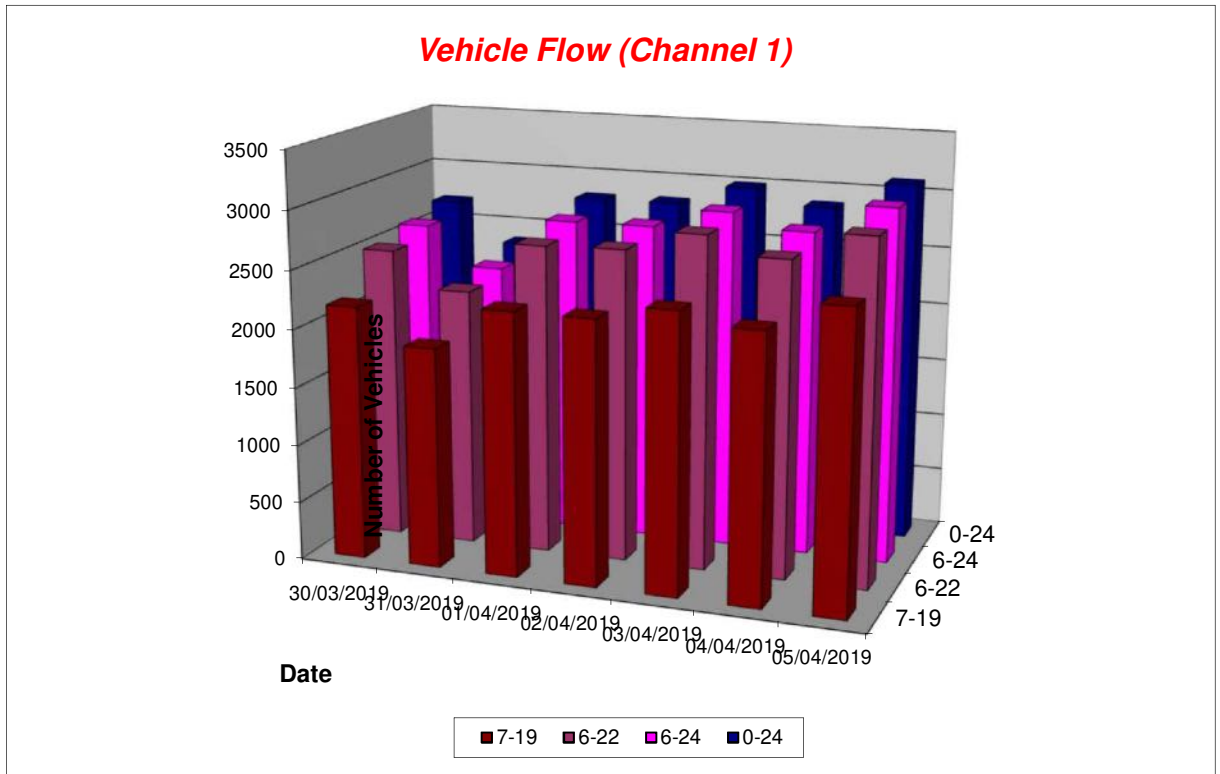

Warrington ATC F, Poplars Avenue

Produced by Road Data Services Ltd.

Channel 2 - Eastbound

Vehicle Flow

Week 1

Hr Ending	30/03/2019 Saturday	31/03/2019 Sunday	01/04/2019 Monday	02/04/2019 Tuesday	03/04/2019 Wednesday	04/04/2019 Thursday	05/04/2019 Friday	5 Day Ave	7 Day Ave
1	17	20	8	7	11	17	16	12	14
2	13	16	7	4	4	4	4	5	7
3	9	0	4	8	3	4	3	4	4
4	10	12	7	6	7	5	6	6	8
5	7	11	4	3	3	4	11	5	6
6	19	10	27	27	27	30	18	26	23
7	33	21	90	105	95	97	75	92	74
8	54	28	274	257	253	284	237	261	198
9	82	49	326	334	348	329	315	330	255
10	153	101	172	176	172	176	152	170	157
11	179	135	130	159	137	117	144	137	143
12	197	183	162	159	158	172	168	164	171
13	197	209	161	177	169	173	225	181	187
14	236	252	159	168	180	164	190	172	193
15	226	201	205	216	213	215	218	213	213
16	218	206	247	231	217	223	236	231	225
17	215	162	216	227	265	238	251	239	225
18	222	171	222	268	233	235	260	244	230
19	189	146	222	199	210	220	235	217	203
20	139	134	137	161	148	145	176	153	149
21	122	102	132	107	114	127	123	121	118
22	75	70	73	79	88	76	94	82	79
23	60	30	63	60	48	72	90	67	60
24	34	15	29	20	27	22	37	27	26
7-19	2168	1843	2496	2571	2555	2546	2631	2560	2401
6-22	2537	2170	2928	3023	3000	2991	3099	3008	2821
6-24	2631	2215	3020	3103	3075	3085	3226	3102	2908
0-24	2706	2284	3077	3158	3130	3149	3284	3160	2970

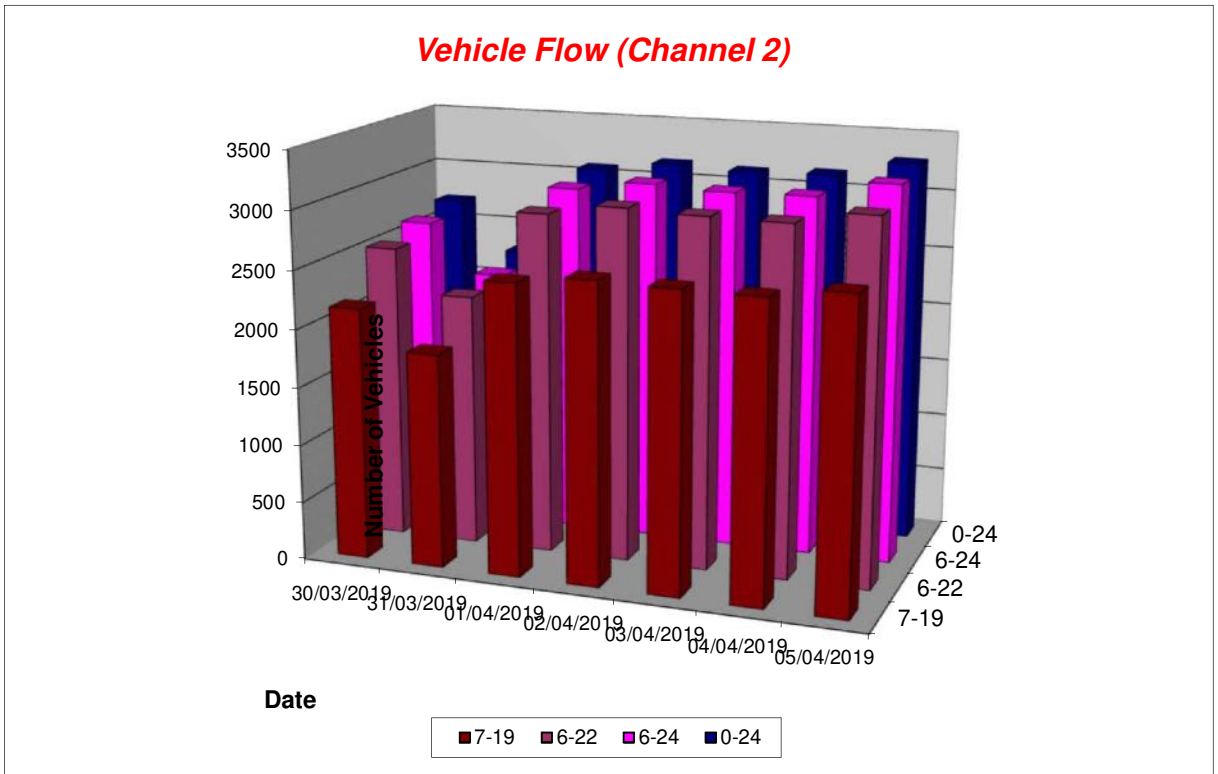

Poplars Avenue
Westbound

7 Day Average Westbound

Time	Total
0000	15
0100	7
0200	3
0300	6
0400	13
0500	35
0600	58
0700	111
0800	146
0900	149
1000	155
1100	172
1200	179
1300	199
1400	192
1500	227
1600	254
1700	268
1800	205
1900	149
2000	108
2100	80
2200	48
2300	28
07-19	2257
06-00	2728
00-00	2808

AAWT Factor 11.8469

5 Day Average Westbound

Time	Total
0000	13
0100	4
0200	2
0300	5
0400	12
0500	40
0600	69
0700	134
0800	171
0900	155
1000	151
1100	158
1200	158
1300	187
1400	179
1500	241
1600	284
1700	303
1800	225
1900	157
2000	111
2100	84
2200	51
2300	26
07-19	2345
06-00	2843
00-00	2919

AAWT Factor 11.9949

Poplars Avenue
Eastbound

7 Day Average Eastbound

Time	Total
0000	14
0100	7
0200	4
0300	8
0400	6
0500	23
0600	74
0700	198
0800	255
0900	157
1000	143
1100	171
1200	187
1300	193
1400	213
1500	225
1600	225
1700	230
1800	203
1900	149
2000	118
2100	79
2200	60
2300	26
07-19	2401
06-00	2908
00-00	2970

AAWT Factor 10.3474

5 Day Average Eastbound

Time	Total
0000	12
0100	5
0200	4
0300	6
0400	5
0500	26
0600	92
0700	261
0800	330
0900	170
1000	137
1100	164
1200	181
1300	172
1400	213
1500	231
1600	239
1700	244
1800	217
1900	153
2000	121
2100	82
2200	67
2300	27
07-19	2560
06-00	3102
00-00	3160

AAWT Factor 10.8077

Appendix 4

ATC Data – Blackbrook Avenue

Warrington ATC, Blackbrook Avenue

Produced by Road Data Services Ltd.

Channel 1 - Northbound

20/11/2015	Vehicle Classes													TOTAL
Hr Ending	1	2	3	4	5	6	7	8	9	10	11	12	13	
1	11	1	0	0	0	0	0	0	0	0	0	0	0	12
2	4	0	0	0	0	0	0	0	0	0	0	0	0	4
3	2	2	0	0	0	0	0	0	0	0	0	0	0	4
4	0	1	0	0	0	0	0	0	0	0	0	0	0	1
5	9	0	0	0	0	0	0	0	0	0	0	0	0	9
6	23	5	0	0	0	0	0	0	0	0	0	0	0	28
7	46	9	0	0	0	0	0	0	0	0	0	0	0	55
8	126	25	0	0	0	0	0	0	0	0	0	1	0	152
9	207	32	0	0	1	0	0	0	0	0	0	1	0	241
10	144	26	1	1	0	0	0	0	0	0	0	1	0	173
11	120	14	0	0	0	0	0	0	0	0	0	1	0	135
12	151	19	0	0	1	0	0	0	0	0	0	0	0	171
13	176	16	2	0	0	0	0	0	0	0	0	1	0	195
14	167	29	1	0	1	0	0	0	0	0	0	2	0	200
15	191	29	1	0	0	0	0	0	0	0	0	0	0	221
16	232	41	1	0	1	0	0	0	0	0	0	2	0	277
17	291	39	1	0	0	0	0	0	0	0	0	0	0	331
18	328	44	1	0	1	0	0	0	0	0	0	2	0	376
19	299	26	2	0	0	0	0	0	0	0	0	0	0	327
20	194	12	1	0	2	0	0	0	0	0	0	1	0	210
21	94	7	0	0	0	0	0	0	0	0	0	0	0	101
22	75	5	1	0	0	0	0	0	0	0	0	0	0	81
23	55	6	0	0	0	0	0	0	0	0	0	0	0	61
24	50	3	0	0	0	0	0	0	0	0	0	0	0	53
7-19	2432	340	10	1	5	0	0	0	0	0	0	11	0	2799
6-22	2841	373	12	1	7	0	0	0	0	0	0	12	0	3246
6-24	2946	382	12	1	7	0	0	0	0	0	0	12	0	3360
0-24	2995	391	12	1	7	0	0	0	0	0	0	12	0	3418

Channel 2 - Southbound

20/11/2015	Vehicle Classes													TOTAL
Hr Ending	1	2	3	4	5	6	7	8	9	10	11	12	13	
1	11	2	0	0	0	0	0	0	0	0	0	0	0	13
2	4	0	0	0	0	0	0	0	0	0	0	0	0	4
3	4	0	0	0	0	0	0	0	0	0	0	0	0	4
4	2	0	0	0	0	0	0	0	0	0	0	0	0	2
5	11	0	0	0	0	0	0	0	0	0	0	0	0	11
6	22	4	0	0	0	0	0	0	0	0	0	0	0	26
7	82	13	0	0	0	0	0	0	0	0	0	0	0	95
8	363	39	1	0	0	0	0	0	0	0	0	0	0	403
9	380	44	1	0	0	0	0	0	0	0	0	0	0	425
10	224	18	0	0	0	0	0	0	0	0	0	1	0	243
11	175	19	0	0	0	0	0	0	0	0	0	0	0	194
12	131	21	1	0	0	0	0	0	0	0	0	3	0	156
13	158	14	0	0	1	0	0	0	0	0	0	2	0	175
14	178	21	0	0	0	0	0	0	0	0	0	0	0	199
15	191	20	0	0	1	0	0	0	0	0	0	2	0	214
16	247	28	3	0	0	0	0	0	0	0	0	0	0	278
17	251	34	0	0	0	0	0	0	0	0	0	0	0	285
18	267	27	1	0	0	0	0	0	0	0	0	1	0	296
19	202	10	0	0	0	0	0	0	0	0	0	0	0	212
20	156	9	1	0	0	0	0	0	0	0	0	0	0	166
21	101	3	0	0	0	0	0	0	0	0	0	0	0	104
22	80	6	0	0	0	0	0	0	0	0	0	0	0	86
23	44	3	0	0	0	0	0	0	0	0	0	0	0	47
24	42	2	0	0	0	0	0	0	0	0	0	0	0	44
7-19	2767	295	7	0	2	0	0	0	0	0	0	9	0	3080
6-22	3186	326	8	0	2	0	0	0	0	0	0	9	0	3531
6-24	3272	331	8	0	2	0	0	0	0	0	0	9	0	3622
0-24	3326	337	8	0	2	0	0	0	0	0	0	9	0	3682

Warrington ATC, Blackbrook Avenue

Produced by Road Data Services Ltd.

Channel 1 - Northbound

21/11/2015	Vehicle Classes													TOTAL
Hr Ending	1	2	3	4	5	6	7	8	9	10	11	12	13	
1	26	1	0	0	0	0	0	0	0	0	0	0	0	27
2	8	0	0	0	0	0	0	0	0	0	0	0	0	8
3	7	0	0	0	0	0	0	0	0	0	0	0	0	7
4	6	1	0	0	0	0	0	0	0	0	0	0	0	7
5	5	0	0	0	0	0	0	0	0	0	0	0	0	5
6	8	1	0	0	0	0	0	0	0	0	0	0	0	9
7	17	1	0	0	0	0	0	0	0	0	0	0	0	18
8	35	4	0	0	0	0	0	0	0	0	0	0	0	39
9	54	9	1	0	0	0	0	0	0	0	0	0	0	64
10	103	13	1	0	0	0	0	0	0	0	0	1	0	118
11	162	26	0	0	0	0	0	0	0	0	0	0	0	188
12	218	17	0	0	0	0	0	0	0	0	0	0	0	235
13	198	30	0	0	0	0	0	1	0	0	0	0	0	229
14	186	14	0	0	0	0	0	1	0	0	0	1	0	202
15	181	23	0	0	0	0	0	0	0	0	0	0	0	204
16	192	18	1	0	0	0	0	0	0	0	0	1	0	212
17	187	11	0	0	0	0	0	0	0	0	0	0	0	198
18	185	9	0	0	0	0	0	0	0	0	0	0	0	194
19	147	10	0	0	0	0	0	0	0	0	0	0	0	157
20	102	7	0	0	0	0	0	0	0	0	0	0	0	109
21	84	8	0	0	0	0	0	0	0	0	0	0	0	92
22	60	1	0	0	0	0	0	0	0	0	0	0	0	61
23	55	1	0	0	0	0	0	0	0	0	0	0	0	56
24	52	5	1	0	0	0	0	0	0	0	0	0	0	58
7-19	1848	184	3	0	0	0	0	2	0	0	0	3	0	2040
6-22	2111	201	3	0	0	0	0	2	0	0	0	3	0	2320
6-24	2218	207	4	0	0	0	0	2	0	0	0	3	0	2434
0-24	2278	210	4	0	0	0	0	2	0	0	0	3	0	2497

Channel 2 - Southbound

21/11/2015	Vehicle Classes													TOTAL
Hr Ending	1	2	3	4	5	6	7	8	9	10	11	12	13	
1	21	1	0	0	0	0	0	0	0	0	0	0	0	22
2	13	1	0	0	0	0	0	0	0	0	0	0	0	14
3	4	1	0	0	0	0	0	0	0	0	0	0	0	5
4	3	0	0	0	0	0	0	0	0	0	0	0	0	3
5	4	0	0	0	0	0	0	0	0	0	0	0	0	4
6	10	2	0	0	0	0	0	0	0	0	0	0	0	12
7	29	4	0	0	0	0	0	0	0	0	0	0	0	33
8	51	3	0	0	0	0	0	0	0	0	0	0	0	54
9	120	14	0	0	0	0	0	0	0	0	0	0	0	134
10	166	17	0	0	1	0	0	0	0	0	0	0	0	184
11	199	14	0	0	0	0	0	0	0	0	0	0	0	213
12	206	12	0	0	0	0	0	0	0	0	0	0	0	218
13	187	8	0	0	0	0	0	0	0	0	0	0	0	195
14	191	10	0	1	0	0	0	1	0	0	0	0	0	203
15	206	14	0	0	0	0	0	0	0	0	0	0	0	220
16	178	12	0	0	0	0	0	0	0	0	0	0	0	190
17	189	12	0	0	0	0	0	0	1	0	0	0	0	202
18	161	8	0	0	0	0	0	0	0	0	0	0	0	169
19	112	1	0	0	0	0	0	0	0	0	0	0	0	113
20	123	4	0	0	0	0	0	0	0	0	0	0	0	127
21	81	4	0	0	0	0	0	0	0	0	0	0	0	85
22	64	1	0	0	0	0	0	0	0	0	0	0	0	65
23	54	0	0	0	0	0	0	0	0	0	0	0	0	54
24	49	3	0	0	0	0	0	0	0	0	0	0	0	52
7-19	1966	125	0	1	1	0	0	1	1	0	0	0	0	2095
6-22	2263	138	0	1	1	0	0	1	1	0	0	0	0	2405
6-24	2366	141	0	1	1	0	0	1	1	0	0	0	0	2511
0-24	2421	146	0	1	1	0	0	1	1	0	0	0	0	2571

Warrington ATC, Blackbrook Avenue

Produced by Road Data Services Ltd.

Channel 1 - Northbound

22/11/2015	Vehicle Classes													TOTAL
Hr Ending	1	2	3	4	5	6	7	8	9	10	11	12	13	
1	39	1	0	0	0	0	0	0	0	0	0	0	0	40
2	15	2	0	0	0	0	0	0	0	0	0	0	0	17
3	4	0	0	0	0	0	0	0	0	0	0	0	0	4
4	6	2	0	0	0	0	0	0	0	0	0	0	0	8
5	15	0	0	0	0	0	0	0	0	0	0	0	0	15
6	5	0	0	0	0	0	0	0	0	0	0	0	0	5
7	13	3	0	0	0	0	0	0	0	0	0	0	0	16
8	23	3	0	0	0	0	0	0	0	0	0	0	0	26
9	33	2	0	0	0	0	0	0	0	0	0	0	0	35
10	76	6	0	0	0	0	0	0	0	0	0	0	0	82
11	96	11	1	0	0	0	0	0	0	0	0	1	0	109
12	141	8	0	0	1	0	0	0	0	0	0	0	0	150
13	166	17	1	0	0	0	0	1	0	0	0	0	0	185
14	219	13	0	0	0	0	0	0	0	0	2	0	0	234
15	146	16	1	0	0	0	0	0	0	0	0	0	0	163
16	193	10	0	0	1	0	0	0	0	0	1	0	0	205
17	189	13	0	0	0	0	1	0	0	0	0	0	0	203
18	152	9	0	0	0	0	0	0	0	0	1	0	0	162
19	108	4	2	0	1	0	0	0	1	0	0	0	0	116
20	102	5	0	0	0	0	0	0	0	0	0	0	0	107
21	68	2	0	0	0	0	0	0	0	0	0	0	0	70
22	48	2	0	0	0	0	0	0	0	0	0	0	0	50
23	36	4	0	0	0	0	0	0	0	0	0	0	0	40
24	14	3	0	0	0	0	0	0	0	0	0	0	0	17
7-19	1542	112	5	0	3	0	1	1	1	0	0	5	0	1670
6-22	1773	124	5	0	3	0	1	1	1	0	0	5	0	1913
6-24	1823	131	5	0	3	0	1	1	1	0	0	5	0	1970
0-24	1907	136	5	0	3	0	1	1	1	0	0	5	0	2059

Channel 2 - Southbound

22/11/2015	Vehicle Classes													TOTAL
Hr Ending	1	2	3	4	5	6	7	8	9	10	11	12	13	
1	40	1	0	0	0	0	0	0	0	0	0	0	0	41
2	16	5	0	0	0	0	0	0	0	0	0	0	0	21
3	5	1	0	0	0	0	0	0	0	0	0	0	0	6
4	6	4	0	0	0	0	0	0	0	0	0	0	0	10
5	13	0	0	0	0	0	0	0	0	0	0	0	0	13
6	10	0	0	0	0	0	0	0	0	0	0	0	0	10
7	14	2	0	0	0	0	0	0	0	0	0	0	0	16
8	27	2	0	0	0	0	0	0	0	0	0	0	0	29
9	55	2	0	0	0	0	0	0	0	0	0	0	0	57
10	85	2	1	0	0	0	0	0	0	0	0	0	0	88
11	125	10	0	0	0	0	0	0	0	0	2	0	0	137
12	162	14	0	0	0	0	0	0	0	0	0	0	0	176
13	200	12	1	0	0	0	0	0	0	0	1	0	0	214
14	204	15	0	1	2	0	0	0	0	0	0	0	0	222
15	186	16	0	0	0	0	0	0	0	0	1	0	0	203
16	160	6	0	0	0	0	0	0	0	0	0	0	0	166
17	194	8	0	0	0	0	0	0	0	0	1	0	0	203
18	120	10	0	0	0	0	0	0	0	0	0	0	0	130
19	118	3	0	0	0	0	0	0	0	0	0	0	0	121
20	85	1	0	0	0	0	0	0	0	0	1	0	0	87
21	74	4	0	0	0	0	0	0	0	0	0	0	0	78
22	52	2	0	0	0	0	0	0	0	0	0	0	0	54
23	27	3	0	0	0	0	0	0	0	0	0	0	0	30
24	20	1	0	0	0	0	0	0	0	0	0	0	0	21
7-19	1636	100	2	1	2	0	0	0	0	0	5	0	0	1746
6-22	1861	109	2	1	2	0	0	0	0	0	6	0	0	1981
6-24	1908	113	2	1	2	0	0	0	0	0	6	0	0	2032
0-24	1998	124	2	1	2	0	0	0	0	0	6	0	0	2133

Warrington ATC, Blackbrook Avenue

Produced by Road Data Services Ltd.

Channel 1 - Northbound

23/11/2015	Vehicle Classes													TOTAL
Hr Ending	1	2	3	4	5	6	7	8	9	10	11	12	13	
1	3	4	0	0	0	0	0	0	0	0	0	0	0	7
2	2	2	0	0	0	0	0	0	0	0	0	0	0	4
3	2	0	0	0	0	0	0	0	0	0	0	0	0	2
4	2	1	0	0	0	0	0	0	0	0	0	0	0	3
5	6	0	0	0	0	0	0	0	0	0	0	0	0	6
6	27	2	0	0	0	0	0	0	0	0	0	1	0	30
7	36	3	0	0	0	0	0	0	0	0	0	1	0	40
8	135	28	0	0	0	0	0	0	0	0	0	1	0	164
9	214	29	1	0	1	0	0	0	0	0	0	1	0	246
10	109	24	1	0	0	0	0	0	1	0	0	0	0	135
11	101	16	0	0	0	0	0	0	0	0	0	1	0	118
12	127	16	0	0	0	0	0	0	0	0	0	1	0	144
13	149	17	0	0	0	0	0	0	0	0	0	0	0	166
14	122	23	0	0	1	0	0	0	0	0	0	1	0	147
15	143	25	0	0	0	0	0	0	0	0	0	0	0	168
16	264	33	0	0	1	0	0	0	0	0	0	0	0	298
17	268	48	0	0	0	0	0	0	1	0	0	0	0	317
18	259	31	2	0	0	0	0	0	1	0	0	2	0	295
19	198	18	0	0	0	0	0	0	0	0	0	0	0	216
20	122	8	0	0	0	0	0	0	0	0	0	0	0	130
21	94	8	0	0	0	0	0	0	0	0	0	0	0	102
22	64	2	0	0	0	0	0	0	0	0	0	0	0	66
23	46	5	0	0	0	0	0	0	0	0	0	0	0	51
24	13	0	0	0	0	0	0	0	0	0	0	0	0	13
7-19	2089	308	4	0	3	0	0	0	3	0	0	7	0	2414
6-22	2405	329	4	0	3	0	0	0	3	0	0	8	0	2752
6-24	2464	334	4	0	3	0	0	0	3	0	0	8	0	2816
0-24	2506	343	4	0	3	0	0	0	3	0	0	9	0	2868

Channel 2 - Southbound

23/11/2015	Vehicle Classes													TOTAL
Hr Ending	1	2	3	4	5	6	7	8	9	10	11	12	13	
1	5	1	0	0	0	0	0	0	0	0	0	0	0	6
2	2	0	0	0	0	0	0	0	0	0	0	0	0	2
3	2	0	0	0	0	0	0	0	0	0	0	0	0	2
4	1	0	0	0	0	0	0	0	0	0	0	0	0	1
5	4	1	0	0	0	0	0	0	0	0	0	0	0	5
6	22	3	0	0	0	0	0	0	0	0	0	1	0	26
7	80	13	0	0	0	0	0	0	0	0	0	0	0	93
8	353	46	2	0	2	0	0	0	0	0	0	0	0	403
9	438	34	2	1	1	0	0	0	0	0	0	1	0	477
10	247	32	1	0	0	0	0	1	2	0	0	0	0	283
11	157	16	0	0	0	0	0	0	0	0	0	0	0	173
12	150	22	0	1	0	0	0	0	0	0	0	3	0	176
13	155	14	0	0	0	0	0	0	0	0	0	2	0	171
14	196	26	1	0	0	0	0	0	1	0	0	0	0	224
15	196	29	1	0	0	0	0	1	1	0	0	1	0	229
16	180	17	1	0	0	0	0	0	0	0	0	0	0	198
17	231	36	0	0	0	0	0	0	0	0	0	1	0	268
18	272	23	2	0	0	0	0	0	0	0	0	1	0	298
19	188	12	0	0	0	0	0	0	0	0	0	0	0	200
20	134	2	0	0	0	0	0	0	0	0	0	0	0	136
21	80	7	0	0	0	0	0	0	0	0	0	0	0	87
22	59	2	0	0	0	0	0	0	0	0	0	0	0	61
23	35	6	0	0	0	0	0	0	0	0	0	0	0	41
24	15	1	0	0	0	0	0	0	0	0	0	0	0	16
7-19	2763	307	10	2	3	0	0	2	4	0	0	9	0	3100
6-22	3116	331	10	2	3	0	0	2	4	0	0	9	0	3477
6-24	3166	338	10	2	3	0	0	2	4	0	0	9	0	3534
0-24	3202	343	10	2	3	0	0	2	4	0	0	10	0	3576

Warrington ATC, Blackbrook Avenue

Produced by Road Data Services Ltd.

Channel 1 - Northbound

24/11/2015	Vehicle Classes													TOTAL
Hr Ending	1	2	3	4	5	6	7	8	9	10	11	12	13	
1	8	2	0	0	0	0	0	0	0	0	0	0	0	10
2	1	0	0	0	0	0	0	0	0	0	0	0	0	1
3	0	0	0	0	0	0	0	0	0	0	0	0	0	0
4	3	1	0	0	0	0	0	0	0	0	0	0	0	4
5	6	1	0	0	0	0	0	0	0	0	0	0	0	7
6	24	3	0	0	0	0	0	0	0	0	0	0	0	27
7	45	11	2	0	0	0	0	1	0	0	0	1	0	60
8	133	26	1	0	0	0	0	0	0	0	0	1	0	161
9	213	21	1	0	1	0	0	0	0	0	0	1	0	237
10	120	22	2	0	0	0	0	1	0	0	2	1	0	148
11	107	18	2	0	1	0	0	0	0	0	0	1	0	129
12	118	14	0	0	0	0	0	0	0	0	0	2	0	134
13	156	19	0	0	1	0	0	0	0	0	0	0	0	176
14	122	18	1	0	0	0	1	0	0	0	0	1	0	143
15	148	24	0	0	2	0	0	0	1	0	0	0	0	175
16	201	31	0	0	2	0	1	1	0	0	0	0	0	236
17	269	48	1	0	0	0	0	0	0	0	0	1	0	319
18	296	32	1	0	0	0	0	0	0	0	0	0	0	329
19	225	20	1	0	0	0	0	0	0	0	0	0	0	246
20	147	15	0	0	1	0	0	0	0	0	0	1	0	164
21	96	18	0	0	0	0	0	0	1	0	0	1	0	116
22	101	5	0	0	0	0	0	0	0	0	0	0	0	106
23	47	6	0	0	0	0	0	0	0	0	0	0	0	53
24	30	2	0	0	0	0	0	0	0	0	0	0	0	32
7-19	2108	293	10	0	7	0	2	2	1	0	2	8	0	2433
6-22	2497	342	12	0	8	0	2	3	2	0	2	11	0	2879
6-24	2574	350	12	0	8	0	2	3	2	0	2	11	0	2964
0-24	2616	357	12	0	8	0	2	3	2	0	2	11	0	3013

Channel 2 - Southbound

24/11/2015	Vehicle Classes													TOTAL
Hr Ending	1	2	3	4	5	6	7	8	9	10	11	12	13	
1	9	1	0	0	0	0	0	0	0	0	0	0	0	10
2	6	0	0	0	0	0	0	0	0	0	0	0	0	6
3	0	0	0	0	0	0	0	0	0	0	0	0	0	0
4	7	0	0	0	0	0	0	0	0	0	0	0	0	7
5	6	0	0	0	0	0	0	0	0	0	0	0	0	6
6	17	6	0	0	0	0	0	0	0	0	0	1	0	24
7	88	10	0	0	0	0	0	0	0	0	0	0	0	98
8	355	33	1	1	1	0	0	0	0	0	0	0	0	391
9	492	52	1	0	0	0	0	0	0	0	0	2	0	547
10	265	31	1	0	0	0	0	0	0	0	0	1	0	298
11	157	10	1	0	0	0	0	1	0	0	1	0	0	170
12	146	12	1	0	0	0	0	0	0	0	0	0	0	159
13	146	15	1	0	0	0	0	0	0	0	0	1	0	163
14	148	16	0	1	1	0	0	0	0	0	0	1	0	167
15	168	22	1	0	1	0	0	0	0	0	0	1	0	193
16	197	20	4	0	1	0	0	0	0	0	0	0	0	222
17	221	28	3	0	0	0	0	0	0	0	0	0	0	252
18	274	26	1	0	0	0	0	0	0	0	0	1	0	302
19	213	14	0	0	0	0	0	0	0	0	0	0	0	227
20	136	10	0	0	0	0	0	0	0	0	0	0	0	146
21	89	18	1	0	0	0	0	0	0	0	0	0	0	108
22	72	2	0	0	0	0	0	0	0	0	0	0	0	74
23	42	4	0	0	0	0	0	0	0	0	0	0	0	46
24	33	1	0	0	0	0	0	0	0	0	0	0	0	34
7-19	2782	279	15	2	4	0	0	1	0	0	1	7	0	3091
6-22	3167	319	16	2	4	0	0	1	0	0	1	7	0	3517
6-24	3242	324	16	2	4	0	0	1	0	0	1	7	0	3597
0-24	3287	331	16	2	4	0	0	1	0	0	1	8	0	3650

Warrington ATC, Blackbrook Avenue

Produced by Road Data Services Ltd.

Channel 1 - Northbound

25/11/2015	Vehicle Classes													TOTAL
Hr Ending	1	2	3	4	5	6	7	8	9	10	11	12	13	
1	6	3	0	0	0	0	0	0	0	0	0	0	0	9
2	0	0	0	0	0	0	0	0	0	0	0	0	0	0
3	2	0	0	0	0	0	0	0	0	0	0	0	0	2
4	1	0	0	0	0	0	0	0	0	0	0	0	0	1
5	6	0	0	0	0	0	0	0	0	0	0	0	0	6
6	22	4	0	0	0	0	0	0	0	0	0	0	0	26
7	48	11	0	0	0	0	0	0	0	0	0	0	0	59
8	144	20	0	0	0	0	0	0	0	0	0	2	0	166
9	217	33	2	0	0	0	0	0	0	1	0	1	0	254
10	116	22	1	0	1	0	0	0	0	0	0	0	0	140
11	122	17	0	0	1	0	0	0	0	0	0	1	0	141
12	145	12	0	0	0	0	0	0	0	0	0	1	0	158
13	153	17	0	0	0	0	0	0	0	0	0	1	0	171
14	116	22	1	0	1	0	0	0	0	0	0	2	0	142
15	151	33	0	0	0	0	0	0	0	0	0	2	0	186
16	229	30	1	0	0	0	0	0	0	0	0	0	0	260
17	268	54	1	0	2	0	0	0	0	0	0	1	0	326
18	309	34	0	0	0	0	0	0	0	0	0	2	0	345
19	200	23	0	0	0	0	0	0	0	0	0	0	0	223
20	153	15	1	0	0	0	0	0	0	0	0	0	0	169
21	91	9	0	0	0	0	0	0	0	0	0	0	0	100
22	85	12	0	0	0	0	0	0	0	0	0	0	0	97
23	69	3	0	0	0	0	0	0	0	0	0	0	0	72
24	20	0	0	0	0	0	0	0	0	0	0	0	0	20
7-19	2170	317	6	0	5	0	0	0	0	1	0	13	0	2512
6-22	2547	364	7	0	5	0	0	0	0	1	0	13	0	2937
6-24	2636	367	7	0	5	0	0	0	0	1	0	13	0	3029
0-24	2673	374	7	0	5	0	0	0	0	1	0	13	0	3073

Channel 2 - Southbound

25/11/2015	Vehicle Classes													TOTAL
Hr Ending	1	2	3	4	5	6	7	8	9	10	11	12	13	
1	8	3	0	0	0	0	0	0	0	0	0	0	0	11
2	1	1	0	0	0	0	0	0	0	0	0	0	0	2
3	0	0	0	0	0	0	0	0	0	0	0	0	0	0
4	2	0	0	0	0	0	0	0	0	0	0	0	0	2
5	5	0	0	0	0	0	0	0	0	0	0	0	0	5
6	24	4	0	0	0	0	0	0	0	0	0	0	0	28
7	97	13	0	0	0	0	1	0	0	0	0	0	0	111
8	375	45	1	0	0	0	0	0	0	0	0	1	0	422
9	458	51	4	0	1	0	0	0	0	0	0	1	0	515
10	224	23	0	0	0	0	0	0	0	0	0	4	0	251
11	149	22	0	0	1	0	0	0	0	0	0	0	0	172
12	131	10	2	0	0	0	0	0	0	0	0	1	0	144
13	154	16	0	0	1	0	0	0	0	0	0	1	0	172
14	182	18	1	0	0	0	0	0	0	0	0	0	0	201
15	176	23	0	0	0	0	0	0	0	0	0	0	0	199
16	204	26	1	0	0	0	0	0	0	0	0	0	0	231
17	218	41	3	1	0	0	0	0	0	0	0	2	0	265
18	248	28	0	0	0	0	0	0	0	0	0	0	0	276
19	219	22	0	0	0	0	0	0	0	0	0	0	0	241
20	164	15	0	1	0	0	0	0	0	0	0	0	0	180
21	90	6	0	0	0	0	0	0	0	0	0	0	0	96
22	64	4	0	0	0	0	0	0	0	0	0	0	0	68
23	52	1	0	0	0	0	0	0	0	0	0	0	0	53
24	20	2	0	0	0	0	0	0	0	0	0	0	0	22
7-19	2738	325	12	1	3	0	0	0	0	0	0	10	0	3089
6-22	3153	363	12	2	3	0	1	0	0	0	0	10	0	3544
6-24	3225	366	12	2	3	0	1	0	0	0	0	10	0	3619
0-24	3265	374	12	2	3	0	1	0	0	0	0	10	0	3667

Warrington ATC, Blackbrook Avenue

Produced by Road Data Services Ltd.

Channel 1 - Northbound

26/11/2015	Vehicle Classes													TOTAL
Hr Ending	1	2	3	4	5	6	7	8	9	10	11	12	13	
1	5	2	0	0	0	0	0	0	0	0	0	0	0	7
2	0	0	0	0	0	0	0	0	0	0	0	0	0	0
3	2	1	0	0	0	0	0	0	0	0	0	0	0	3
4	1	0	0	0	0	0	0	0	0	0	0	0	0	1
5	6	0	0	0	0	0	0	0	0	0	0	0	0	6
6	20	3	0	0	0	0	0	0	0	0	0	0	0	23
7	48	7	0	0	0	0	0	0	0	0	0	0	0	55
8	128	26	1	0	0	0	0	0	0	0	0	0	0	155
9	228	18	1	0	1	0	0	0	0	0	0	1	0	249
10	112	18	2	0	0	0	0	1	0	0	3	1	0	137
11	118	13	0	0	1	0	0	0	0	0	0	0	0	132
12	137	18	0	0	1	0	0	1	0	0	0	1	0	158
13	155	12	1	0	0	0	0	0	0	0	0	0	0	168
14	139	20	1	1	0	0	0	0	0	0	0	0	0	161
15	165	27	1	0	0	0	0	0	0	0	0	0	0	193
16	211	30	1	0	1	0	0	0	0	0	0	0	0	243
17	315	44	0	0	1	0	0	0	0	0	0	0	0	360
18	298	29	0	0	0	0	1	0	0	0	0	1	0	329
19	234	23	0	0	2	0	0	0	0	0	0	0	0	259
20	160	8	1	0	0	0	0	0	0	0	0	0	0	169
21	128	7	0	0	0	0	0	0	0	0	0	1	0	136
22	95	6	1	0	0	0	0	0	0	0	0	0	0	102
23	60	3	0	0	0	0	0	0	0	0	0	0	0	63
24	29	2	0	0	0	0	0	0	0	0	0	0	0	31
7-19	2240	278	8	1	7	0	1	2	0	0	3	4	0	2544
6-22	2671	306	10	1	7	0	1	2	0	0	3	5	0	3006
6-24	2760	311	10	1	7	0	1	2	0	0	3	5	0	3100
0-24	2794	317	10	1	7	0	1	2	0	0	3	5	0	3140

Channel 2 - Southbound

26/11/2015	Vehicle Classes													TOTAL
Hr Ending	1	2	3	4	5	6	7	8	9	10	11	12	13	
1	5	2	0	0	0	0	0	0	0	0	0	0	0	7
2	1	0	0	0	0	0	0	0	0	0	0	0	0	1
3	2	0	0	0	0	0	0	0	0	0	0	0	0	2
4	1	0	0	0	0	0	0	0	0	0	0	0	0	1
5	5	0	0	0	0	0	0	0	0	0	0	0	0	5
6	23	4	0	0	0	0	0	0	0	0	0	0	0	27
7	94	6	0	0	0	0	0	0	0	0	0	0	0	100
8	353	47	2	0	1	0	0	0	0	0	0	0	0	403
9	465	46	1	0	1	0	0	0	1	0	0	2	0	516
10	257	37	1	0	0	0	0	0	0	0	0	1	0	296
11	138	19	0	0	0	0	0	0	0	0	0	1	0	158
12	161	15	1	0	0	0	0	0	0	0	0	0	0	177
13	152	9	0	0	0	0	0	0	0	0	0	2	0	163
14	168	13	1	0	1	0	0	0	0	0	0	0	0	183
15	203	18	0	0	0	0	0	0	0	0	0	0	0	221
16	208	20	0	0	1	0	0	0	0	0	0	0	0	229
17	243	30	2	0	1	0	0	0	0	0	0	0	0	276
18	296	22	0	0	0	0	0	0	0	0	0	0	0	318
19	209	18	0	0	0	0	0	0	0	0	0	1	0	228
20	169	7	1	0	0	0	0	0	0	0	0	0	0	177
21	111	7	1	0	0	0	0	0	0	0	0	0	0	119
22	78	3	0	0	0	0	0	0	0	0	0	0	0	81
23	40	0	0	0	0	0	0	0	0	0	0	0	0	40
24	50	2	0	0	0	0	0	0	0	0	0	0	0	52
7-19	2853	294	8	0	5	0	0	0	1	0	0	7	0	3168
6-22	3305	317	10	0	5	0	0	0	1	0	0	7	0	3645
6-24	3395	319	10	0	5	0	0	0	1	0	0	7	0	3737
0-24	3432	325	10	0	5	0	0	0	1	0	0	7	0	3780

Blackbrook Avenue
Northbound

7 Day Average Northbound

Time	Total
0000	16
0100	5
0200	3
0300	4
0400	8
0500	21
0600	43
0700	123
0800	189
0900	133
1000	136
1100	164
1200	184
1300	176
1400	187
1500	247
1600	293
1700	290
1800	221
1900	151
2000	102
2100	80
2200	57
2300	32
07-19	2345
06-00	2810
00-00	2867

AAWT Factor 9.8823

5 Day Average Northbound

Time	Total
0000	9
0100	2
0200	2
0300	2
0400	7
0500	27
0600	54
0700	160
0800	245
0900	147
1000	131
1100	153
1200	175
1300	159
1400	189
1500	263
1600	331
1700	335
1800	254
1900	168
2000	111
2100	90
2200	60
2300	30
07-19	2540
06-00	3054
00-00	3102

AAWT Factor 10.5267

Blackbrook Avenue
Southbound

7 Day Average Southbound

Time	Total
0000	16
0100	7
0200	3
0300	4
0400	7
0500	22
0600	78
0700	301
0800	382
0900	235
1000	174
1100	172
1200	179
1300	200
1400	211
1500	216
1600	250
1700	256
1800	192
1900	146
2000	97
2100	70
2200	44
2300	34
07-19	2767
06-00	3236
00-00	3294

AAWT Factor 8.2976

5 Day Average Southbound

Time	Total
0000	9
0100	3
0200	2
0300	3
0400	6
0500	26
0600	99
0700	404
0800	496
0900	274
1000	173
1100	162
1200	169
1300	195
1400	211
1500	232
1600	269
1700	298
1800	222
1900	161
2000	103
2100	74
2200	45
2300	34
07-19	3106
06-00	3622
00-00	3671

AAWT Factor 9.1229

Appendix 5

ATC Data – Delph Lane

Warrington ATC A, Delph Road

Produced by Road Data Services Ltd.

Channel 1 - Northbound

Vehicle Flow

Week 1

Hr Ending	30/03/2019 Saturday	31/03/2019 Sunday	01/04/2019 Monday	02/04/2019 Tuesday	03/04/2019 Wednesday	04/04/2019 Thursday	05/04/2019 Friday	5 Day Ave	7 Day Ave
1	25	17	6	5	4	4	6	5	10
2	8	6	6	4	2	4	2	4	5
3	7	0	0	0	3	1	3	1	2
4	6	7	2	4	10	3	4	5	5
5	8	5	14	10	9	8	13	11	10
6	25	18	44	59	61	50	49	53	44
7	30	23	112	123	120	116	112	117	91
8	72	35	255	274	301	308	260	280	215
9	106	62	332	406	368	351	297	351	275
10	176	131	152	177	171	179	178	171	166
11	244	155	140	136	144	155	147	144	160
12	243	193	156	145	167	157	193	164	179
13	223	216	193	183	146	142	185	170	184
14	236	248	170	187	176	198	207	188	203
15	227	238	233	257	204	203	305	240	238
16	191	185	215	272	294	277	362	284	257
17	180	194	394	467	435	472	478	449	374
18	192	128	449	465	455	582	447	480	388
19	145	125	209	230	250	293	247	246	214
20	100	99	147	128	150	142	145	142	130
21	67	78	96	101	116	116	76	101	93
22	61	48	77	62	74	68	67	70	65
23	44	36	48	58	49	56	52	53	49
24	34	13	8	8	15	18	23	14	17
7-19	2235	1910	2898	3199	3111	3317	3306	3166	2854
6-22	2493	2158	3330	3613	3571	3759	3706	3596	3233
6-24	2571	2207	3386	3679	3635	3833	3781	3663	3299
0-24	2650	2260	3458	3761	3724	3903	3858	3741	3373

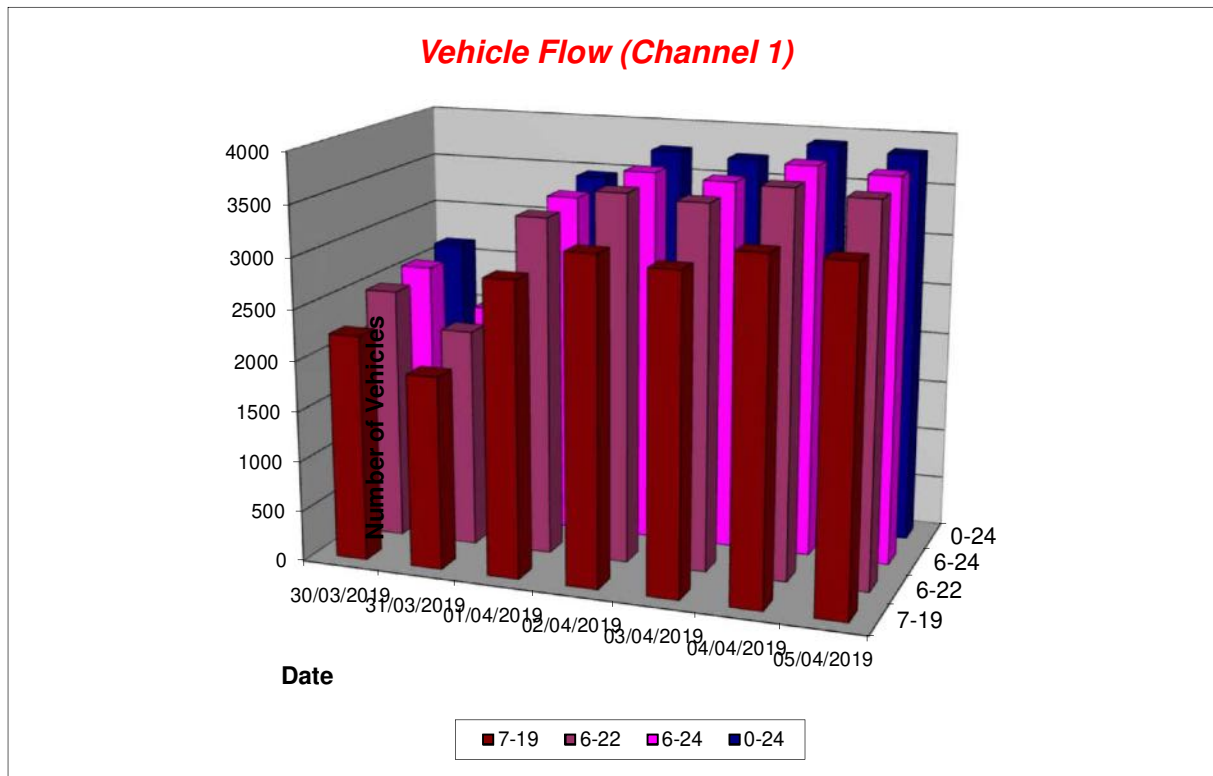

Warrington ATC A, Delph Road

Produced by Road Data Services Ltd.

Channel 2 - Southbound

Vehicle Flow

Week 1

Hr Ending	30/03/2019 Saturday	31/03/2019 Sunday	01/04/2019 Monday	02/04/2019 Tuesday	03/04/2019 Wednesday	04/04/2019 Thursday	05/04/2019 Friday	5 Day Ave	7 Day Ave
1	30	26	6	8	7	6	9	7	13
2	13	12	5	4	3	5	8	5	7
3	6	0	3	6	4	8	1	4	4
4	10	10	4	3	2	0	2	2	4
5	11	12	8	10	20	10	13	12	12
6	21	17	63	65	51	58	47	57	46
7	33	13	172	200	196	184	183	187	140
8	66	28	432	404	455	438	398	425	317
9	98	52	477	574	554	490	404	500	378
10	167	92	262	346	375	240	243	293	246
11	216	153	149	174	193	156	171	169	173
12	259	204	154	164	166	159	297	188	200
13	263	252	174	183	169	165	216	181	203
14	254	263	142	190	189	182	241	189	209
15	237	246	207	187	196	198	250	208	217
16	214	233	258	243	273	231	305	262	251
17	235	210	378	338	309	348	322	339	306
18	232	169	346	368	401	362	312	358	313
19	155	140	221	221	234	228	222	225	203
20	110	141	129	149	183	152	130	149	142
21	64	111	100	99	126	84	87	99	96
22	48	61	73	71	81	66	77	74	68
23	51	48	45	76	54	43	70	58	55
24	54	18	20	22	18	41	42	29	31
7-19	2396	2042	3200	3392	3514	3197	3381	3337	3017
6-22	2651	2368	3674	3911	4100	3683	3858	3845	3464
6-24	2756	2434	3739	4009	4172	3767	3970	3931	3550
0-24	2847	2511	3828	4105	4259	3854	4050	4019	3636

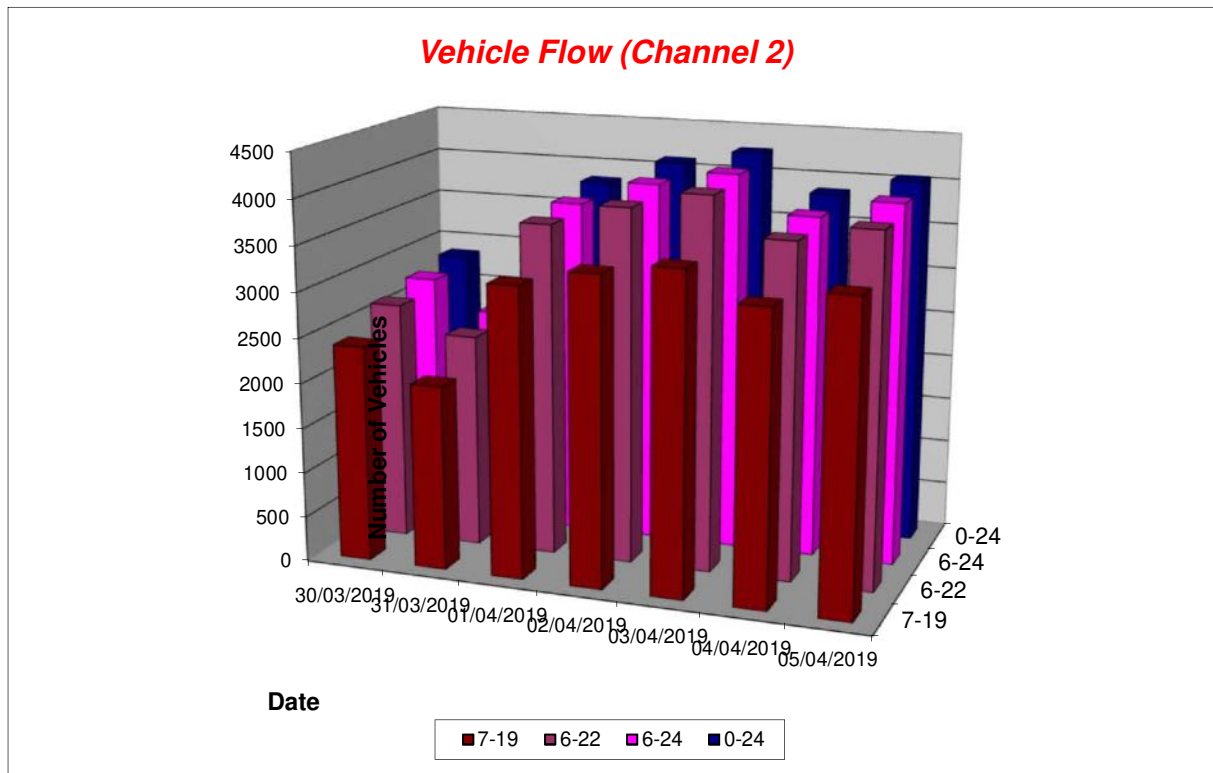

Delph Lane
Northbound

7 Day Average Northbound

Time	Total
0000	10
0100	5
0200	2
0300	5
0400	10
0500	44
0600	91
0700	215
0800	275
0900	166
1000	160
1100	179
1200	184
1300	203
1400	238
1500	257
1600	374
1700	388
1800	214
1900	130
2000	93
2100	65
2200	49
2300	17
07-19	2854
06-00	3299
00-00	3373

AAWT Factor 8.1248

5 Day Average Northbound

Time	Total
0000	5
0100	4
0200	1
0300	5
0400	11
0500	53
0600	117
0700	280
0800	351
0900	171
1000	144
1100	164
1200	170
1300	188
1400	240
1500	284
1600	449
1700	480
1800	246
1900	142
2000	101
2100	70
2200	53
2300	14
07-19	3166
06-00	3663
00-00	3741

AAWT Factor 8.8218

Delph Lane
Southbound

7 Day Average Southbound

Time	Total
0000	13
0100	7
0200	4
0300	4
0400	12
0500	46
0600	140
0700	317
0800	378
0900	246
1000	173
1100	200
1200	203
1300	209
1400	217
1500	251
1600	306
1700	313
1800	203
1900	142
2000	96
2100	68
2200	55
2300	31
07-19	3017
06-00	3550
00-00	3636

AAWT Factor 8.4801

5 Day Average Southbound

Time	Total
0000	7
0100	5
0200	4
0300	2
0400	12
0500	57
0600	187
0700	425
0800	500
0900	293
1000	169
1100	188
1200	181
1300	189
1400	208
1500	262
1600	339
1700	358
1800	225
1900	149
2000	99
2100	74
2200	58
2300	29
07-19	3337
06-00	3931
00-00	4019

AAWT Factor 9.1684

TECHNICAL NOTE

PROJECT: Peel Hall, Warrington

REPORT: 1901/TN/09 – Link Capacity

DATE: January 2020

1. This Technical Note (TN/09) has been prepared by Highgate Transportation Ltd to help quantify and explain the implications of increased traffic flows on the residential area to the immediate south of the Peel Hall development in terms of impact on link capacity. In particular this Technical Note considers whether or not the development traffic results in a harmful change to where any given road sits within the local road hierarchy, further to the Inspector's comments {IR13.45-13.54} regarding possible impact on the character of the local area.
2. This Technical Note should be read in conjunction with Technical Note (TN/10), which considers parking and traffic calming measures in the area to the south of the Peel Hall site, including highway safety in general and pedestrian safety in particular. This is in order to address the Inspector's comment {IR13.50} that development traffic within this area would result in conditions that would be busier, noisier and potentially make it more difficult for pedestrians to cross.
3. This report is structured to show a comparison with the 2022 Do Minimum (no Peel Hall development) traffic flows from the Peel Hall WMMTM16 SATURN modelling and the forecast 2032 Do Minimum and 2032 Do Something (full Peel Hall development) traffic flows at different locations on the area to the south, as identified by the Inspector {IR13.49}. These links are Poplars Avenue, Capesthorpe Road, Cleveland Road, Cotswold Road, Howson Road and Sandy Lane. We have also identified Statham Avenue, Greenwood Crescent and Sandy Lane West.

Traffic Flows

4. **Table 1** shows two-way traffic flows on those road links within the study area listed in **paragraph 2** during both the AM Peak hour (0800-0900) and PM Peak hour (1700-1800) periods, as well as daily flows (AADT24) for a 2022 (year of opening) Do Minimum scenario. AADT24 data is based on a methodology and factors agreed with the Council, and Highways England (see correspondence contained in **Appendix 1**).

Table 1 – Link flows within the study area (2022 Do Minimum)

Link Name	AM Peak Hour	PM Peak Hour	AADT_24
	2022 DM	2022 DM	2022 DM
Capesthorne Road (Greenwood Crescent to Blackbrook Avenue)	848	782	7309
Capesthorne Road (Poplars Ave - parallel to Humber Road)	496	617	4991
Cleveland Road	316	375	3801
Cotswold Road	40	36	418
Howson Road	43	39	451
Greenwood Crescent (Darley Ave to Grasmere Ave)	297	9	1683
Greenwood Crescent (Grasmere Ave to Meteor Cres)	482	84	3114
Poplars Avenue - East of (Central) Site entrance	383	440	4528
Poplars Avenue (Greenwood Cres - Capesthorne Road)	758	1042	9902
Poplars Avenue (south of Capesthorne Road)	740	685	7839
Sandy Lane West	578	774	7438
Sandy Lane	330	493	4528
Statham Avenue	353	431	4313

5. **Tables 2 and 3** set out the two-way traffic flows on the road links during the AM Peak hour (0800-0900) and PM Peak hour (1700-1800) for 2032 Do Minimum and Do Something respectively. The 'Flow 1' and 'Flow 2' columns are the forecast flows in each direction on the respective link.

Table 2 – Link flows within the study area (2032 Do Minimum and 2032 Do Something) AM Peak Hour

Link Name	AM Peak Hour						
	2032 DM (Flow 1)	2032 DM (Flow 2)	2032 DM (Two-Way)	2032 DS (full) (Flow 1)	2032 DS (full) (Flow 2)	2032 DS (full) Two-Way	2032 DS (full)-2032 DM Two-Way
Capesthorne Road (Greenwood Crescent to Blackbrook Avenue)	580	443	1023	800	686	1486	463
Capesthorne Road (Poplars Ave - parallel to Humber Road)	443	261	704	648	399	1047	343
Cleveland Road	244	286	530	299	341	640	110
Cotswold Road	13	30	43	46	40	86	43
Howson Road	26	22	48	44	23	67	19
Greenwood Crescent (Darley Ave to Grasmere Ave)	129	181	310	135	264	399	89
Greenwood Crescent (Grasmere Ave to Meteor Cres)	242	269	511	212	350	562	51
Poplars Avenue - East of (Central) Site entrance	398	208	606	564	300	864	258
Poplars Avenue (Greenwood Cres - Capesthorne Road)	575	489	1064	680	628	1308	244
Poplars Avenue (south of Capesthorne Road)	454	416	870	508	556	1064	194
Sandy Lane West	418	510	928	503	562	1065	137
Sandy Lane	274	201	475	276	213	489	14
Statham Avenue	299	118	417	401	108	509	92

Table 3 – Link flows within the study area (2032 Do Minimum and 2032 Do Something) PM Peak Hour

Link Name	PM Peak Hour						
	2032 DM (Flow 1)	2032 DM (Flow 2)	2032 DM (Two-Way)	2032 DS (full) (Flow 1)	2032 DS (full) (Flow 2)	2032 DS (full) Two-Way	2032 DS (full)-2032 DM Two-Way
Capesthorpe Road (Greenwood Crescent to Blackbrook Avenue)	577	407	984	812	570	1382	398
Capesthorpe Road (Poplars Ave - parallel to Humber Road)	484	322	806	711	477	1188	382
Cleveland Road	190	366	556	241	431	672	116
Cotswold Road	22	11	33	45	37	82	49
Howson Road	17	23	40	32	41	73	33
Greenwood Crescent (Darley Ave to Grasmere Ave)	5	3	8	8	6	14	6
Greenwood Crescent (Grasmere Ave to Meteor Cres)	44	49	93	44	49	93	0
Poplars Avenue - East of (Central) Site entrance	374	256	630	495	432	927	297
Poplars Avenue (Greenwood Cres - Capesthorpe Road)	505	786	1291	1014	616	1630	339
Poplars Avenue (south of Capesthorpe Road)	320	417	737	339	476	815	78
Sandy Lane West	552	513	1065	638	595	1233	168
Sandy Lane	186	419	605	189	443	632	27
Statham Avenue	362	95	457	434	102	536	79

6. **Table 4** provides the forecast daily flows (AADT24) for these 2032 Do Minimum and Do Something scenarios.

Table 4 – AADT24 Link flows within the study area (2032 Do Minimum and 2032 Do Something)

Link Name	AADT_24		
	2032 DM	2032 DS (Full)	2032 DS (Full) - 2032 DM
Capesthorpe Road (Greenwood Crescent to Blackbrook Avenue)	9004	12860	3856
Capesthorpe Road (Poplars Ave - parallel to Humber Road)	6771	10022	3251
Cleveland Road	5988	7234	1246
Cotswold Road	419	921	502
Howson Road	485	783	298
Greenwood Crescent (Darley Ave to Grasmere Ave)	1753	2277	524
Greenwood Crescent (Grasmere Ave to Meteor Cres)	3325	3611	287
Poplars Avenue - East of (Central) Site entrance	6809	9875	3066
Poplars Avenue (Greenwood Cres - Capesthorpe Road)	12984	16204	3220
Poplars Avenue (south of Capesthorpe Road)	8871	10365	1494
Sandy Lane West	10988	12670	1682
Sandy Lane	5955	6186	232
Statham Avenue	4819	5756	937

7. It can be seen from this flow information that the busier links account for use by through-traffic. A comparison between the 2022 and 2032 Do Minimum SATURN results demonstrate that the flows through the area are expected to substantially increase over time on the majority of links even without Peel Hall development traffic i.e. 200vph or around 2,000vpd.
8. It can also be seen that the increase in traffic as a result of the full Peel Hall development in 2032 varies across the links of between 1 to 461vph and 232 to 3,856vpd.

9. Furthermore, the Tables show development traffic impact to be very low on Sandy Lane and Howson Road (one vehicle every two to four minutes), with low increases of around 40 to 80vph on Cotswold Road, Greenwood Crescent and Statham Avenue i.e. around one vehicle per minute. Larger impacts are forecast on Cleveland Road and Sandy Lane West of around 110 to 170vph (two to three vehicles per minute) increasing to between 250 to 450vph Capesthorpe Road and Poplars Avenue i.e. four to seven vehicles per minute.

Traffic Capacity

10. The assessment procedure to determine the traffic capacity of urban roads is set out in Transport Advice Note TA 79/99 (May 1999) – see **Appendix 2**.
11. For the category UAP3 (Urban All Purpose Road Type 3 - variable standard roads carrying mixed traffic with HGV content less than 15%) it can be seen that this includes roads like those in the area to the immediate south of Peel Hall which have frontage access, side roads, bus stops and at-grade pedestrian crossings, and a 30mph speed restriction. Table 2 of this document gives the capacities of urban roads showing one-way hourly flows where the flows for a single carriageway are based upon a 60/40 directional split in the flow with the flows shown representing the busiest flow (60% figure).

Table 2 – TA 79/99

		Two-way Single Carriageway- Busiest direction flow (Assumes a 60/40 directional split)								Dual Carriageway				
		Total number of Lanes								Number of Lanes in each direction				
		2			2-3	3	3-4	4	4+	2		3	4	
Carriageway width		6.1m	6.75m	7.3m	9.0m	10.0m	12.3m	13.5m	14.6m	18.0m	6.75m	7.3m	11.0m	14.6m
Road type	UM	Not applicable										4000	5600	7200
	UAP1	1020	1320	1590	1860	2010	2550	2800	3050	3300	3350	3600	5200	*
	UAP2	1020	1260	1470	1550	1650	1700	1900	2100	2700	2950	3200	4800	*
	UAP3	900	1110	1300	1530	1620	*	*	*	*	2300	2600	3300	*
	UAP4	750	900	1140	1320	1410	*	*	*	*	*	*	*	*

**Table 2 Capacities of Urban Roads
One-way hourly flows in each direction**

Notes

1. Capacities are in vehicles per hour.
2. HGV ≤ 15%
3. (*) Capacities are excluded where the road width is not appropriate for the road type and where there are too few examples to give reliable figures.

12. The widths of the roads set out in **Tables 1 to 4** are set out in **Table 5**, together with the busiest direction peak hour flow limit identified in TA 79/99 Table 2 above.

Table 5 – Road Widths

Road	Width (metres)	TA 79/99 Table 2 – Busiest Direction Peak Hour Flow
Poplars Avenue	7.3	1300
Cotswold Road	7.3	1300
Cleveland Road	6.1	900
Howson Road	7.3	1300
Capesthorpe Rd (Poplars Ave. - parallel to Humber Dr)	6.1	900
Capesthorpe Rd (Greenwood Cres. - Blackbrook Ave.)	7.3	1300
Sandy Lane	7.3	1300
Sandy Lane West	6.1	900
Greenwood Crescent	7.3	1300
Statham Avenue	7.3	1300

13. Further guidance regarding traffic flow and safety for roads with frontage access is given in Manual for Streets (2007). Paragraph 7.9.5 contains the following:

7.9.5 It is recommended that the limit for providing direct access on roads with a 30 mph speed restriction is raised to at least 10,000 vehicles per day (see box).

Traffic flow and road safety for streets with direct frontage access

The relationship between traffic flow and road safety for streets with direct frontage access was researched for MFS. Data on recorded accidents and traffic flow for a total of 20 sites were obtained. All of the sites were similar in terms of land use (continuous houses with driveways), speed limit (30 mph) and geometry (single-carriageway roads with limited side-road junctions). Traffic flows at the sites varied from some 600 vehicles per day to some 23,000 vehicles per day, with an average traffic flow of some 4,000 vehicles per day.

It was found that very few accidents occurred involving vehicles turning into and out of driveways, even on heavily-trafficked roads.

Links with direct frontage access can be designed for significantly higher traffic flows than have been used in the past, and there is good evidence to raise this figure to 10,000 vehicles per day. It could be increased further, and it is suggested that local authorities review their standards with reference to their own traffic flows and personal injury accident records. The research indicated that a link carrying this volume of traffic, with characteristics similar to those studied, would experience around one driveway-related accident every five years per kilometre. Fewer accidents would be expected on links where the speed of traffic is limited to 20 mph or less, which should be the aim in residential areas.

14. From this it can be seen that:

- i. The Manual for Streets studies included roads with flows of 23,000vpd.
- ii. The guidance figure of 10,000vpd can be increased further.
- iii. Their studies showed that very few accidents occurred involving vehicles turning into and out of driveways.
- iv. Fewer accidents would be expected on links where the speed of traffic is limited to 20mph.

It should also be noted that the main changes in the approach to link capacity that Manual for Streets recommends (paragraph 1.6.1) are:

- Moving away from hierarchies of standard road types based on traffic flows and/or the number of buildings served.
- Designing to keep vehicle speeds at or below 20 mph on residential streets unless there are overriding reasons for accepting higher speeds.
- Using the minimum of highway design features necessary to make the streets work properly.

15. This information above (Manual for Streets, Table 2 of TA 79/99 and **Table 5**) is compared to the data in **Tables 2 to 4** to summarise the development impact on link flow capacity. This is set out in **Table 6**.

Table 6 – Summary for 2032 Development Impact on Link Capacity

Road	Comments
Poplars Avenue	<p>This road is around 7.3m wide and in the busiest peak hour (PM) the busiest directional flow forecast in 2032 (with development traffic) is 1,014vph between Greenwood Crescent and Capesthorne Road. This is well below the DMRB figure of 1,300vph in the busiest direction.</p> <p>The forecast AADT24 figures range from 6,809vpd to 12,984vpd for a 2032 'without development' scenario.</p> <p>The 'with development' forecast AADT24 figures range from 9,875vpd to 16,204vpd.</p>
Cotswold Road	<p>This road is around 7.3m wide and in the busiest peak hour (PM) with the busiest directional flow forecast in 2032 (with development traffic) of 46vph. This is well below the DMRB figure of 1,300vph in the busiest direction.</p> <p>The forecast AADT24 is 419vpd for a 2032 'without development' scenario.</p> <p>The 'with development' forecast AADT24 is 921vpd.</p>

Table 6 – continued...

Road	Comments
Cleveland Road	<p>This road is around 6.1m wide and in the busiest peak hour (PM) with the busiest directional flow forecast in 2032 (with development traffic) of 431vph. This is well below the DMRB figure of 900vph in the busiest direction.</p> <p>The forecast AADT24 is 5,988vpd for a 2032 'without development' scenario.</p> <p>The 'with development' forecast AADT24 is 7,234vpd.</p>
Howson Road	<p>This road is around 7.3m wide and in the busiest peak hour (AM) with the busiest directional flow forecast in 2032 (with development traffic) of 44vph. This is well below the DMRB figure of 1,300vph in the busiest direction.</p> <p>The forecast AADT24 is 485vpd for a 2032 'without development' scenario.</p> <p>The 'with development' forecast AADT24 is 783vpd.</p>
Capesthorpe Rd (Poplars Ave. - parallel to Humber Dr)	<p>This road is around 6.1m wide and in the busiest peak hour (PM) with the busiest directional flow forecast in 2032 (with development traffic) of 711vph. This is below the DMRB figure of 900vph in the busiest direction.</p> <p>The forecast AADT24 is 6,771vpd for a 2032 'without development' scenario.</p> <p>The 'with development' forecast AADT24 is 10,022vpd.</p>
Capesthorpe Rd (Greenwood Cres. - Blackbrook Ave.)	<p>This road is around 7.3m wide and in the busiest peak hour (PM) with the busiest directional flow forecast in 2032 (with development traffic) of 812vph. This is well below the DMRB figure of 1,300vph in the busiest direction.</p> <p>The forecast AADT24 is 9,004vpd for a 2032 'without development' scenario.</p> <p>The 'with development' forecast AADT24 is 12,860vpd.</p>
Sandy Lane	<p>This road is around 7.3m wide and in the busiest peak hour (PM) with the busiest directional flow forecast in 2032 (with development traffic) of 443vph. This is well below the DMRB figure of 1,300vph in the busiest direction.</p> <p>The forecast AADT24 is 5,955vpd for a 2032 'without development' scenario.</p> <p>The 'with development' forecast AADT24 is 6,186vpd.</p>

Table 6 – continued...

Road	Comments
Sandy Lane West	<p>This road is around 6.1m wide and in the busiest peak hour (PM) with the busiest directional flow forecast in 2032 (with development traffic) of 638vph. This is well below the DMRB figure of 900vph in the busiest direction.</p> <p>The forecast AADT24 is 10,988vpd for a 2032 'without development' scenario.</p> <p>The 'with development' forecast AADT24 is 12,670vpd.</p>
Greenwood Crescent	<p>This road is around 7.3m wide and in the busiest peak hour (AM) with the busiest directional flow forecast in 2032 (with development traffic) of 350vph. This is well below the DMRB figure of 1,300vph in the busiest direction.</p> <p>The highest forecast AADT24 is 3,325vpd for a 2032 'without development' scenario.</p> <p>The 'with development' highest forecast AADT24 is 3,611vpd.</p>
Statham Avenue	<p>This road is around 7.3m wide and in the busiest peak hour (PM) with the busiest directional flow forecast in 2032 (with development traffic) of 434vph. This is well below the DMRB figure of 1,300vph in the busiest direction.</p> <p>The forecast AADT24 is 4,819vpd for a 2032 'without development' scenario.</p> <p>The 'with development' forecast AADT24 is 5,756vpd.</p>

**Note – measurements based on a combination of topographical survey (where available) and OS mapping supplemented by Google Earth*

16. **Table 6** demonstrates that using the methodology set out in TA 79/99 none of the links exceed the threshold figure given in the advice note.
17. The roads within the immediate area to the south of the Peel Hall site are road type UAP3, such as Sandy Lane West, Poplars Avenue and Capesthorpe Road. These will remain as UAP3 roads with the addition of the Peel Hall traffic and it can therefore be seen that there will be no change in road hierarchy.
18. Furthermore, the recommendation within Manual for Streets is that the threshold figure is at least 10,000vpd (for a 30mph road) and it can be seen that the AADT24 figures are generally below this guideline on all roads except for Sandy Lane West, Poplars Avenue and Capesthorpe Road, which form the main established through-traffic route.
19. Therefore, from the Manual for Streets guidelines it is considered that the figures shown in **Table 6** are acceptable. Additionally, this 10,000vpd threshold would increase with a reduction in speed limit.

20. TA 79/99 further states in paragraph 3.6 that, "*..effective parking restrictions can lead to higher flows*" and it is considered that mitigation such as the provision of developer funding to extend the 20mph speed restriction along the entire length of Poplars Avenue and also into Capesthorne Road (between Poplars Avenue and Blackbrook Avenue), and to provide parking within the grass verges of these road links, which would be to formalise what occurs at present, will be beneficial (see HTP Technical Note TN/10 dated January 2020).

Summary

21. Whilst inevitably there will be an impact from development traffic on the amenity of the residents in the properties either side of the new accesses onto Poplars Avenue, both Poplars Avenue and the proposed access roads are designed to the appropriate standards i.e. Poplars Avenue is currently a 7.3 metre wide UAP3 road and will remain so apart from local widening to accommodate the access junction. The new access road will also be a road type UAP3.
22. The access junctions have been subject to Road Safety Audit and would be no different than the form of junction that you would see throughout an equivalent residential area.
23. Furthermore, in Transport for the Urban Environment it is set out on page 147 that, "*the existing pattern of land use has to be serviced by an affordable adaptation of the existing network, and much of which may have developed in haphazard ways over the history of the settlement. The initial definition of a hierarchy will necessarily have to be a practical compromise but identification of the current mixture of functions of each road and the scope for modifying it, over a period of time, is an important starting point for subsequent decisions about traffic management and development control, especially as it affects frontage access*".
24. As set out in Technical Note TN/10, a range of parking and traffic calming measures to the area to the south of the Peel Hall site are available to address the Inspector's concerns regarding safety in general and pedestrian safety in particular.
25. Therefore, in highway terms the impact of the development traffic on the area to the south, combined with the measures set out in HTP Technical Note TN/10 should be considered acceptable.

Appendix 1

AADT Methodology and Factors

Subject: RE: Peel Hall - AADT and AAWT
Date: Wednesday, 13 November 2019 at 08:21:04 Greenwich Mean Time
From: Taylor, Mike
To: Fiona Bennett
CC: dave.tighe, Wright, Colin, Dickin, Alan
Attachments: image001.png, image002.png

Fiona,

As per my previous email apologies for the delay.

The conversion factors have been identified as directional whereas it may be simpler to provide a flow-weighted average for each area; for example modification of Table 1 would give:

A49	AM	PM	24AADT	AADT Fac	18AAWT	AAWT Fac
NB	1096	1662	20435	14.819	20712	15.020
SB	1718	1362	20583	13.366	21035	13.659
TOTAL	2814	3024	41018	14.052	41747	14.302

I would appreciate your consideration and comment on this point.

Regards

Mike

Mike Taylor

Transport Development Control Team Leader

Environment and Transport Directorate
Transport for Warrington
Warrington Borough Council
New Town House, Buttermarket Street, Warrington, WA1 2NH

 mike.taylor@warrington.gov.uk

 Office: 01925 444086 Mobile: 07966 884639

warrington.gov.uk

From: Fiona Bennett [mailto:fiona.bennett@highgatetransportation.co.uk]
Sent: 25 October 2019 15:05
To: Taylor, Mike <mike.taylor@warrington.gov.uk>
Cc: dave.tighe <dave.tighe@highgatetransportation.co.uk>; Wright, Colin <Colin.Wright@wsp.com>; Dickin, Alan <adickin@warrington.gov.uk>
Subject: Peel Hall - AADT and AAWT

Afternoon Mike,

Please find attached the updated TN/08 (Revision A). Hopefully this will clarify matters.

Happy to discuss.

Subject: Re: Peel Hall - AADT and AAWT
Date: Wednesday, 13 November 2019 at 09:19:44 Greenwich Mean Time
From: Fiona Bennett
To: Taylor, Mike
CC: dave.tighe, Wright, Colin, Dickin, Alan
Attachments: image001.png, image002.png

Good morning Mike,

We are happy to provide a flow-weighted average for each area as you suggest in your email below. This will certainly make it simpler for all parties going forwards.

We will update the tables from TN/08/A following the methodology you set out in your modified Table 1 below, email across for your records and proceed on this basis for the provision of data to feed into the Noise and Air Quality assessments.

We should be in a position to send across the analysed WMMTM16 data in spreadsheet and flow diagram format shortly. Hopefully we can then arrange a meeting to discuss the next steps in terms of impact, analysis and mitigation.

Kind regards,
Fiona

Fiona Bennett
Highgate *Transportation*
Tel: 0117 934 9121
Mob: 07595 892 217
fiona.bennett@highgatetransportation.co.uk

www.highgatetransportation.co.uk

*Highgate Transportation Ltd
First Floor, 43-45 Park Street
BRISTOL BS1 5NL
Company Registration Number: 07500534*

This message (including any attachments) is confidential and intended for the addressee only. The material in it may also be subject to copyright protection. If you are not the addressee you are notified that any use, review, disclosure, or copying of the information in it is prohibited. If you have received this message in error please notify us and delete any copies of it. Whilst we take sensible precautions we cannot guarantee that this message or any attachments are virus free.

Please consider the environment before printing this email and any attachments.

From: "Taylor, Mike" <mike.taylor@warrington.gov.uk>
Date: Wednesday, 13 November 2019 at 08:21
To: Fiona Bennett <fiona.bennett@highgatetransportation.co.uk>
Cc: "dave.tighe" <dave.tighe@highgatetransportation.co.uk>, "Wright, Colin" <Colin.Wright@wsp.com>, "Dickin, Alan" <adickin@warrington.gov.uk>
Subject: RE: Peel Hall - AADT and AAWT

Fiona,

As per my previous email apologies for the delay.

The conversion factors have been identified as directional whereas it may be simpler to provide a flow-weighted average for each area; for example modification of Table 1 would give:

Subject: Peel Hall - Traffic Flow Data - AADT and AAWT Factors
Date: Thursday, 21 November 2019 at 14:28:24 Greenwich Mean Time
From: Fiona Bennett
To: Taylor, Mike
CC: dave.tighe, Wright, Colin, Dickin, Alan
Attachments: image001.png, image002.png, image003.png

Dear Mike,

I am about to send via WeTransfer Peel Hall flow diagrams across all scenarios for Access Strategy A, the accompanying spreadsheets and original AECOM datasets. We will send across the same for Access Strategy B shortly, once finalised.

In terms of AADT/AAWT factors, we have updated the tables from TN/08/A further to your email of 13th November as follows:

Table 1 – A49 flows and conversion factors

	AM Flow	PM Flow	24-hour Flow	24-hour AADT scale factor	18-hour Flow	18-hour AAWT scale factor
7-Day						
Northbound A49**			20,435	14.817		
Southbound A49**			20,583	13.366		
5-Day						
Northbound A49**	1,096	1,662			20,712	15.017
Southbound A49**	1,718	1,362			21,035	13.660
Total	2,814*	3,024*	41,018*	14.052	41,747*	14.302

** Figures taken directly from Excel 8551 – A49 Winwick Road – ATC Survey Results_FB

* Sum of tabulated figures

Table 2 – A50 flows and conversion factors

	AM Flow	PM Flow	24-hour Flow	24-hour AADT scale factor	18-hour Flow	18-hour AAWT scale factor
7-Day						
Westbound A50*			7,707	10.939		
Eastbound A50*			7,308	11.805		
5-Day						
Westbound A50*	712	697			8,170	11.595
Eastbound A50*	594	644			7,822	12.634
Total (as above)	1,306	1,341	15,015	11.345	15,992	12.083

* Figures taken directly from Excel Warrington A50 ATC_FB

Table 3 – Poplars Avenue flows and conversion factors

	AM Flow	PM Flow	24-hour Flow	24-hour AADT scale factor	18-hour Flow	18-hour AAWT scale factor
7-Day						
Westbound Poplars*			2,808	11.847		
Eastbound Poplars*			2,970	10.347		
5-Day						
Westbound Poplars*	171	303			2,843	11.995
Eastbound Poplars*	330	244			3,102	10.808
Total (as above)	501	547	5,778	11.027	5,945	11.345

Figures taken directly from Excel Warrington Poplars Avenue ATC_FB

Table 4 – Blackbrook Avenue flows and conversion factors

	AM Flow	PM Flow	24-hour Flow	24-hour AADT scale factor	18-hour Flow	18-hour AAWT scale factor
7-Day						
Northbound Blackbrook*			2,867	9.882		
Southbound Blackbrook*			3,294	8.298		
5-Day						
Northbound Blackbrook*	245	335			3,054	10.527
Southbound Blackbrook*	496	298			3,622	9.123
Total (as above)	741	633	6,161	8.968	6,676	9.718

Figures taken directly from Excel Warrington ATC 1115_FB

Table 5 – Delph Lane flows and conversion factors

	AM Flow	PM Flow	24-hour Flow	24-hour AADT scale factor	18-hour Flow	18-hour AAWT scale factor
7-Day						
Northbound Delph*			3,373	8.125		
Southbound Delph*			3,636	8.480		
5-Day						
Northbound Delph*	351	480			3,663	8.822
Southbound Delph*	500	358			3,931	9.168
Total (as above)	851	838	7,009	8.300	7,594	8.992

Figures taken directly from Excel Warrington Delph Lane ATC_FB

$$\text{AADT FACTOR} * ((\text{SATURN AM} + \text{PM peak hour two-way flows}) / 2) = \text{AADT}_{24}$$

$$\text{AAWT FACTOR} * ((\text{SATURN AM} + \text{PM peak hour two-way flows}) / 2) = \text{AAWT}_{18}$$

Table 6 – Summary of conversion factors

24-hour AADT	18-hour AAWT
A49	
14.052	14.302
A50	
11.345	12.083
Poplars Avenue	
11.027	11.345
Blackbrook Avenue	
8.968	9.718
Delph Lane	
8.300	8.992

Figure 2 TN/08/A - Areas for factors to be used

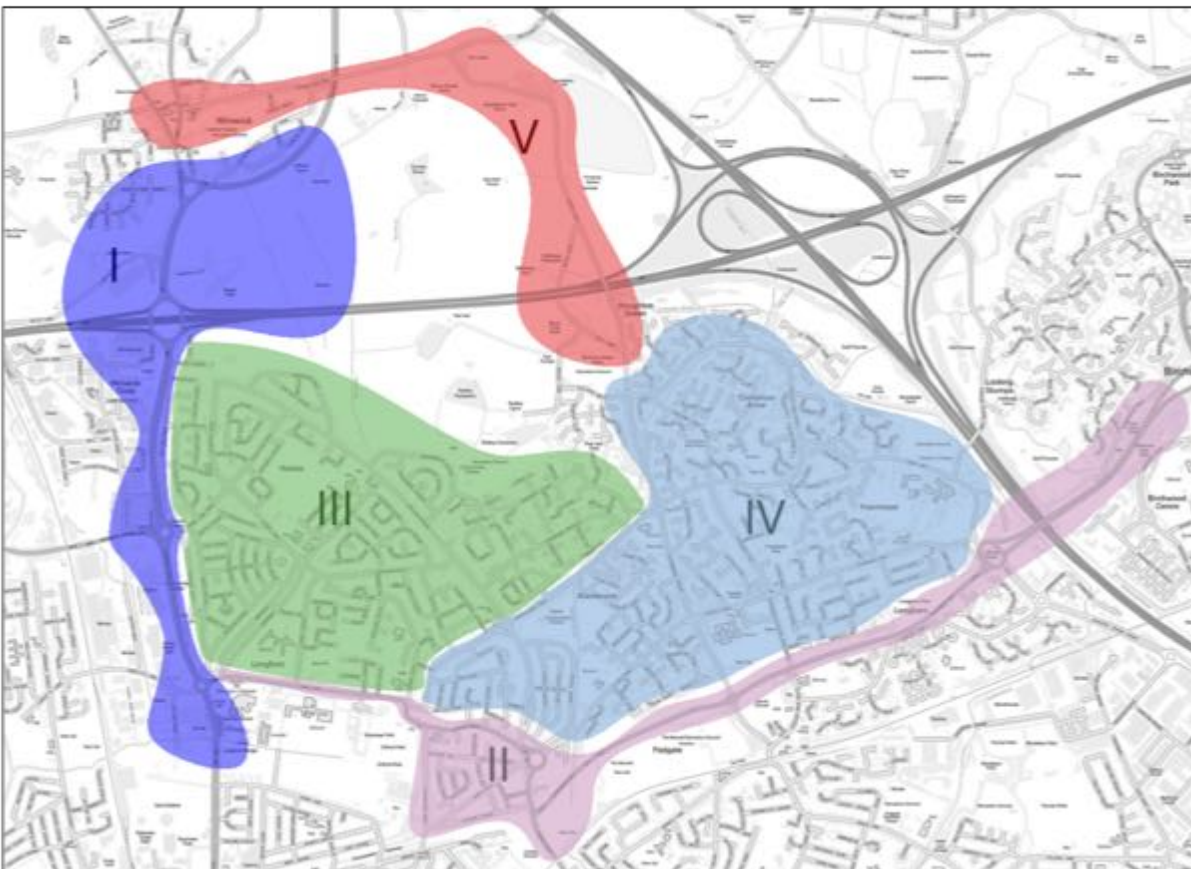

It would be good to have a meeting date in the diary for early December – please could you let us know your availability?

Kind regards,

Fiona

Fiona Bennett

Highgate *Transportation*

Tel: 0117 934 9121

Mob: 07595 892 217

fiona.bennett@highgatetransportation.co.uk

www.highgatetransportation.co.uk

Highgate Transportation Ltd

First Floor, 43-45 Park Street

BRISTOL BS1 5NL

Company Registration Number: 07500534

This message (including any attachments) is confidential and intended for the addressee only. The material in it may also be subject to copyright protection. If you are not the addressee you are notified that any use, review, disclosure, or copying of the information in it is prohibited. If you have received this message in error please notify us and delete any copies of it. Whilst we take sensible precautions we cannot guarantee that this message or any attachments are virus free.

Please consider the environment before printing this email and any attachments.

From: Fiona Bennett <fiona.bennett@highgatetransportation.co.uk>

Date: Wednesday, 13 November 2019 at 09:19

To: "Taylor, Mike" <mike.taylor@warrington.gov.uk>

Cc: "dave.tighe" <dave.tighe@highgatetransportation.co.uk>, "Wright, Colin" <Colin.Wright@wsp.com>, "Dickin, Alan" <adickin@warrington.gov.uk>

Subject: Re: Peel Hall - AADT and AAWT

Good morning Mike,

We are happy to provide a flow-weighted average for each area as you suggest in your email below. This will certainly make it simpler for all parties going forwards.

We will update the tables from TN/08/A following the methodology you set out in your modified Table 1 below, email across for your records and proceed on this basis for the provision of data to feed into the Noise and Air Quality assessments.

We should be in a position to send across the analysed WMMTM16 data in spreadsheet and flow diagram format shortly. Hopefully we can then arrange a meeting to discuss the next steps in terms of impact, analysis and mitigation.

Kind regards,

Fiona

Fiona Bennett

Highgate *Transportation*

Subject: Peel Hall - M62 AAWT and AADT Factors
Date: Monday, 25 November 2019 at 12:54:56 Greenwich Mean Time
From: Fiona Bennett
To: Laverick, Benjamin
CC: Gavin.Coupe@atkinsglobal.com, Dave Tighe (dave.tighe@highgatetransportation.co.uk)
Attachments: image001.png

Afternoon Ben,

Do you have appropriate AADT and 18-hour AAWT factors for the M62 mainline around Junction 9 that we can provide to the Air Quality and Noise teams for factoring up the AM+PM peak hour SATURN flows to corresponding Annual Average Daily Traffic and Annual Average Weekday Traffic?

We have the following factors for the A49:

24-hour AADT	18-hour AAWT
A49	
14.052	14.302

$$\text{AADT FACTOR} * ((\text{SATURN AM+PM peak hour two-way flows}) / 2) = \text{AADT24}$$

$$\text{AAWT FACTOR} * ((\text{SATURN AM+PM peak hour two-way flows}) / 2) = \text{AAWT18}$$

Happy to discuss.

Kind regards,
Fiona

Fiona Bennett
Highgate *Transportation*
Tel: 0117 934 9121
Mob: 07595 892 217
fiona.bennett@highgatetransportation.co.uk

www.highgatetransportation.co.uk

Highgate Transportation Ltd
First Floor, 43-45 Park Street
BRISTOL BS1 5NL
Company Registration Number: 07500534

This message (including any attachments) is confidential and intended for the addressee only. The material in it may also be subject to copyright protection. If you are not the addressee you are notified that any use, review, disclosure, or copying of the information in it is prohibited. If you have received this message in error please notify us and delete any copies of it. Whilst we take sensible precautions we cannot guarantee that this message or any attachments are virus free.

Please consider the environment before printing this email and any attachments.

Subject: Peel Hall - M62 AAWT and AADT Factors
Date: Tuesday, 26 November 2019 at 12:36:54 Greenwich Mean Time
From: Fiona Bennett
To: Laverick, Benjamin
CC: dave.tighe, Gavin.Coupe@atkinsglobal.com
Attachments: image001.png

Afternoon Ben,

Further to my email yesterday (below) where I asked if you were happy for us to use the factors provided for the A49 (using 2018 ATC data) to be applied to the M62 mainline future flows for obtaining AADT and AAWT from the AM and PM peak hour flows from the AECOM SATURN data, we have reviewed the AADT24 and AAWT18 2018 Do Minimum flow summaries from the mainline data provided by AECOM (WMMTM16 for Peel Hall) and this is summarised as:

Total two-way average daily traffic of 121,100 (PCU) *(as provided by AECOM)*

Total two-way AM flows of 9,634 (PCU) *(as provided in the dataset)*

Total two-way PM flows of 10,399 (PCU) *(as provided in the dataset)*

Approximate AADT24 M62 mainline Factor of 12.090

Total two-way average weekday traffic of 126,790 (PCU) *(as provided by AECOM)*

Total two-way AM flows of 9,634 (PCU) *(as provided in the dataset)*

Total two-way PM flows of 10,399 (PCU) *(as provided in the dataset)*

Approximate AAWT18 M62 mainline Factor of 12.658

We will move forward on the basis of the M62 mainline factors as set out above unless we hear otherwise today.

Happy to discuss.

Kind regards,
Fiona

Fiona Bennett

Highgate *Transportation*

Tel: 0117 934 9121

Mob: 07595 892 217

fiona.bennett@highgatetransportation.co.uk

www.highgatetransportation.co.uk

Highgate Transportation Ltd

First Floor, 43-45 Park Street

BRISTOL BS1 5NL

Company Registration Number: 07500534

This message (including any attachments) is confidential and intended for the addressee only. The material in it may also be subject to copyright protection. If you are not the addressee you are notified that any use, review, disclosure, or copying of the information in it is prohibited. If you have received this message in error please notify us and delete any copies of it. Whilst we take sensible precautions we cannot guarantee that this message or any attachments are virus free.

Please consider the environment before printing this email and any attachments.

From: Fiona Bennett <fiona.bennett@highgatetransportation.co.uk>

Date: Monday, 25 November 2019 at 12:54

To: "Laverick, Benjamin" <Benjamin.Laverick@highwaysengland.co.uk>

Cc: "Gavin.Coupe@atkinsglobal.com" <Gavin.Coupe@atkinsglobal.com>, "Dave Tighe"

Subject: RE: Peel Hall - M62 AAWT and AADT Factors
Date: Tuesday, 26 November 2019 at 14:03:10 Greenwich Mean Time
From: Laverick, Benjamin
To: Fiona Bennett
CC: dave.tighe
Attachments: image002.png

Hi Fiona,

I am content with the proposed factors as laid out below.

Kind regards

Ben

Benjamin Laverick, Assistant Asset Manager

Highways England | Piccadilly Gate | Store Street | Manchester | M1 2WD
Web: www.highwaysengland.co.uk

From: Fiona Bennett [mailto:fiona.bennett@highgatetransportation.co.uk]
Sent: 26 November 2019 12:37
To: Laverick, Benjamin <Benjamin.Laverick@highwaysengland.co.uk>
Cc: dave.tighe <dave.tighe@highgatetransportation.co.uk>; Gavin.Coupe@atkinglobal.com
Subject: Peel Hall - M62 AAWT and AADT Factors

Afternoon Ben,

Further to my email yesterday (below) where I asked if you were happy for us to use the factors provided for the A49 (using 2018 ATC data) to be applied to the M62 mainline future flows for obtaining AADT and AAWT from the AM and PM peak hour flows from the AECOM SATURN data, we have reviewed the AADT24 and AAWT18 2018 Do Minimum flow summaries from the mainline data provided by AECOM (WMMTM16 for Peel Hall) and this is summarised as:

Total two-way average daily traffic of 121,100 (PCU) *(as provided by AECOM)*
Total two-way AM flows of 9,634 (PCU) *(as provided in the dataset)*
Total two-way PM flows of 10,399 (PCU) *(as provided in the dataset)*
Approximate AADT24 M62 mainline Factor of 12.090

Total two-way average weekday traffic of 126,790 (PCU) *(as provided by AECOM)*
Total two-way AM flows of 9,634 (PCU) *(as provided in the dataset)*
Total two-way PM flows of 10,399 (PCU) *(as provided in the dataset)*
Approximate AAWT18 M62 mainline Factor of 12.658

We will move forward on the basis of the M62 mainline factors as set out above unless we hear otherwise today.

Happy to discuss.

Kind regards,
Fiona

Fiona Bennett
Highgate *Transportation*
Tel: 0117 934 9121
Mob: 07595 892 217

TECHNICAL NOTE

PROJECT: Peel Hall, Warrington

REPORT: 1901/TN/08/A – Conversion factors for 24-Hour AADT & 18-Hour AAWT

DATE: August 2019 (updated September 2019)

1. This Technical Note has been provided to set out the calculation factors for taking the Peel Hall WMMTM16 SATURN model AM and PM peak hour outputs and converting to 24-hour AADT¹ and 18-hour AAWT² (0600-2400 hours). This is for the purposes of the Air Quality and Noise Assessments required to support the development of land at Peel Hall, Warrington.
2. The factors are being determined from existing week-long ATC traffic count data from the following roads and the locations of these surveys are indicated on **Figure 1**.
 - i. A49 (2018)
 - ii. A50 (2019)
 - iii. Poplars Avenue (2019)
 - iv. Blackbrook Avenue (2015)
 - v. Delph Lane (2019)

Figure 1 – ATC Location Plan

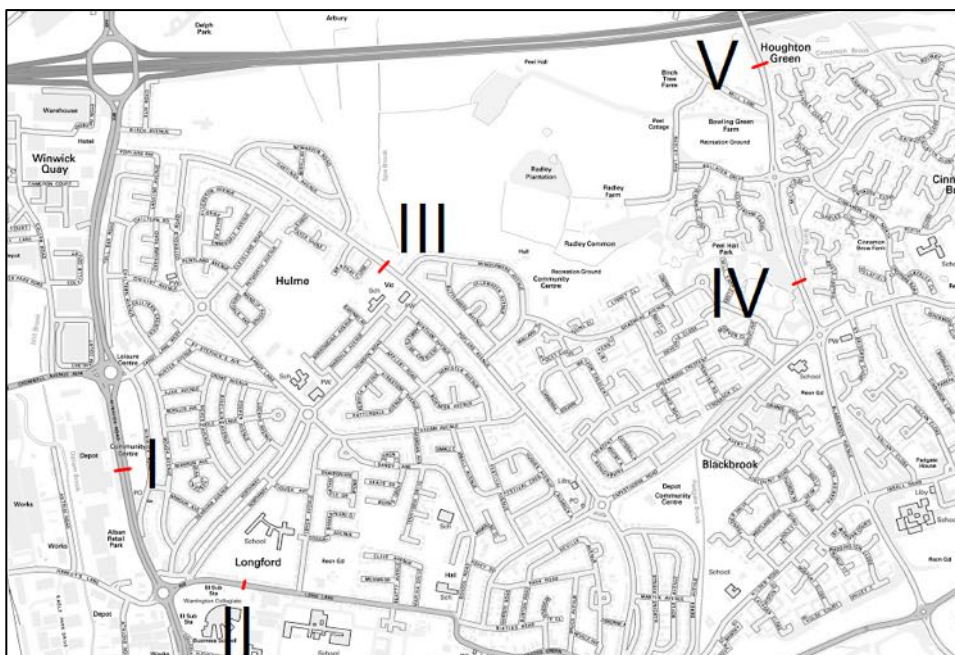

¹ Average Annual Daily Traffic (7-day)

² Average Annual Weekday traffic (5-day)

3. The AM (0800-0900) and PM (1700-1800) two-way weekday flows from the ATC data is provided with the 24-hour weekly data and 18-hour weekday for each site in turn below.
4. The resultant 24-hour AADT and 18-hour AAWT are then presented for agreement with Warrington Borough Council (WBC), using the 5-day average peak hour flows as these are what will be available from the SATURN outputs.

A49 – Traffic Data

5. Traffic surveys were undertaken along the A49 between the Sandy Lane West signalised roundabout and the Junction 9 Retail Park three-arm signal junction to the south. The survey was undertaken between Tuesday 20th March 2018 and Monday 2nd April 2018. Easter was Sunday 1st April in 2018, and the Warrington school holidays ran from Saturday 6th to Monday 22nd April that year. Therefore, the first week of this data has been used (20th to 26th March 2018).
6. The resultant summary data and conversion factors are provided in **Table 1**.

Table 1 – A49 flows and conversion factors

	AM Flow	PM Flow	24-hour Flow	18-hour Flow	24-hour AADT scale factor	18-hour AAWT scale factor
7-Day						
Northbound A49			20,435		14.817	
Southbound A49			20,583		13.366	
5-Day						
Northbound A49	1,096	1,662		20,712		15.017
Southbound A49	1,718	1,362		21,035		13.660

7. The ATC data is provided in **Appendix 1** for reference alongside the data analysis.
8. As set out at **Table 1**, the conversion factors to forecast 24-hour AADT using the peak hour flows from the SATURN model for the A49 corridor is 14.817 and 13.336 for northbound and southbound flows respectively.
9. The corresponding factors for forecasting 18-hour AAWT using the peak hour flows from the SATURN model for the A49 corridor is 15.017 and 13.660 for northbound and southbound flows respectively.
10. Therefore, these factors would be used as follows:

$$\text{AADT DIRECTIONAL FACTOR} * ((\text{AM} + \text{PM peak hour directional flows}) / 2) = \text{AADT24}$$

$$\text{AAWT DIRECTIONAL FACTOR} * ((\text{AM} + \text{PM peak hour directional flows}) / 2) = \text{AAWT18}$$

A50 – Traffic Data

11. Traffic surveys were undertaken along the A50. The survey was undertaken between Saturday 30th March 2019 and Friday 5th April 2019. Easter was Sunday 21st April in 2019, and the Warrington school holidays ran from either Saturday 6th or Saturday 13th to Tuesday 23rd or Monday 29th April that year.
12. The resultant summary data and conversion factors are provided in **Table 2**.

Table 2 – A50 flows and conversion factors

	AM Flow	PM Flow	24-hour Flow	18-hour Flow	24-hour AADT scale factor	18-hour AAWT scale factor
7-Day						
Westbound A50			7,707		10.939	
Eastbound A50			7,308		11.805	
5-Day						
Westbound A50	712	697		8,170		11.595
Eastbound A50	594	644		7,822		12.634

13. The ATC data is provided in **Appendix 2** for reference alongside the data analysis.
14. As set out at **Table 2**, the conversion factors to forecast 24-hour AADT using the peak hour flows from the SATURN model for the A50 corridor is 10.939 and 11.805 for westbound and eastbound flows respectively.
15. The corresponding factors for forecasting 18-hour AAWT using the peak hour flows from the SATURN model for the A50 corridor is 11.595 and 12.634 for westbound and eastbound flows respectively.
16. These factors would be applied as set out in **paragraph 10**.

Poplars Avenue – Traffic Data

17. Traffic surveys were undertaken at three locations along Poplars Avenue in March/April 2019. For the purposes of this assessment the busiest of the three locations has been used. This survey location was between the Poplars Avenue junctions with Newhaven Road and Windermere Avenue. The survey was undertaken between Saturday 30th March 2019 and Friday 5th April 2019.
18. The resultant summary data and conversion factors are provided in **Table 3**.

Table 3 – Poplars Avenue flows and conversion factors

	AM Flow	PM Flow	24-hour Flow	18-hour Flow	24-hour AADT scale factor	18-hour AAWT scale factor
7-Day						
Westbound Poplars			2,808		11.847	
Eastbound Poplars			2,970		10.347	
5-Day						
Westbound Poplars	171	303		2,843		11.995
Eastbound Poplars	330	244		3,102		10.808

19. The ATC data is provided in **Appendix 3** for reference alongside the data analysis.
20. As set out at **Table 3**, the conversion factors to forecast 24-hour AADT using the peak hour flows from the SATURN model for the Poplars Avenue area is 11.847 and 10.347 for westbound and eastbound flows respectively.
21. The corresponding factors for forecasting 18-hour AAWT using the peak hour flows from the SATURN model for the Poplars Avenue area is 11.995 and 10.808 for westbound and eastbound flows respectively.
22. These factors would be applied as set out in **paragraph 10**.

Blackbrook Avenue – Traffic Data

23. Traffic surveys were undertaken along Blackbrook Avenue adjacent to Peel Hall Park. The survey was undertaken between Friday 20th and Thursday 26th November 2015.
24. The resultant summary data and conversion factors are provided in **Table 4**.

Table 4 – Blackbrook Avenue flows and conversion factors

	AM Flow	PM Flow	24-hour Flow	18-hour Flow	24-hour AADT scale factor	18-hour AAWT scale factor
7-Day						
Northbound Blackbrook			2,867		9.882	
Southbound Blackbrook			3,294		8.298	
5-Day						
Northbound Blackbrook	245	335		3,054		10.527
Southbound Blackbrook	496	298		3,622		9.123

25. The ATC data is provided in **Appendix 4** for reference alongside the data analysis.

- 26. As set out at **Table 4**, the conversion factors to forecast 24-hour AADT using the peak hour flows from the SATURN model for the Blackbrook Avenue area is 9.882 and 8.298 for northbound and southbound flows respectively.
- 27. The corresponding factors for forecasting 18-hour AAWT using the peak hour flows from the SATURN model for the Blackbrook Avenue area is 10.527 and 9.123 for northbound and southbound flows respectively.
- 28. These factors would be applied as set out in **paragraph 10**.

Delph Lane – Traffic Data

- 29. Additional traffic surveys were undertaken along Delph Lane, effectively a continuation to the north of Blackbrook Avenue and the data reviewed against the older 2015 data. The survey was undertaken between Saturday 30th March 2019 and Friday 5th April 2019.
- 30. The resultant summary data and conversion factors are provided in **Table 5**.

Table 5 – Delph Lane flows and conversion factors

	AM Flow	PM Flow	24-hour Flow	18-hour Flow	24-hour AADT scale factor	18-hour AAWT scale factor
7-Day						
Northbound Delph			3,373		8.125	
Southbound Delph			3,636		8.480	
5-Day						
Northbound Delph	351	480		3,663		8.822
Southbound Delph	500	358		3,931		9.168

- 31. The ATC data is provided in **Appendix 5** for reference alongside the data analysis.
- 32. As set out at **Table 5**, the conversion factor to forecast 24-hour AADT using the peak hour flows from the SATURN model for the Delph Lane area is 8.125 and 8.480 for northbound and southbound flows respectively.
- 33. The corresponding factors for forecasting 18-hour AAWT using the peak hour flows from the SATURN model for the Delph Lane area is 8.822 and 9.126 for northbound and southbound flows respectively.
- 34. Given the 2019 data is more recent, it is considered that the factors from the Delph Lane data will be used to the areas north of the M62.
- 35. These factors would be applied as set out in **paragraph 10**.

Summary

- 36. This Technical Note has been provided to set out the calculation factors for taking the Peel Hall WMMTM16 SATURN model AM and PM peak hour outputs and converting to 24-hour AADT and 18-hour AAWT for the purposes of the Air Quality and Noise Assessments required to support the development of land at Peel Hall, Warrington.

37. The factors for 24-hour AADT and 18-hour AAWT flows are summarised at **Table 6**, with the corresponding links that these factors will be used for illustrated on **Figure 2**.

Table 6 – Summary of conversion factors

	24-hour AADT	18-hour AAWT
A49		
Northbound	14.817	15.017
Southbound	13.366	13.660
A50		
Westbound	10.939	11.595
Eastbound	11.805	12.634
Poplars Avenue		
Westbound	11.847	11.995
Eastbound	10.347	10.808
Blackbrook Avenue		
Northbound	9.882	10.527
Southbound	8.298	9.123
Delph Lane		
Northbound	8.125	8.822
Southbound	8.480	9.168

Figure 2 - Areas for factors to be used

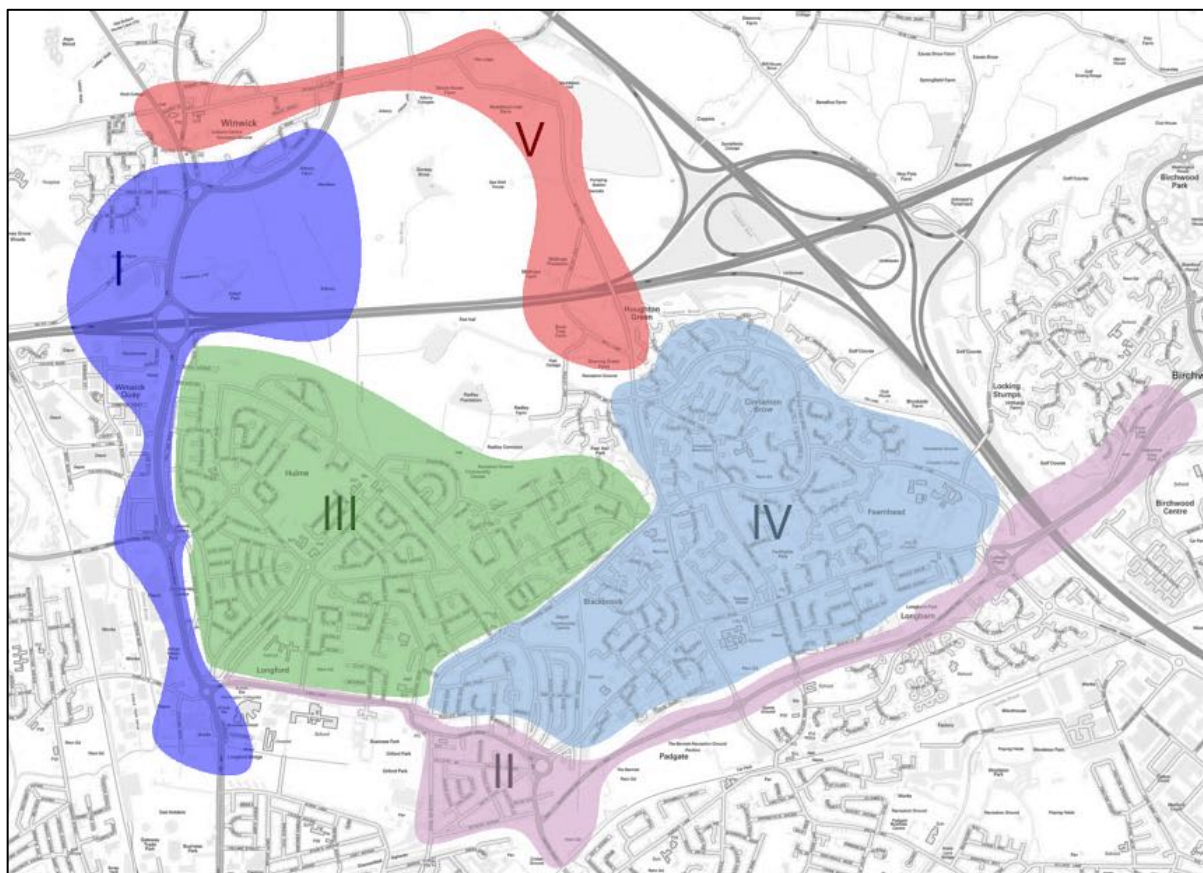

Appendix 1

ATC Data – A49

Tuesday 20 March 2018

Time	Total	Classification												JPSL	JPSL%	JSL1	JSL1%	JSL2	JSL2%	Mean	Vpp
		1	2	3	4	5	6	7	8	9	10	11	12								
	MCL	SV	SVT	TB2	TB3	T4	ART3	ART4	ART5	ART6	BD	DRT	40	ACPO	ACPO	DFT	DFT				
0000	0	69	0	9	1	1	0	8	12	4	0	0	23	5	4.8	0	0	36.9	41.2		
0100	0	43	0	14	2	0	0	2	13	1	0	0	19	3	4	0	0	36.8	42.3		
0200	0	29	0	14	0	0	0	1	6	7	0	1	11	4	6.9	0	0	35.7	40.9		
0300	0	50	0	16	0	0	0	2	3	2	0	0	26	8	11	0	0	38.5	43.6		
0400	2	60	0	24	0	0	0	0	7	5	0	0	32	5	5.1	1	1	37.3	43.6		
0500	1	291	2	50	1	2	0	7	4	9	1	0	98	18	4.9	2	0.5	37.5	42.3		
0600	8	454	9	75	9	5	1	16	7	11	0	1	157	30	5	2	0.3	37.2	42.3		
0700	8	881	16	112	18	6	5	32	8	12	0	5	118	14	1.3	1	0.1	32.2	38.7		
0800	5	861	22	110	13	10	2	26	9	10	3	3	43	8	0.7	0	0	30.3	35.3		
0900	6	868	17	111	15	10	4	26	16	11	3	7	44	3	0.3	1	0.1	30.2	35.1		
1000	4	931	15	137	7	16	3	23	10	7	1	3	35	3	0.3	0	0	29.1	34.9		
1100	6	1077	20	116	18	4	2	21	11	15	1	3	30	5	0.4	0	0	28.4	34		
1200	8	1135	18	114	17	11	6	23	10	12	3	5	28	3	0.2	0	0	27.1	32.7		
1300	10	1265	22	88	8	14	3	28	10	7	3	7	32	2	0.1	0	0	28.9	34		
1400	12	1358	27	121	14	14	2	28	9	10	1	5	26	1	0.1	0	0	26.1	32.9		
1500	11	1420	38	98	7	7	4	40	12	12	5	3	13	1	0.1	0	0	26.1	33.1		
1600	19	1612	45	71	25	17	3	36	5	16	5	6	4	0	0	0	0	20.6	28.4		
1700	8	1572	54	44	16	10	1	62	2	13	4	9	15	1	0.1	1	0.1	22.9	30.9		
1800	4	1295	32	45	7	3	2	37	5	14	1	3	39	5	0.3	0	0	29.7	34.9		
1900	4	975	20	39	4	3	2	25	10	6	1	3	36	5	0.5	0	0	30.1	34.7		
2000	2	790	12	31	3	3	0	21	13	7	0	4	54	14	1.6	3	0.3	32.2	37.4		
2100	1	543	8	27	3	2	0	7	12	4	0	0	51	14	2.3	1	0.2	33.1	37.4		
2200	4	298	4	15	0	0	1	3	12	6	0	0	66	12	3.5	1	0.3	35	41.2		
2300	3	154	0	15	1	0	0	4	20	1	0	0	49	14	7.1	1	0.5	37.3	41.6		
07-19	101	14275	326	1167	165	122	37	382	107	139	30	59	427	46	0.3	3	0	27.1	34		
06-22	116	17037	375	1339	184	135	40	451	149	167	31	67	725	109	0.5	9	0	28	34.9		
06-00	123	17489	379	1369	185	135	41	458	181	174	31	67	840	135	0.7	11	0.1	28.2	35.1		
00-00	126	18031	381	1496	189	138	41	478	226	202	32	68	1049	178	0.8	14	0.1	28.5	35.6		



1
A49 Winwick Road -N53.412624, W2.597562
Northbound
Wednesday 21 March 2018

Site
Location
Direction

Time	Total	Classification												JPSL 40	JPSL% 40	JSL1 46 ACPO	JSL1% 46 ACPO	JSL2 55 DFT	JSL2% 55 DFT	Mean	Vpp 85
		1 MCL	2 SV	3 SVT	4 TB2	5 TB3	6 T4	7 ART3	8 ART4	9 ART5	10 ART6	11 BD	12 DRT								
0000	123	0	90	1	9	0	0	1	9	11	2	0	0	28	22.8	4	3.3	1	0.8	36.6	40.9
0100	70	0	39	1	14	1	0	0	1	10	4	0	0	17	24.3	5	7.1	0	0	36.9	41.2
0200	69	1	43	0	10	1	0	0	2	7	5	0	0	17	24.6	5	7.2	0	0	37.6	41.6
0300	63	0	41	0	13	1	0	0	0	6	2	0	0	18	28.6	5	7.9	1	1.6	38.4	43.8
0400	96	1	56	0	24	0	0	0	4	5	6	0	0	27	28.1	13	13.5	0	0	38.2	45.2
0500	356	3	296	4	33	2	3	0	6	4	5	0	0	119	33.4	27	7.6	3	0.8	38.4	43.2
0600	575	5	441	7	75	6	11	1	10	6	11	0	2	157	27.3	40	7	5	0.9	37.8	42.5
0700	1149	6	913	17	125	13	11	2	32	10	11	2	7	108	9.4	17	1.5	4	0.3	32.3	38.5
0800	1085	6	846	22	130	12	14	3	28	11	10	0	3	56	5.2	6	0.6	0	0	30.6	36.2
0900	1107	3	881	26	119	7	8	4	28	10	16	2	3	39	3.5	2	0.2	0	0	29.1	35.1
1000	1153	3	936	24	120	13	8	4	23	7	12	3	0	47	4.1	9	0.8	2	0.2	30.2	35.1
1100	1287	6	1100	14	93	5	5	2	41	6	8	1	6	28	2.2	6	0.5	1	0.1	29.2	34.4
1200	1324	6	1112	12	121	8	10	2	27	11	10	1	4	40	3	6	0.5	1	0.1	27.5	34.2
1300	1466	6	1225	36	105	13	16	1	37	7	16	3	1	36	2.5	2	0.1	0	0	29	34
1400	1701	7	1462	19	131	21	11	10	22	5	6	5	2	11	0.6	2	0.1	1	0.1	22.1	30.9
1500	1662	5	1427	41	100	21	5	3	36	4	11	3	6	16	1	2	0.1	0	0	25.5	32.2
1600	1760	12	1507	50	72	23	14	4	46	6	18	3	5	9	0.5	4	0.2	0	0	23.1	30.4
1700	1460	9	1259	55	28	21	14	6	44	3	10	5	6	3	0.2	0	0	0	0	12.4	16.6
1800	1496	4	1325	39	28	16	9	4	49	4	12	3	3	6	0.4	0	0	0	0	18.1	28
1900	1091	5	980	18	40	4	2	1	23	10	5	1	2	23	2.1	6	0.5	1	0.1	29.4	33.6
2000	892	4	801	17	20	2	0	0	25	9	10	1	3	49	5.5	10	1.1	1	0.1	31.2	36.5
2100	646	5	576	8	24	2	3	0	12	14	1	0	1	71	11	17	2.6	1	0.2	33.7	38.7
2200	409	3	382	2	13	1	0	0	2	4	2	0	0	75	18.3	20	4.9	5	1.2	35.7	40.3
2300	217	1	167	0	19	3	0	0	3	20	3	0	1	49	22.6	13	6	5	2.3	37.1	40.9
07-19	16650	73	13993	355	1172	173	125	45	413	84	140	31	46	399	2.4	56	0.3	9	0.1	25.2	33.6
06-22	19854	92	16791	405	1331	187	141	47	483	123	167	33	54	699	3.5	129	0.6	17	0.1	26.3	34.7
06-00	20480	96	17340	407	1363	191	141	47	488	147	172	33	55	823	4	162	0.8	27	0.1	26.6	34.9
00-00	21257	101	17905	413	1466	196	144	48	510	190	196	33	55	1049	4.9	221	1	32	0.2	27.1	35.6



Time	Total	Classification												JPSL	JPSL%	JSL1 ACPO	JSL1%	JSL2 DFT	JSL2%	Mean	Vpp
		1 MCL	2 SV	3 SVT	4 TB2	5 TB3	6 T4	7 ART3	8 ART4	9 ART5	10 ART6	11 BD	12 DRT								
0000	105	1	75	0	8	0	0	0	6	11	4	0	0	28	26.7	7	6.7	1	1	37.1	42.7
0100	69	0	40	0	13	0	0	0	2	10	4	0	0	14	20.3	5	7.2	2	2.9	36.5	40.9
0200	70	1	46	0	14	0	0	0	2	6	1	0	0	26	37.1	7	10	2	2.9	39	44.7
0300	67	0	40	1	12	0	0	0	2	8	4	0	0	21	31.3	6	9	1	1.5	38.3	43.8
0400	102	2	67	1	26	0	0	0	0	5	1	0	0	29	28.4	11	10.8	1	1	37.3	43.2
0500	383	3	313	2	44	3	2	0	4	6	6	0	0	112	29.2	26	6.8	2	0.5	37.7	42.3
0600	629	8	472	11	85	7	7	1	15	11	11	1	0	179	28.5	36	5.7	5	0.8	37.6	42.7
0700	1084	6	868	12	116	9	12	5	30	10	11	1	4	116	10.7	13	1.2	1	0.1	33.2	38.9
0800	1127	4	894	20	116	9	10	4	32	15	17	5	1	54	4.8	9	0.8	0	0	31	36.7
0900	1122	4	880	15	144	10	8	3	26	15	9	4	4	57	5.1	9	0.8	1	0.1	30.2	35.6
1000	1178	5	949	17	120	15	16	1	31	11	9	2	2	33	2.8	5	0.4	0	0	30.2	34.7
1100	1338	2	1098	23	119	15	11	4	34	13	16	0	3	30	2.2	2	0.1	0	0	29.8	34.7
1200	1413	2	1185	19	103	13	15	3	32	11	18	5	7	37	2.6	6	0.4	1	0.1	29.6	34
1300	1497	5	1248	33	122	11	11	7	32	8	14	0	6	33	2.2	3	0.2	0	0	28.6	34
1400	1498	10	1284	31	83	25	10	8	25	7	10	1	4	5	0.3	1	0.1	0	0	19.1	28.9
1500	1656	12	1411	38	99	17	15	1	33	13	13	2	2	43	2.6	6	0.4	2	0.1	25.9	32.7
1600	1794	8	1555	45	62	22	11	7	51	10	9	4	10	15	0.8	1	0.1	0	0	22.1	30.2
1700	1843	9	1625	47	52	12	11	4	60	5	10	3	5	13	0.7	5	0.3	1	0.1	22.5	30.2
1800	1479	8	1318	40	49	9	3	2	35	3	10	0	2	61	4.1	11	0.7	1	0.1	29.8	35.6
1900	1105	3	987	22	30	12	2	2	24	12	9	1	1	35	3.2	4	0.4	0	0	29.9	34.4
2000	973	2	875	24	27	4	3	1	14	14	6	1	2	78	8	23	2.4	2	0.2	32.7	37.6
2100	603	3	541	9	21	3	1	0	7	12	3	2	1	96	15.9	17	2.8	2	0.3	34.3	40
2200	385	6	349	2	11	0	1	1	5	6	4	0	0	80	20.8	17	4.4	2	0.5	35.9	40.9
2300	201	0	160	0	12	0	0	0	4	20	5	0	0	61	30.3	21	10.4	3	1.5	38.1	43.8
07-19	17029	75	14315	340	1185	167	133	49	421	121	146	27	50	497	2.9	71	0.4	7	0	27.1	34.2
06-22	20339	91	17190	406	1348	193	146	53	481	170	175	32	54	885	4.4	151	0.7	16	0.1	28.1	35.1
06-00	20925	97	17699	408	1371	193	147	54	490	196	184	32	54	1026	4.9	189	0.9	21	0.1	28.3	35.6
00-00	21721	104	18280	412	1488	196	149	54	506	242	204	32	54	1256	5.8	251	1.2	30	0.1	28.6	36

Time	Total	Classification												JPSL 40	JPSL% 40	JSL1 46 ACPO	JSL1% 46 ACPO	JSL2 55 DFT	JSL2% 55 DFT	Mean	Vpp 85	
		1 MCL	2 SV	3 SVT	4 TB2	5 TB3	6 T4	7 ART3	8 ART4	9 ART5	10 ART6	11 BD	12 DRT									
0000	122	1	82	0	16	2	1	0	5	11	4	0	0	0	29	23.8	5	4.1	2	1.6	37.3	41.8
0100	86	0	51	0	16	0	0	0	4	10	5	0	0	0	23	26.7	4	4.7	0	0	36.5	41.6
0200	74	0	53	0	10	0	1	0	2	4	4	0	0	0	28	37.8	8	10.8	0	0	39.1	44.7
0300	61	0	44	0	8	0	0	0	2	5	2	0	0	0	20	32.8	7	11.5	1	1.6	38.7	44.3
0400	107	2	70	0	21	0	0	0	2	10	2	0	0	0	38	35.5	8	7.5	0	0	38.2	42.9
0500	358	1	289	3	41	4	1	1	3	7	7	0	1	1	113	31.6	22	6.1	2	0.6	37.9	42.5
0600	625	7	487	5	86	8	10	0	11	4	7	0	0	0	190	30.4	48	7.7	7	1.1	37.6	42.9
0700	1115	8	851	24	130	12	20	4	30	8	19	3	6	6	113	10.1	11	1	4	0.4	32.2	38.3
0800	1099	4	859	25	128	15	9	2	30	11	11	1	4	4	67	6.1	13	1.2	0	0	31.1	37.1
0900	1147	3	915	24	123	7	14	0	31	13	13	3	1	1	28	2.4	4	0.3	0	0	29.1	34.4
1000	1255	5	1020	26	122	14	11	3	22	10	14	1	7	7	38	3	4	0.3	0	0	29.9	35.1
1100	1409	10	1217	21	103	10	9	6	22	4	4	1	2	2	8	0.6	2	0.1	0	0	23.5	31.8
1200	1538	9	1299	23	114	16	14	2	35	3	20	2	1	1	24	1.6	2	0.1	0	0	26.8	33.6
1300	1569	4	1349	21	111	13	12	2	22	10	14	2	9	9	17	1.1	1	0.1	0	0	26.1	32.9
1400	1572	9	1348	29	67	25	19	7	39	1	16	1	11	11	4	0.3	0	0	0	0	17.8	26.4
1500	1686	6	1445	33	90	18	17	4	43	12	14	3	1	1	14	0.8	1	0.1	0	0	24	31.3
1600	1868	10	1647	44	74	9	13	1	46	3	15	3	3	3	7	0.4	0	0	0	0	22.1	29.3
1700	1784	13	1591	44	42	13	12	3	36	5	17	2	6	6	28	1.6	2	0.1	1	0.1	25.2	32.7
1800	1388	9	1240	30	40	5	5	0	41	9	6	2	1	1	59	4.3	8	0.6	4	0.3	31.3	36
1900	1002	2	890	25	39	4	3	0	22	8	5	2	2	2	33	3.3	10	1	2	0.2	30.7	35.1
2000	727	3	644	16	21	2	3	0	18	12	6	0	2	2	61	8.4	10	1.4	2	0.3	32.7	37.6
2100	823	6	740	16	15	7	2	1	15	16	0	1	4	4	63	7.7	13	1.6	2	0.2	29	37.1
2200	604	5	534	4	26	7	10	1	8	4	5	0	0	0	59	9.8	10	1.7	0	0	27.8	37.8
2300	271	1	233	1	11	0	0	0	6	16	3	0	0	0	48	17.7	12	4.4	0	0	35.7	41.4
07-19	17430	90	14781	344	1144	157	155	34	397	89	163	24	52	52	407	2.3	48	0.3	9	0.1	26.1	33.8
06-22	20607	108	17542	406	1305	178	173	35	463	129	181	27	60	60	754	3.7	129	0.6	22	0.1	27	34.7
06-00	21482	114	18309	411	1342	185	183	36	477	149	189	27	60	60	861	4	151	0.7	22	0.1	27.1	34.9
00-00	22290	118	18898	414	1454	191	186	37	495	196	213	27	61	61	1112	5	205	0.9	27	0.1	27.5	35.6

Time	Total	Classification												JPSL	JPSL%	JSL1	JSL1%	JSL2	JSL2%	Mean	Vpp
		1	2	3	4	5	6	7	8	9	10	11	12								
	MCL	SV	SVT	TB2	TB3	T4	ART3	ART4	ART5	ART6	BD	DRT	40	ACPO	ACPO	DFT					
0000	0	166	0	13	0	0	1	4	11	4	0	0	42	16	8	1	21.1	8	37.4	41.6	
0100	1	94	0	12	2	0	0	2	8	3	0	0	25	12	9.8	2	20.5	9.8	37.7	40.5	
0200	0	63	0	11	0	0	0	5	8	5	0	0	24	8	8.7	1	26.1	8.7	38	43.8	
0300	0	73	0	12	0	0	0	0	3	2	0	0	29	9	10	3	32.2	10	39.5	44.3	
0400	1	70	1	16	0	0	0	2	6	7	0	0	38	5	4.9	2	36.9	4.9	37.7	42.1	
0500	4	189	3	21	0	0	0	0	5	7	0	0	69	17	7.4	3	30.1	7.4	38	42.9	
0600	2	236	3	38	2	1	0	3	2	3	0	0	104	24	8.3	0	35.9	8.3	38.3	43.4	
0700	1	415	4	60	3	7	1	6	2	5	0	1	112	19	3.8	3	22.2	3.8	36.2	41.4	
0800	1	599	13	59	7	10	1	13	2	5	0	0	82	17	2.4	3	11.5	2.4	33.9	39.1	
0900	3	843	17	76	5	11	2	26	3	2	1	1	67	7	0.7	4	6.8	0.7	31.4	36.7	
1000	7	1122	19	50	6	6	2	28	3	4	0	2	42	8	0.6	2	3.4	0.6	30.5	35.6	
1100	3	1360	31	40	6	11	2	33	3	1	1	3	25	5	0.3	1	1.7	0.3	28.9	33.8	
1200	5	1456	47	35	20	10	5	35	1	10	1	2	4	1	0.1	0	0.2	0.1	21.9	28.6	
1300	11	1554	42	34	9	6	0	39	1	7	1	1	8	1	0.1	0	0.5	0.1	22.5	29.8	
1400	11	1512	35	42	13	8	3	31	0	6	2	1	8	0	0	0	0.5	0	23.5	30	
1500	9	1532	29	37	11	10	5	24	2	7	1	6	9	2	0.1	1	0.5	0.1	24.7	30.6	
1600	4	1496	39	44	12	7	2	34	1	2	2	5	25	5	0.3	2	1.5	0.3	27.7	33.1	
1700	3	1427	37	37	5	6	1	33	0	8	1	2	34	5	0.3	0	2.2	0.3	29.1	33.8	
1800	5	1093	28	22	6	5	1	28	1	2	0	0	36	6	0.5	0	3	0.5	31	35.8	
1900	3	743	10	12	8	1	1	16	3	1	1	2	72	12	1.5	3	9	1.5	32.3	37.6	
2000	2	531	10	9	0	0	1	7	1	4	0	0	61	15	2.7	1	10.8	2.7	33	38.3	
2100	7	412	5	14	1	0	1	3	0	3	0	0	64	25	5.6	2	14.3	5.6	34.6	39.6	
2200	1	303	2	6	1	1	0	0	0	0	0	0	77	20	6.4	3	24.5	6.4	37.2	41.6	
2300	0	250	1	6	1	0	0	1	1	0	0	0	64	11	4.2	4	24.6	4.2	37.3	41.4	
07-19	63	14409	341	536	103	97	25	330	19	59	10	24	452	76	0.5	16	2.8	0.5	27.3	34	
06-22	77	16331	369	609	114	99	28	359	25	70	11	26	753	152	0.8	22	4.2	0.8	28.1	34.9	
06-00	78	16884	372	621	116	100	28	360	26	70	11	26	894	183	1	29	4.8	1	28.3	35.3	
00-00	84	17539	376	706	118	100	29	373	67	98	11	26	1121	250	1.3	41	5.7	1.3	28.7	36	



Time	Total	Classification												JPSL 40	JPSL% 40	JSL1 46 ACPO	JSL1% 46 ACPO	JSL2 55 DFT	JSL2% 55 DFT	Mean	Vpp 85	
		1 MCL	2 SV	3 SVT	4 TB2	5 TB3	6 T4	7 ART3	8 ART4	9 ART5	10 ART6	11 BD	12 DRT									
0000	220	2	196	0	17	1	2	0	1	1	0	0	0	0	66	30	9	4.1	2	0.9	37.2	42.7
0100	125	0	107	1	13	0	0	1	0	2	1	0	0	0	46	36.8	10	8	0	0	38.8	43.6
0200	117	2	105	0	6	0	0	0	1	3	0	0	0	0	41	35	17	14.5	2	1.7	39.1	45.2
0300	115	0	108	0	3	0	0	0	2	0	2	0	0	0	33	28.7	7	6.1	0	0	37.9	41.8
0400	158	0	148	2	7	0	0	0	1	0	0	0	0	0	42	26.6	16	10.1	3	1.9	38	42.9
0500	172	2	151	1	13	0	0	0	1	2	2	0	0	0	58	33.7	16	9.3	2	1.2	38.8	43.4
0600	351	1	321	3	22	2	0	0	1	1	0	0	0	0	114	32.5	26	7.4	3	0.9	38.3	43.4
0700	450	2	399	0	41	1	1	0	2	3	0	1	0	0	129	28.7	23	5.1	5	1.1	37.8	42.9
0800	623	6	571	6	24	3	2	3	7	0	1	0	0	0	119	19.1	24	3.9	5	0.8	36.3	40.9
0900	888	11	786	18	41	7	3	0	15	4	1	1	1	1	105	11.8	19	2.1	3	0.3	33.3	38.7
1000	1215	13	1092	28	38	7	7	1	22	0	5	1	1	1	30	2.5	6	0.5	1	0.1	30.3	34.7
1100	1452	10	1321	35	40	4	3	0	28	0	8	1	2	2	12	0.8	0	0	0	0	28.1	32.7
1200	1525	4	1388	40	33	5	4	2	37	0	10	0	2	2	11	0.7	1	0.1	0	0	27.2	32
1300	1527	16	1382	43	25	7	7	2	33	2	8	1	1	1	14	0.9	2	0.1	0	0	28.3	32.9
1400	1485	6	1365	34	29	7	5	2	31	0	2	1	3	3	41	2.8	4	0.3	0	0	30.1	34.4
1500	1312	8	1222	16	23	4	6	2	22	1	6	0	2	2	61	4.6	8	0.6	4	0.3	30.9	36
1600	1035	6	956	17	32	3	3	0	14	0	4	0	0	0	115	11.1	33	3.2	5	0.5	33.3	38.7
1700	708	9	645	8	13	1	4	0	20	3	3	0	2	2	136	19.2	33	4.7	8	1.1	35.9	40.5
1800	687	4	636	10	15	3	2	0	11	0	4	0	2	2	72	10.5	15	2.2	2	0.3	33.5	38.7
1900	587	1	545	15	12	3	1	0	8	1	1	0	0	0	68	11.6	16	2.7	2	0.3	34	39.1
2000	396	5	359	11	9	0	1	0	9	0	2	0	0	0	61	15.4	14	3.5	5	1.3	34.7	40
2100	242	2	223	1	10	0	1	0	1	2	2	0	0	0	71	29.3	22	9.1	2	0.8	37.4	43.6
2200	157	3	142	0	5	1	0	0	3	1	2	0	0	0	34	21.7	8	5.1	1	0.6	36.9	41.2
2300	106	1	92	0	8	0	0	0	3	1	1	0	0	0	41	38.7	11	10.4	5	4.7	38.9	44.5
07-19	12907	95	11763	255	354	52	47	12	242	13	52	6	16	16	845	6.5	168	1.3	33	0.3	31	36.7
06-22	14483	104	13211	285	407	57	50	12	261	17	57	6	16	16	1159	8	246	1.7	45	0.3	31.5	37.4
06-00	14746	108	13445	285	420	58	50	12	267	19	60	6	16	16	1234	8.4	265	1.8	51	0.3	31.6	37.6
00-00	15653	114	14260	289	479	59	52	13	273	27	65	6	16	16	1520	9.7	340	2.2	60	0.4	32	38.3

Monday 26 March 2018

Time	Total	Classification												JPSL	JPSL%	JSL1	JSL1%	JSL2	JSL2%	Mean	Vpp
		1	2	3	4	5	6	7	8	9	10	11	12								
	MCL	SV	SVT	TB2	TB3	T4	ART3	ART4	ART5	ART6	BD	DRT	40	ACPO	ACPO	DFT	DFT				
0000	0	35	0	3	1	0	0	0	0	1	0	0	12	2	5	0	0	37.1	42.3		
0100	0	25	0	12	0	0	0	2	2	1	0	0	20	5	11.9	2	4.8	40	44.5		
0200	0	35	0	14	0	0	0	0	3	2	0	0	15	3	5.6	1	1.9	37.7	42.9		
0300	0	68	0	11	0	0	0	2	1	3	0	0	19	3	3.5	0	0	36.2	40.7		
0400	3	282	4	37	1	1	1	3	2	5	0	0	88	17	5	1	0.3	37.9	42.5		
0500	2	465	9	79	3	11	0	15	2	4	0	1	150	27	4.6	4	0.7	36.7	42.1		
0600	8	853	19	99	11	8	2	25	10	9	1	2	116	27	2.6	1	0.1	32.3	38.7		
0700	5	902	26	101	8	9	5	24	6	8	2	5	80	15	1.4	2	0.2	31.7	37.1		
0800	4	851	27	128	12	13	3	24	13	17	0	4	49	10	0.9	0	0	31.3	36		
0900	2	936	23	137	10	10	4	22	17	13	1	4	47	10	0.8	0	0	31	36		
1000	7	1079	19	123	12	10	1	34	11	15	2	5	38	10	0.8	0	0	28.9	34.4		
1100	4	1292	20	132	9	10	2	36	9	13	2	3	23	4	0.3	1	0.1	28	33.8		
1200	10	1246	35	108	9	14	3	37	9	17	0	3	29	5	0.3	0	0	29	34		
1300	9	1406	27	103	14	12	6	45	10	6	0	2	21	1	0.1	0	0	27	32.4		
1400	8	1326	28	96	17	11	8	25	7	11	2	8	13	3	0.2	0	0	23	32		
1500	10	1581	44	67	24	12	5	39	3	13	0	4	9	3	0.2	0	0	19.3	27.3		
1600	8	1617	44	38	25	16	6	43	0	5	3	5	1	1	0.1	0	0	16.8	22.8		
1700	7	1264	41	40	6	9	2	37	4	15	1	3	68	7	0.5	1	0.1	29.9	35.8		
1800	7	957	15	31	4	2	0	24	4	7	2	2	26	7	0.7	1	0.1	29.8	34		
1900	3	658	22	19	6	2	0	13	9	12	0	1	65	13	1.7	3	0.4	31.9	37.1		
2000	2	494	5	18	3	0	0	14	9	4	0	1	100	24	4.4	7	1.3	35.4	40.7		
2100	1	342	1	15	0	1	0	5	7	3	0	0	91	28	7.5	3	0.8	36.9	41.6		
2200	2	154	1	15	1	0	0	3	13	7	0	0	54	19	9.7	3	1.5	37.7	43.2		
2300	2	95	0	13	0	0	0	4	12	2	0	0	42	13	10.2	1	0.8	38.3	43.8		
07-19	81	14457	349	1104	150	128	45	390	93	140	15	48	404	76	0.4	5	0	26.4	33.8		
06-22	95	16804	396	1255	170	139	47	447	128	168	16	52	776	168	0.9	19	0.1	27.4	34.9		
06-00	99	17053	397	1283	171	139	47	454	153	177	16	52	872	200	1	23	0.1	27.6	35.1		
00-00	104	17963	410	1439	176	151	48	476	163	193	16	53	1176	257	1.2	31	0.1	28.1	36		

Site
Location
Direction

1
A49 Winwick Road -N53.412624, W2.597562
Southbound

8551 / A49 Warrington
Mar-18
Automatic Traffic Count

Tuesday 20 March 2018

Time	Total	Classification												JPSL	JPSL%	JSL1 ACPO	JSL1%	JSL2 DfT	JSL2%	Mean	Vpp
		1 MCL	2 SV	3 SVT	4 TB2	5 TB3	6 T4	7 ART3	8 ART4	9 ART5	10 ART6	11 BD	12 DRT								
0000	101	3	70	0	12	0	0	0	3	5	8	0	0	29	28.7	13	12.9	2	2	37.8	43.6
0100	67	0	39	0	11	0	0	0	3	9	5	0	0	26	38.8	4	6	1	1.5	38.8	43.6
0200	56	0	36	0	8	2	0	0	2	3	5	0	0	24	42.9	5	8.9	1	1.8	39.6	44.1
0300	82	0	59	0	10	1	0	0	0	9	2	0	0	44	53.7	14	17.1	3	3.7	41.2	46.8
0400	99	2	72	1	14	0	0	0	3	5	2	0	0	36	36.4	11	11.1	2	2	39.4	44.5
0500	424	5	348	4	45	4	3	0	9	3	3	0	0	213	50.2	49	11.6	5	1.2	40.1	45
0600	1060	4	896	10	78	9	10	1	33	9	9	1	0	506	47.7	136	12.8	9	0.8	40	45.2
0700	1818	9	1512	43	114	20	21	3	61	8	18	1	8	257	14.1	44	2.4	4	0.2	32.8	39.8
0800	1683	15	1402	46	61	28	27	9	67	4	18	4	2	6	0.4	2	0.1	0	0	19.4	24.8
0900	1581	8	1300	36	103	30	18	6	43	9	17	7	4	91	5.8	9	0.6	1	0.1	24.9	36.5
1000	1271	7	1042	20	125	15	7	4	29	9	11	1	1	172	13.5	24	1.9	2	0.2	32.7	39.4
1100	1327	6	1104	16	128	11	9	1	22	14	11	0	5	123	9.3	13	1	1	0.1	31	38.5
1200	1301	8	1055	18	138	14	13	4	22	15	9	0	5	152	11.7	27	2.1	2	0.2	31.6	38.9
1300	1260	2	1050	19	113	8	12	3	21	15	14	1	2	177	14	17	1.3	0	0	31.3	39.6
1400	1274	7	1004	27	134	13	15	3	25	22	15	1	8	177	13.9	25	2	2	0.2	31.5	39.6
1500	1306	5	1061	20	136	18	16	3	17	15	9	2	4	202	15.5	35	2.7	4	0.3	32.5	40
1600	1318	8	1121	21	98	14	10	0	31	7	5	1	2	248	18.8	35	2.7	4	0.3	33.3	40.7
1700	1389	8	1230	16	74	7	8	2	25	7	5	0	7	238	17.1	55	4	6	0.4	33	40.5
1800	1292	13	1147	11	70	10	3	0	21	7	6	0	4	186	14.4	37	2.9	3	0.2	32.3	39.6
1900	1007	2	912	14	44	4	4	1	10	8	7	0	1	172	17.1	29	2.9	3	0.3	33.3	40.3
2000	632	4	571	9	22	3	0	0	4	13	4	0	2	138	21.8	30	4.7	5	0.8	34.4	41.2
2100	434	1	381	3	27	1	3	0	7	5	5	1	0	94	21.7	26	6	3	0.7	35.1	41.4
2200	364	2	307	3	21	0	0	1	5	17	7	1	0	109	29.9	33	9.1	4	1.1	37.4	42.9
2300	192	2	146	2	16	1	0	0	9	9	6	0	1	63	32.8	17	8.9	2	1	38.2	43.2
07-19	16820	96	14028	293	1294	188	159	38	384	132	138	18	52	2029	12.1	323	1.9	29	0.2	30.3	39.1
06-22	19953	107	16788	329	1465	205	176	40	438	167	163	20	55	2939	14.7	544	2.7	49	0.2	31.2	39.8
06-00	20509	111	17241	334	1502	206	176	41	452	193	176	21	56	3111	15.2	594	2.9	55	0.3	31.4	39.8
00-00	21338	121	17865	339	1602	213	180	41	472	227	201	21	56	3483	16.3	690	3.2	69	0.3	31.7	40.3

Site
Location
Direction

1
A49 Winwick Road -N53.412624, W2.597562
Southbound

8551 / A49 Warrington
Mar-18
Automatic Traffic Count

Wednesday 21 March 2018

Time	Total	Classification												JPSL	JPSL%	JSL1 ACPO	JSL1%	JSL2 DfT	JSL2%	Mean	Vpp
		1 MCL	2 SV	3 SVT	4 TB2	5 TB3	6 T4	7 ART3	8 ART4	9 ART5	10 ART6	11 BD	12 DRT								
0000	86	1	63	0	8	0	0	0	1	10	3	0	0	32	37.2	11	12.8	0	0	38.8	45.2
0100	65	0	39	0	10	0	0	0	2	6	8	0	0	22	33.8	5	7.7	0	0	38.7	41.8
0200	54	0	34	0	9	0	0	0	0	6	5	0	0	18	33.3	6	11.1	1	1.9	39.5	43.8
0300	78	0	56	1	13	2	0	0	1	4	1	0	0	28	35.9	8	10.3	1	1.3	39.2	44.1
0400	92	0	59	1	18	1	0	0	2	6	4	0	0	37	40.2	13	14.1	1	1.1	39.7	45.2
0500	399	7	328	6	32	5	6	0	6	4	5	0	0	204	51.1	57	14.3	5	1.3	40.6	45.6
0600	1061	8	888	12	88	7	12	3	27	2	11	1	2	532	50.1	149	14	7	0.7	40.4	45.6
0700	1806	6	1491	56	122	18	18	3	58	14	9	6	5	263	14.6	47	2.6	1	0.1	33.3	39.8
0800	1735	14	1438	51	78	21	20	7	73	5	16	2	10	14	0.8	1	0.1	0	0	21.8	29.1
0900	1605	8	1318	30	116	20	20	6	51	7	14	7	8	113	7	12	0.7	0	0	28	36.7
1000	1585	7	1271	22	141	15	15	3	46	14	25	10	16	79	5	11	0.7	1	0.1	29.2	36.7
1100	1488	9	1172	22	160	18	18	2	28	25	21	3	10	64	4.3	10	0.7	0	0	28.5	36.5
1200	1487	4	1218	25	144	12	11	10	31	9	11	4	8	100	6.7	23	1.5	1	0.1	29.2	37.1
1300	1404	6	1170	19	117	14	12	7	32	9	15	0	3	147	10.5	18	1.3	0	0	31	38.7
1400	1405	8	1156	14	137	14	13	3	26	17	11	2	4	152	10.8	19	1.4	1	0.1	30.7	38.7
1500	1321	3	1105	14	121	13	12	4	22	11	10	2	4	157	11.9	23	1.7	2	0.2	31.5	39.1
1600	1345	6	1155	22	89	6	6	5	29	9	14	1	3	223	16.6	32	2.4	0	0	32.4	40.3
1700	1267	7	1146	15	48	5	5	2	23	5	6	1	4	229	18.1	39	3.1	1	0.1	33.3	40.5
1800	1303	10	1156	14	68	10	3	1	27	7	4	1	2	110	8.4	17	1.3	4	0.3	31.1	37.8
1900	1005	5	905	9	45	7	5	1	13	9	3	1	2	101	10	21	2.1	2	0.2	31.4	38.5
2000	661	2	606	4	28	1	0	0	5	6	7	0	2	89	13.5	16	2.4	3	0.5	33.9	39.6
2100	426	0	378	6	19	2	2	0	3	10	5	0	1	76	17.8	19	4.5	2	0.5	34.7	40.7
2200	358	2	305	4	17	1	0	0	7	15	5	0	2	118	33	31	8.7	4	1.1	37.6	43.4
2300	220	0	179	1	19	1	1	0	5	10	4	0	0	85	38.6	25	11.4	10	4.5	39.1	44.3
07-19	17751	88	14796	304	1341	166	153	53	446	132	156	39	77	1651	9.3	252	1.4	11	0.1	29.8	38
06-22	20904	103	17573	335	1521	183	172	57	494	159	182	41	84	2449	11.7	457	2.2	25	0.1	30.7	38.9
06-00	21482	105	18057	340	1557	185	173	57	506	184	191	41	86	2652	12.3	513	2.4	39	0.2	30.9	39.1
00-00	22256	113	18636	348	1647	193	180	57	518	220	217	41	86	2993	13.4	613	2.8	47	0.2	31.2	39.4

Site
Location
Direction

1
A49 Winwick Road -N53.412624, W2.597562
Southbound

8551 / A49 Warrington
Mar-18
Automatic Traffic Count

Thursday 22 March 2018

Time	Total	Classification												JPSL 40	JPSL% 40	JSL1 46 ACPO	JSL1% 46 ACPO	JSL2 55 DfT	JSL2% 55 DfT	Mean	Vpp 85
		1 MCL	2 SV	3 SVT	4 TB2	5 TB3	6 T4	7 ART3	8 ART4	9 ART5	10 ART6	11 BD	12 DRT								
0000	104	2	82	0	8	0	0	0	0	6	5	0	1	54	51.9	16	15.4	2	1.9	40.4	45.6
0100	66	1	45	0	7	1	0	0	0	7	3	0	0	27	40.9	12	18.2	2	3	40	46.3
0200	47	1	27	0	8	0	0	0	0	1	5	0	0	19	40.4	5	10.6	0	0	39.2	43.6
0300	73	2	45	0	16	0	1	0	0	5	2	0	0	33	45.2	10	13.7	2	2.7	39.9	45
0400	111	0	79	0	20	1	0	0	0	5	2	0	0	43	38.7	12	10.8	0	0	39.5	44.3
0500	424	8	350	4	34	5	2	0	0	7	4	1	1	232	54.7	60	14.2	10	2.4	40.7	45.6
0600	1106	7	925	15	90	6	7	1	33	6	11	1	4	527	47.6	119	10.8	11	1	40	44.7
0700	1830	9	1505	53	105	16	23	7	59	14	24	1	14	237	13	25	1.4	2	0.1	32.8	39.4
0800	1806	12	1494	51	89	13	21	8	73	7	23	4	11	18	1	4	0.2	0	0	23.3	31.3
0900	1601	9	1347	23	115	24	18	6	28	11	13	1	6	88	5.5	8	0.5	1	0.1	26.3	36.2
1000	1363	6	1122	15	134	10	16	3	31	4	19	1	2	150	11	19	1.4	2	0.1	31.5	38.7
1100	1348	4	1104	18	136	18	14	3	24	8	12	2	5	167	12.4	17	1.3	0	0	32.2	39.1
1200	1352	13	1116	13	125	18	17	2	23	9	6	5	5	121	8.9	21	1.6	2	0.1	28.7	38
1300	1408	6	1176	17	118	16	18	3	30	5	13	3	3	159	11.3	18	1.3	1	0.1	31.5	38.7
1400	1421	7	1161	28	127	14	12	2	28	27	9	3	3	185	13	26	1.8	5	0.4	32	39.4
1500	1303	6	1085	16	122	10	15	2	21	7	12	3	4	175	13.4	20	1.5	0	0	32.1	39.4
1600	1381	11	1194	17	93	6	9	0	21	4	17	2	7	180	13	32	2.3	7	0.5	32.2	39.1
1700	1401	6	1245	23	73	8	7	1	21	7	5	2	3	241	17.2	38	2.7	3	0.2	32.7	40.3
1800	1263	11	1128	11	56	7	6	0	23	8	7	2	4	182	14.4	41	3.2	4	0.3	32.4	39.8
1900	1003	6	893	11	52	4	4	1	12	9	8	1	2	105	10.5	14	1.4	1	0.1	31.7	38.5
2000	708	1	631	3	34	6	3	0	6	12	12	0	0	140	19.8	29	4.1	5	0.7	34	41.2
2100	437	1	390	4	20	4	2	0	4	5	5	0	2	82	18.8	12	2.7	2	0.5	34.7	40.7
2200	360	5	305	3	16	3	0	0	5	13	8	1	1	78	21.7	18	5	2	0.6	36.6	41.2
2300	204	0	175	1	8	1	0	0	8	7	4	0	0	60	29.4	17	8.3	4	2	38.3	42.5
07-19	17477	100	14677	285	1293	160	176	37	382	111	160	29	67	1903	10.9	269	1.5	27	0.2	30.4	38.7
06-22	20731	115	17516	318	1489	180	192	39	437	143	196	31	75	2757	13.3	443	2.1	46	0.2	31.2	39.4
06-00	21295	120	17996	322	1513	184	192	39	450	163	208	32	76	2895	13.6	478	2.2	52	0.2	31.4	39.4
00-00	22120	134	18624	326	1606	191	195	39	467	198	229	33	78	3303	14.9	593	2.7	68	0.3	31.7	39.8

Site
Location
Direction

1
A49 Winwick Road -N53.412624, W2.597562
Southbound

8551 / A49 Warrington
Mar-18
Automatic Traffic Count

Friday 23 March 2018

Time	Total	Classification												JPSL 40	JPSL% 40	JSL1 46 ACPO	JSL1% 46 ACPO	JSL2 55 DfT	JSL2% 55 DfT	Mean	Vpp 85
		1 MCL	2 SV	3 SVT	4 TB2	5 TB3	6 T4	7 ART3	8 ART4	9 ART5	10 ART6	11 BD	12 DRT								
0000	98	2	64	0	17	0	0	0	1	8	6	0	0	30	30.6	6	6.1	1	1	37.7	41.8
0100	67	1	45	0	8	0	0	0	5	5	3	0	0	23	34.3	4	6	0	0	38.3	43.4
0200	66	1	37	1	11	1	1	1	1	8	4	0	0	24	36.4	3	4.5	0	0	38.4	42.9
0300	60	0	47	0	7	0	0	0	1	4	1	0	0	28	46.7	6	10	0	0	39.6	44.5
0400	95	1	73	0	13	0	0	0	2	2	4	0	0	35	36.8	11	11.6	1	1.1	39.3	44.1
0500	398	9	324	5	33	5	6	0	8	3	4	0	1	180	45.2	52	13.1	8	2	40.1	45.2
0600	1057	6	859	16	102	7	18	1	18	8	20	0	2	493	46.6	113	10.7	9	0.9	39.7	44.7
0700	1827	8	1484	51	124	25	19	9	68	9	26	1	3	225	12.3	33	1.8	1	0.1	31.5	39.1
0800	1847	8	1529	33	134	16	22	6	52	7	24	6	10	75	4.1	9	0.5	0	0	29.2	36
0900	1510	7	1233	21	135	18	16	7	42	7	15	2	7	177	11.7	18	1.2	0	0	31.2	38.9
1000	1338	6	1079	16	153	13	13	3	18	15	16	2	4	156	11.7	24	1.8	1	0.1	31.9	38.9
1100	1395	12	1155	18	134	11	18	3	21	9	12	1	1	160	11.5	30	2.2	1	0.1	31.4	38.7
1200	1420	9	1188	21	130	8	16	4	22	11	9	0	2	108	7.6	19	1.3	2	0.1	30.3	37.6
1300	1471	8	1232	19	129	15	12	8	24	7	11	2	4	166	11.3	20	1.4	4	0.3	30.5	38.9
1400	1396	6	1157	12	113	18	21	4	32	8	18	2	5	109	7.8	13	0.9	3	0.2	28.8	37.8
1500	1400	9	1173	23	110	17	14	2	26	13	8	3	2	186	13.3	27	1.9	3	0.2	31.9	39.4
1600	1304	11	1125	19	71	8	6	5	33	9	8	1	8	230	17.6	42	3.2	4	0.3	32.5	40.7
1700	1395	10	1256	10	62	6	7	1	22	10	8	0	3	237	17	43	3.1	3	0.2	33	40.3
1800	1430	4	1285	25	52	9	9	5	28	3	8	1	1	134	9.4	26	1.8	1	0.1	30.9	38.3
1900	1082	5	961	15	54	4	4	0	19	12	8	0	0	126	11.6	37	3.4	3	0.3	31.8	38.9
2000	698	4	628	4	30	3	2	0	7	10	9	0	1	126	18.1	30	4.3	2	0.3	34.4	40.5
2100	507	1	457	3	25	2	0	0	7	7	4	0	1	126	24.9	22	4.3	2	0.4	35.9	42.3
2200	436	6	385	1	16	1	1	0	4	12	8	1	1	141	32.3	22	5	4	0.9	37.3	42.3
2300	287	1	247	0	20	2	0	0	6	9	2	0	0	75	26.1	14	4.9	2	0.7	36.8	41.8
07-19	17733	98	14896	268	1347	164	173	57	388	108	163	21	50	1963	11.1	304	1.7	23	0.1	31	38.7
06-22	21077	114	17801	306	1558	180	197	58	439	145	204	21	54	2834	13.4	506	2.4	39	0.2	31.7	39.4
06-00	21800	121	18433	307	1594	183	198	58	449	166	214	22	55	3050	14	542	2.5	45	0.2	31.9	39.6
00-00	22584	135	19023	313	1683	189	205	59	467	196	236	22	56	3370	14.9	624	2.8	55	0.2	32.2	39.8

Site
Location
Direction

1
A49 Winwick Road -N53.412624, W2.597562
Southbound

8551 / A49 Warrington
Mar-18
Automatic Traffic Count

Saturday 24 March 2018

Time	Total	Classification												JPSL 40	JPSL% 40	JSL1 46 ACPO	JSL1% 46 ACPO	JSL2 55 DfT	JSL2% 55 DfT	Mean	Vpp 85
		1 MCL	2 SV	3 SVT	4 TB2	5 TB3	6 T4	7 ART3	8 ART4	9 ART5	10 ART6	11 BD	12 DRT								
0000	177	1	156	0	6	1	2	1	2	2	5	1	0	40	22.6	10	5.6	0	37.2	41.4	
0100	120	1	93	0	6	0	0	0	2	9	8	0	1	39	32.5	9	7.5	1	38.1	43.4	
0200	82	0	62	1	9	0	0	0	1	5	4	0	0	28	34.1	8	9.8	2	38.5	44.5	
0300	90	0	67	0	13	1	0	0	2	4	2	1	0	40	44.4	11	12.2	1	39	43.8	
0400	109	1	84	1	18	1	0	0	0	4	0	0	0	33	30.3	10	9.2	0	38.3	42.7	
0500	215	1	182	0	23	2	0	0	1	6	0	0	0	82	38.1	20	9.3	5	39.1	43.6	
0600	385	3	324	2	43	2	2	1	7	0	1	0	0	182	47.3	44	11.4	5	40.4	44.7	
0700	602	0	507	11	65	1	3	1	9	2	2	1	0	265	44	71	11.8	7	39.7	44.5	
0800	1092	4	961	14	66	6	6	1	23	4	6	0	1	247	22.6	55	5	35.4	41.4		
0900	1238	2	1098	22	67	7	10	0	24	3	5	0	0	228	18.4	30	2.4	3	33.3	40.5	
1000	1459	7	1309	19	58	16	9	2	27	3	6	0	3	170	11.7	32	2.2	3	31.2	39.1	
1100	1539	10	1405	17	48	7	10	1	22	5	10	1	3	98	6.4	15	1	2	29.7	37.4	
1200	1504	14	1351	24	48	17	9	2	24	3	5	0	7	104	6.9	16	1.1	1	28.6	37.6	
1300	1499	14	1377	16	48	5	9	2	18	6	3	0	1	138	9.2	28	1.9	4	30	38	
1400	1385	10	1286	13	39	7	7	1	16	1	2	0	3	128	9.2	21	1.5	2	29.5	38.3	
1500	1400	14	1296	16	44	3	5	3	9	5	2	0	3	130	9.3	24	1.7	2	29.5	37.8	
1600	1255	5	1151	21	40	5	8	1	16	1	5	0	2	179	14.3	35	2.8	1	31.5	39.6	
1700	1190	7	1090	11	42	6	6	0	16	2	6	0	4	188	15.8	43	3.6	3	32.2	40.3	
1800	1102	5	1014	7	45	3	5	1	14	3	5	0	0	192	17.4	28	2.5	2	32.7	40.5	
1900	825	2	764	7	33	3	1	0	13	0	2	0	0	154	18.7	32	3.9	5	34.1	40.9	
2000	550	2	519	4	13	2	0	0	6	1	2	0	1	101	18.4	18	3.3	3	34.5	40.7	
2100	456	2	433	4	12	1	0	0	2	2	0	0	0	120	26.3	19	4.2	5	36.6	42.5	
2200	344	0	329	0	14	1	0	0	0	0	0	0	0	90	26.2	22	6.4	5	37.5	41.4	
2300	287	0	262	3	17	0	0	0	5	0	0	0	0	89	31	19	6.6	1	38	41.8	
07-19	15265	92	13845	191	610	83	87	15	218	38	57	2	27	2067	13.5	398	2.6	35	31.4	39.4	
06-22	17481	101	15885	208	711	91	90	16	246	41	62	2	28	2624	15	511	2.9	53	31.9	39.8	
06-00	18112	101	16476	211	742	92	90	16	251	41	62	2	28	2803	15.5	552	3	59	32.1	40	
00-00	18905	105	17120	213	817	97	92	17	259	71	81	4	29	3065	16.2	620	3.3	68	32.4	40.3	

Site
Location
Direction

1
A49 Winwick Road -N53.412624, W2.597562
Southbound

8551 / A49 Warrington
Mar-18
Automatic Traffic Count

Sunday 25 March 2018

Time	Total	Classification												JPSL 40	JPSL% 40	JSL1 46 ACPO	JSL1% 46 ACPO	JSL2 55 DfT	JSL2% 55 DfT	Mean	Vpp 85	
		1 MCL	2 SV	3 SVT	4 TB2	5 TB3	6 T4	7 ART3	8 ART4	9 ART5	10 ART6	11 BD	12 DRT									
0000	205	0	188	2	11	2	0	0	0	0	0	0	0	0	87	42.4	15	7.3	1	0.5	39.2	43.4
0100	121	2	96	0	19	0	0	0	0	1	2	1	2	1	55	45.5	15	12.4	1	0.8	40.1	45
0200	111	0	104	0	6	0	0	0	0	0	1	0	0	0	51	45.9	12	10.8	2	1.8	39.7	44.1
0300	94	0	86	0	4	1	0	0	0	0	2	1	0	0	42	44.7	11	11.7	0	0	39.7	44.5
0400	123	2	115	0	4	0	0	0	0	0	2	0	0	0	60	48.8	20	16.3	3	2.4	40.4	46.1
0500	210	0	186	1	14	3	0	0	0	3	3	0	0	0	107	51	29	13.8	3	1.4	40.5	45.2
0600	318	1	285	2	22	0	0	0	0	3	1	4	0	0	167	52.5	59	18.6	6	1.9	41.2	46.8
0700	365	1	329	3	24	2	1	1	0	0	3	1	0	0	173	47.4	41	11.2	2	0.5	39.6	44.7
0800	654	2	597	7	29	3	1	0	0	11	3	1	0	0	257	39.3	75	11.5	9	1.4	39.2	44.5
0900	1095	6	1004	10	47	2	1	1	1	15	1	5	1	2	301	27.5	69	6.3	11	1	35.7	42.5
1000	1435	12	1317	25	37	8	5	0	0	19	0	9	0	3	138	9.6	22	1.5	2	0.1	30.7	38.7
1100	1421	15	1300	24	41	7	6	2	2	19	2	2	0	3	124	8.7	18	1.3	1	0.1	29.9	37.8
1200	1532	17	1420	14	34	7	8	1	1	25	2	3	0	1	112	7.3	27	1.8	1	0.1	28.7	37.4
1300	1331	10	1243	15	29	4	5	1	1	14	1	4	1	4	129	9.7	26	2	3	0.2	29.4	38.7
1400	1352	16	1265	14	32	6	2	0	0	13	1	2	0	1	179	13.2	32	2.4	4	0.3	31.1	39.4
1500	1010	13	914	20	31	4	2	0	0	18	3	4	0	1	239	23.7	57	5.6	10	1	34.8	41.6
1600	901	13	816	14	35	1	5	1	1	11	1	4	0	0	240	26.6	65	7.2	9	1	35.4	42.3
1700	802	11	744	6	23	1	1	0	0	11	2	3	0	0	301	37.5	90	11.2	13	1.6	38.3	44.5
1800	735	4	669	8	34	3	1	0	0	11	1	1	1	2	205	27.9	49	6.7	5	0.7	36.1	42.7
1900	531	5	502	4	13	2	1	0	0	2	1	1	0	0	140	26.4	37	7	5	0.9	36.1	42.3
2000	352	0	325	1	12	1	2	0	0	6	1	4	0	0	105	29.8	18	5.1	1	0.3	36.4	42.1
2100	228	2	214	0	7	0	0	0	0	3	1	1	0	0	93	40.8	32	14	9	3.9	39.6	45.4
2200	144	0	136	0	5	0	0	0	0	1	0	2	0	0	43	29.9	10	6.9	4	2.8	38.5	42.9
2300	87	2	78	0	5	0	0	0	0	0	0	2	0	0	28	32.2	4	4.6	0	0	37.9	43.4
07-19	12633	120	11618	160	396	48	38	7	7	167	20	39	3	17	2398	19	571	4.5	70	0.6	32.9	40.9
06-22	14062	128	12944	167	450	51	41	7	7	181	24	49	3	17	2903	20.6	717	5.1	91	0.6	33.4	41.4
06-00	14293	130	13158	167	460	51	41	7	7	182	24	53	3	17	2974	20.8	731	5.1	95	0.7	33.5	41.4
00-00	15157	134	13933	170	518	57	41	7	7	188	34	55	3	17	3376	22.3	833	5.5	105	0.7	33.8	41.6

Site
Location
Direction

1
A49 Winwick Road -N53.412624, W2.597562
Southbound

8551 / A49 Warrington
Mar-18
Automatic Traffic Count

Monday 26 March 2018

Time	Total	Classification												JPSL	JPSL%	JSL1 ACPO	JSL1%	JSL2 DfT	JSL2%	Mean	Vpp	
		1 MCL	2 SV	3 SVT	4 TB2	5 TB3	6 T4	7 ART3	8 ART4	9 ART5	10 ART6	11 BD	12 DRT									
0000	48	0	43	0	4	0	0	0	1	0	0	0	0	0	27	56.3	9	18.8	1	2.1	41.5	85
0100	44	0	34	0	4	0	0	0	0	4	2	0	0	0	18	40.9	4	9.1	0	0	39	43.4
0200	55	1	44	0	8	0	0	0	1	0	1	0	0	0	23	41.8	7	12.7	0	0	40.6	45.2
0300	95	1	74	0	15	0	1	0	2	1	1	0	0	0	43	45.3	14	14.7	1	1.1	40.4	45.9
0400	403	6	343	2	26	7	1	0	10	4	3	0	1	213	52.9	48	11.9	4	1	40.2	45	
0500	985	6	814	11	92	15	10	2	21	7	7	0	0	417	42.3	95	9.6	7	0.7	39.3	44.5	
0600	1769	8	1502	34	100	14	18	5	52	5	18	5	8	204	11.5	21	1.2	0	0	31.5	39.1	
0700	1777	10	1479	48	90	16	23	5	71	8	16	5	6	12	0.7	2	0.1	0	0	21.4	29.3	
0800	1521	6	1243	30	134	13	22	4	45	6	15	1	2	116	7.6	15	1	0	0	27.9	37.4	
0900	1395	6	1113	23	153	17	14	2	30	9	19	2	7	196	14.1	21	1.5	2	0.1	31.6	39.6	
1000	1335	8	1088	16	155	7	13	1	22	12	11	0	2	134	10	22	1.6	0	0	30.9	38.5	
1100	1417	3	1206	16	108	17	15	2	25	8	13	3	1	123	8.7	16	1.1	1	0.1	30.1	38.3	
1200	1398	10	1157	25	126	9	8	4	36	7	12	2	2	128	9.2	12	0.9	3	0.2	29.6	38	
1300	1370	5	1155	21	110	14	12	0	27	6	12	1	7	132	9.6	19	1.4	2	0.1	30.7	38.5	
1400	1335	11	1127	13	107	22	5	3	26	5	12	1	3	224	16.8	32	2.4	2	0.1	32.3	40.3	
1500	1328	7	1161	13	97	6	4	1	26	2	7	1	3	200	15.1	38	2.9	2	0.2	33.1	39.8	
1600	1306	6	1141	23	76	8	6	2	30	6	4	1	3	290	22.2	56	4.3	5	0.4	34	41.4	
1700	1356	15	1199	18	71	6	5	2	25	6	8	0	1	205	15.1	29	2.1	3	0.2	32.7	40	
1800	1008	3	893	9	54	7	6	1	19	4	10	1	1	153	15.2	34	3.4	4	0.4	32.6	40	
1900	694	0	623	9	30	2	2	0	10	8	9	0	1	134	19.3	22	3.2	3	0.4	34.1	40.7	
2000	422	2	375	1	18	3	0	0	8	12	3	0	0	100	23.7	25	5.9	2	0.5	36.2	41.6	
2100	343	4	295	1	14	1	2	0	8	9	9	0	0	110	32.1	22	6.4	2	0.6	37.5	43.2	
2200	221	1	178	0	19	0	0	0	8	9	6	0	0	82	37.1	26	11.8	3	1.4	38.8	44.3	
2300	95	0	74	1	6	0	0	0	0	12	2	0	0	34	35.8	6	6.3	0	0	38.9	42.5	
07-19	16546	90	13962	255	1281	142	133	27	382	79	139	18	38	1913	11.6	296	1.8	24	0.1	30.3	38.9	
06-22	19774	104	16757	300	1443	162	155	32	460	113	178	23	47	2461	12.4	386	2	31	0.2	30.8	39.1	
06-00	20090	105	17009	301	1468	162	155	32	468	134	186	23	47	2577	12.8	418	2.1	34	0.2	30.9	39.4	
00-00	21720	119	18361	314	1617	184	167	34	503	150	200	23	48	3318	15.3	595	2.7	47	0.2	31.6	40	

1

A49 Winwick Road -N53.412624, W2.597562
Northbound

7 Day Average Northbound

Time	Total
0000	130
0100	84
0200	76
0300	79
0400	143
0500	351
0600	588
0700	930
0800	973
0900	1075
1000	1218
1100	1401
1200	1469
1300	1553
1400	1581
1500	1635
1600	1682
1700	1511
1800	1249
1900	918
2000	713
2100	535
2200	344
2300	197
07-19	16277
06-00	19571
00-00	20435

AAADT Factor 14.8169

5 Day Average Northbound

Time	Total
0000	99
0100	68
0200	65
0300	70
0400	148
0500	411
0600	694
0700	1110
0800	1096
0900	1130
1000	1212
1100	1372
1200	1426
1300	1527
1400	1584
1500	1693
1600	1818
1700	1662
1800	1373
1900	1007
2000	806
2100	611
2200	387
2300	203
07-19	17004
06-00	20712
00-00	21574

AAAWT Factor 15.0174

1

A49 Winwick Road -N53.412624, W2.597562
Southbound

7 Day Average Southbound

Time	Total
0000	117
0100	79
0200	67
0300	82
0400	147
0500	436
0600	965
0700	1432
0800	1477
0900	1432
1000	1398
1100	1419
1200	1428
1300	1392
1400	1367
1500	1295
1600	1259
1700	1257
1800	1162
1900	878
2000	575
2100	404
2200	318
2300	196
07-19	16318
06-00	19654
00-00	20583

AAADT Factor 13.3655

5 Day Average Northbound

Time	Total
0000	87
0100	62
0200	56
0300	78
0400	160
0500	526
0600	1211
0700	1812
0800	1718
0900	1538
1000	1378
1100	1395
1200	1392
1300	1383
1400	1366
1500	1332
1600	1331
1700	1362
1800	1259
1900	958
2000	624
2100	429
2200	348
2300	200
07-19	17265
06-00	21035
00-00	22004

AAAWT Factor 13.6592

Appendix 2

ATC Data – A50

Warrington ATC K, A50

Produced by Road Data Services Ltd.

Channel 1 - Westbound

Vehicle Flow

Week 1

Hr Ending	30/03/2019 Saturday	31/03/2019 Sunday	01/04/2019 Monday	02/04/2019 Tuesday	03/04/2019 Wednesday	04/04/2019 Thursday	05/04/2019 Friday	5 Day Ave	7 Day Ave
1	84	82	40	28	26	20	35	30	45
2	37	40	14	16	22	19	19	18	24
3	24	0	12	6	11	9	11	10	10
4	23	32	10	7	25	10	19	14	18
5	21	23	37	25	30	26	22	28	26
6	70	61	141	152	165	168	153	156	130
7	105	74	195	214	259	242	231	228	189
8	209	91	571	596	609	632	562	594	467
9	285	133	708	678	765	742	667	712	568
10	474	269	584	591	643	614	623	611	543
11	495	405	455	493	425	448	476	459	457
12	566	482	402	492	448	482	523	469	485
13	532	553	514	481	536	481	553	513	521
14	551	494	482	463	487	491	504	485	496
15	483	462	486	468	476	488	520	488	483
16	500	399	584	626	543	590	647	598	556
17	447	283	743	731	747	740	719	736	630
18	432	324	707	723	703	669	684	697	606
19	378	327	635	643	661	642	645	645	562
20	269	251	328	357	325	350	322	336	315
21	206	165	223	225	241	236	214	228	216
22	163	138	170	193	190	195	185	187	176
23	117	97	109	121	113	125	152	124	119
24	111	58	46	60	53	45	89	59	66
7-19	5352	4222	6871	6985	7043	7019	7123	7008	6374
6-22	6095	4850	7787	7974	8058	8042	8075	7987	7269
6-24	6323	5005	7942	8155	8224	8212	8316	8170	7454
0-24	6582	5243	8196	8389	8503	8464	8575	8425	7707

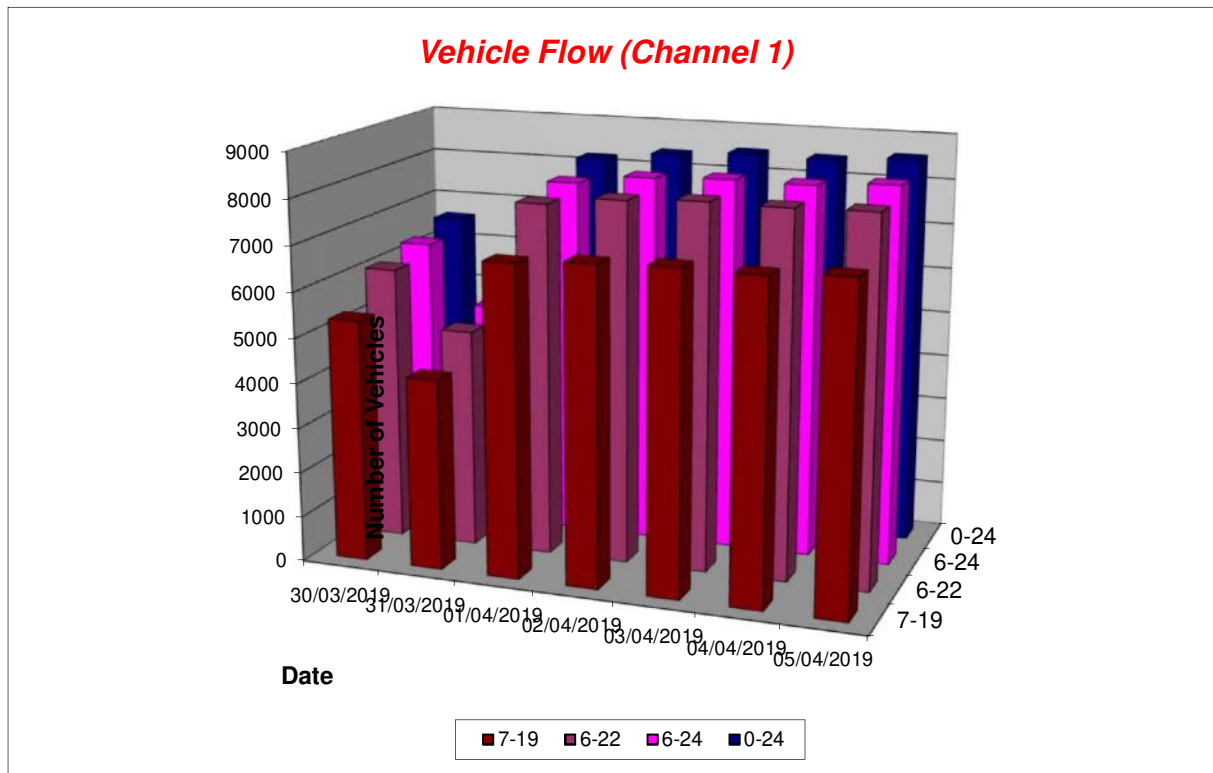

Warrington ATC K, A50

Produced by Road Data Services Ltd.

Channel 2 - Eastbound

Vehicle Flow

Week 1

Hr Ending	30/03/2019 Saturday	31/03/2019 Sunday	01/04/2019 Monday	02/04/2019 Tuesday	03/04/2019 Wednesday	04/04/2019 Thursday	05/04/2019 Friday	5 Day Ave	7 Day Ave
1	84	68	35	40	37	31	42	37	48
2	43	34	16	14	16	14	17	15	22
3	22	0	11	13	9	10	11	11	11
4	23	28	11	8	10	18	15	12	16
5	26	22	29	33	30	32	26	30	28
6	56	38	93	92	112	107	106	102	86
7	88	58	252	259	285	259	231	257	205
8	117	65	892	817	845	880	809	849	632
9	205	100	611	620	602	563	575	594	468
10	354	164	494	487	523	543	540	517	444
11	402	315	334	346	350	344	360	347	350
12	453	446	404	385	429	407	411	407	419
13	495	446	422	433	439	424	483	440	449
14	491	439	417	450	441	438	418	433	442
15	459	438	450	465	520	522	523	496	482
16	420	470	477	470	450	470	441	462	457
17	435	367	694	618	634	658	558	632	566
18	435	330	703	663	654	567	633	644	569
19	438	320	594	616	587	547	628	594	533
20	361	272	404	403	391	376	356	386	366
21	236	232	316	304	355	323	298	319	295
22	174	136	197	198	237	220	216	214	197
23	141	89	125	139	131	165	191	150	140
24	105	71	73	67	71	86	102	80	82
7-19	4704	3900	6492	6370	6474	6363	6379	6416	5812
6-22	5563	4598	7661	7534	7742	7541	7480	7592	6874
6-24	5809	4758	7859	7740	7944	7792	7773	7822	7096
0-24	6063	4948	8054	7940	8158	8004	7990	8029	7308

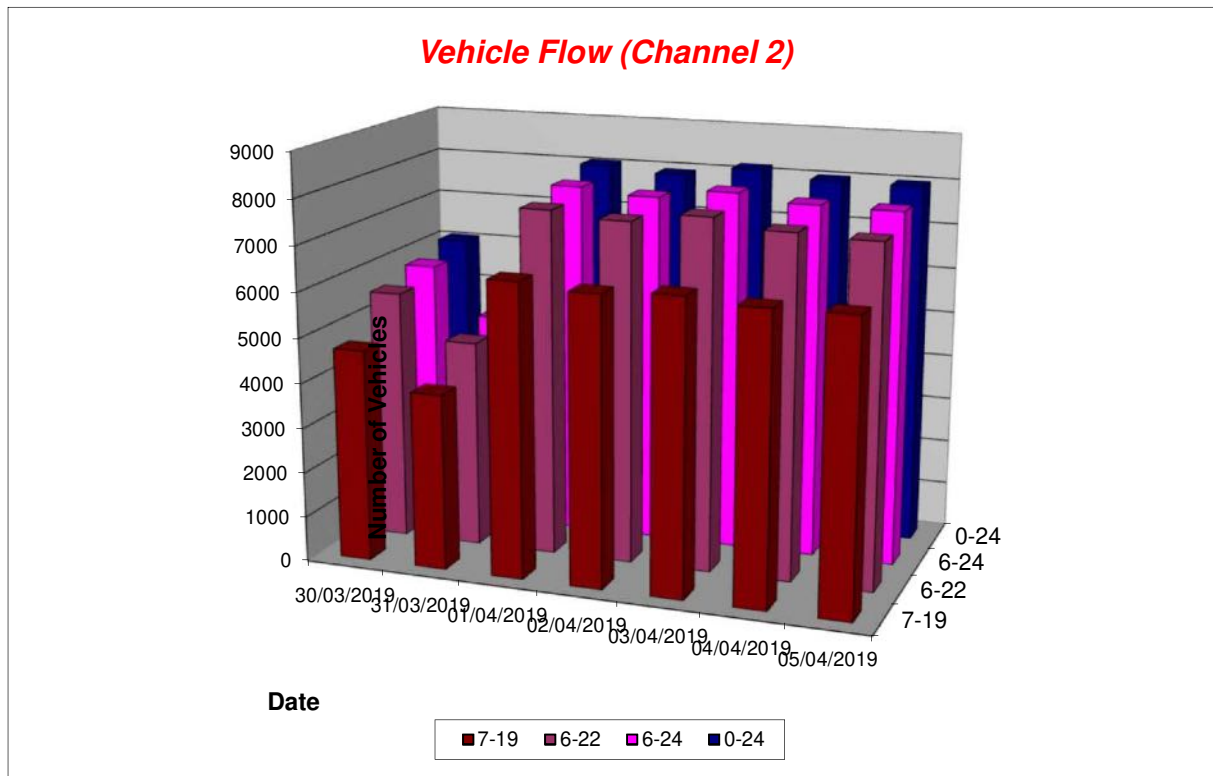

A50

Westbound

7 Day Average Westbound

Time	Total
0000	45
0100	24
0200	10
0300	18
0400	26
0500	130
0600	189
0700	467
0800	568
0900	543
1000	457
1100	485
1200	521
1300	496
1400	483
1500	556
1600	630
1700	606
1800	562
1900	315
2000	216
2100	176
2200	119
2300	66
07-19	6374
06-00	7454
00-00	7707

AADT Factor 10.9387

5 Day Average Westbound

Time	Total
0000	30
0100	18
0200	10
0300	14
0400	28
0500	156
0600	228
0700	594
0800	712
0900	611
1000	459
1100	469
1200	513
1300	485
1400	488
1500	598
1600	736
1700	697
1800	645
1900	336
2000	228
2100	187
2200	124
2300	59
07-19	7008
06-00	8170
00-00	8425

AAWT Factor 11.5949

A50

Eastbound

7 Day Average Eastbound

Time	Total
0000	48
0100	22
0200	11
0300	16
0400	28
0500	86
0600	205
0700	632
0800	468
0900	444
1000	350
1100	419
1200	449
1300	442
1400	482
1500	457
1600	566
1700	569
1800	533
1900	366
2000	295
2100	197
2200	140
2300	82
07-19	5812
06-00	7096
00-00	7308

AADT Factor 11.8045

5 Day Average Eastbound

Time	Total
0000	37
0100	15
0200	11
0300	12
0400	30
0500	102
0600	257
0700	849
0800	594
0900	517
1000	347
1100	407
1200	440
1300	433
1400	496
1500	462
1600	632
1700	644
1800	594
1900	386
2000	319
2100	214
2200	150
2300	80
07-19	6416
06-00	7822
00-00	8029

AAWT Factor 12.6338

Appendix 3

ATC Data – Poplars Avenue

Warrington ATC F, Poplars Avenue

Produced by Road Data Services Ltd.

Channel 1 - Westbound

Vehicle Flow

Week 1

Hr Ending	30/03/2019 Saturday	31/03/2019 Sunday	01/04/2019 Monday	02/04/2019 Tuesday	03/04/2019 Wednesday	04/04/2019 Thursday	05/04/2019 Friday	5 Day Ave	7 Day Ave
1	20	24	12	14	14	12	12	13	15
2	14	15	5	2	4	4	5	4	7
3	8	0	1	4	2	3	2	2	3
4	9	8	7	6	5	3	3	5	6
5	11	18	7	14	16	13	11	12	13
6	30	17	42	35	43	44	37	40	35
7	32	24	58	62	76	73	78	69	58
8	67	45	143	140	129	126	130	134	111
9	115	57	183	187	174	146	163	171	146
10	162	110	136	142	178	146	172	155	149
11	180	147	134	142	135	174	170	151	155
12	207	207	143	144	156	175	172	158	172
13	214	248	170	143	156	147	172	158	179
14	232	228	179	168	185	162	239	187	199
15	233	220	186	155	195	169	189	179	192
16	194	189	222	242	246	213	282	241	227
17	208	151	300	275	276	277	291	284	254
18	195	164	276	301	331	325	284	303	268
19	178	127	190	221	224	226	266	225	205
20	129	128	160	160	172	149	146	157	149
21	100	102	101	115	124	116	98	111	108
22	73	70	80	82	95	77	85	84	80
23	48	37	52	49	36	55	61	51	48
24	41	22	24	15	22	32	38	26	28
7-19	2185	1893	2262	2260	2385	2286	2530	2345	2257
6-22	2519	2217	2661	2679	2852	2701	2937	2766	2652
6-24	2608	2276	2737	2743	2910	2788	3036	2843	2728
0-24	2700	2358	2811	2818	2994	2867	3106	2919	2808

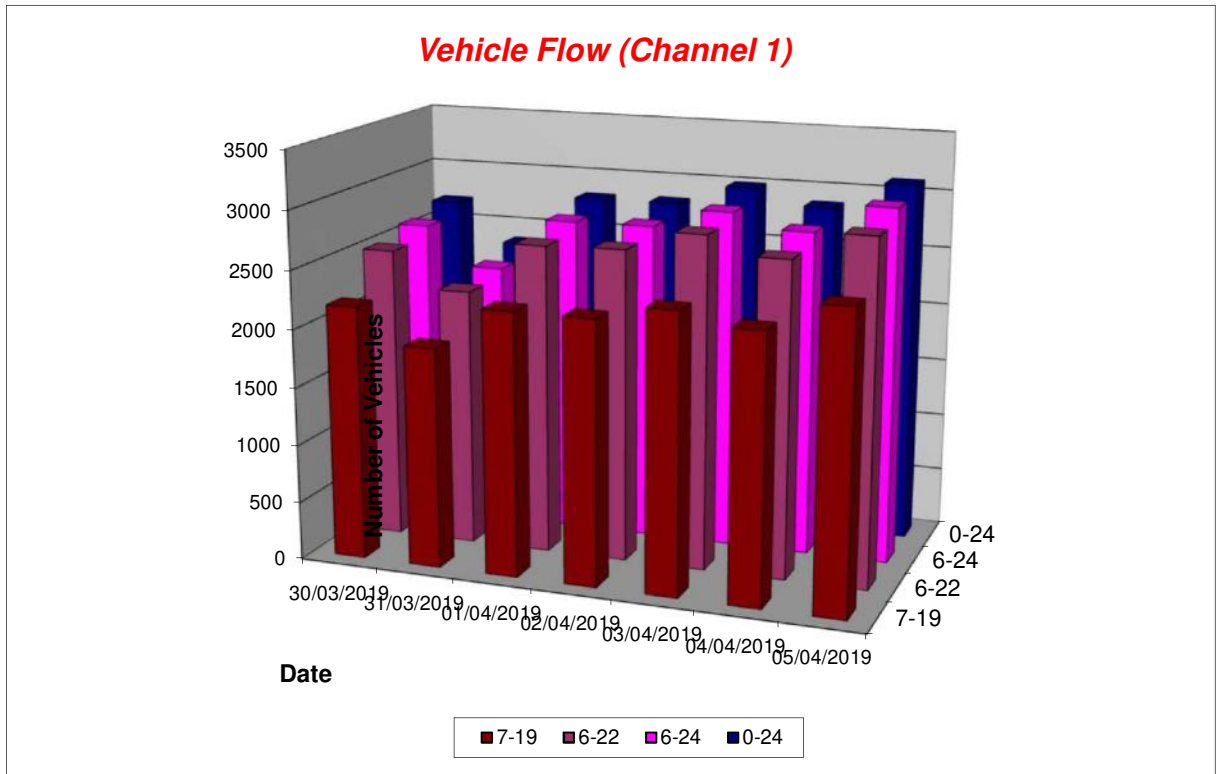

Warrington ATC F, Poplars Avenue

Produced by Road Data Services Ltd.

Channel 2 - Eastbound

Vehicle Flow

Week 1

Hr Ending	30/03/2019 Saturday	31/03/2019 Sunday	01/04/2019 Monday	02/04/2019 Tuesday	03/04/2019 Wednesday	04/04/2019 Thursday	05/04/2019 Friday	5 Day Ave	7 Day Ave
1	17	20	8	7	11	17	16	12	14
2	13	16	7	4	4	4	4	5	7
3	9	0	4	8	3	4	3	4	4
4	10	12	7	6	7	5	6	6	8
5	7	11	4	3	3	4	11	5	6
6	19	10	27	27	27	30	18	26	23
7	33	21	90	105	95	97	75	92	74
8	54	28	274	257	253	284	237	261	198
9	82	49	326	334	348	329	315	330	255
10	153	101	172	176	172	176	152	170	157
11	179	135	130	159	137	117	144	137	143
12	197	183	162	159	158	172	168	164	171
13	197	209	161	177	169	173	225	181	187
14	236	252	159	168	180	164	190	172	193
15	226	201	205	216	213	215	218	213	213
16	218	206	247	231	217	223	236	231	225
17	215	162	216	227	265	238	251	239	225
18	222	171	222	268	233	235	260	244	230
19	189	146	222	199	210	220	235	217	203
20	139	134	137	161	148	145	176	153	149
21	122	102	132	107	114	127	123	121	118
22	75	70	73	79	88	76	94	82	79
23	60	30	63	60	48	72	90	67	60
24	34	15	29	20	27	22	37	27	26
7-19	2168	1843	2496	2571	2555	2546	2631	2560	2401
6-22	2537	2170	2928	3023	3000	2991	3099	3008	2821
6-24	2631	2215	3020	3103	3075	3085	3226	3102	2908
0-24	2706	2284	3077	3158	3130	3149	3284	3160	2970

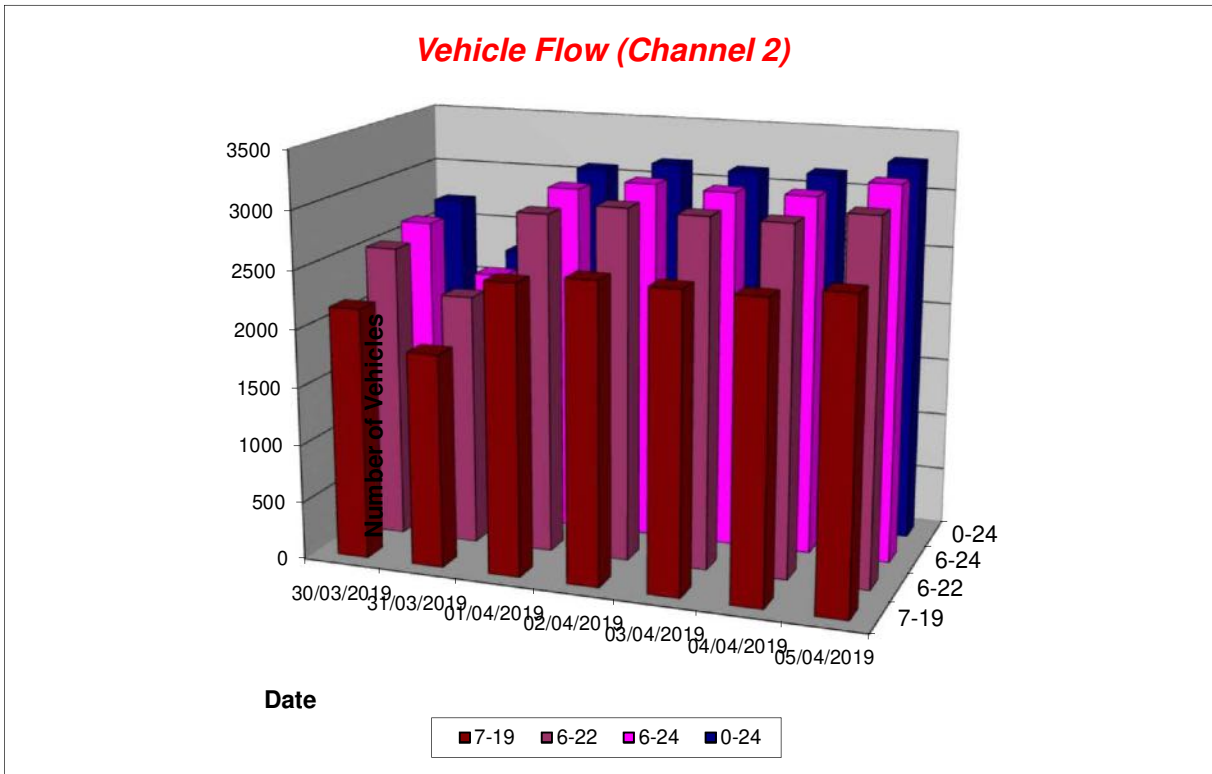

Poplars Avenue
Westbound

7 Day Average Westbound

Time	Total
0000	15
0100	7
0200	3
0300	6
0400	13
0500	35
0600	58
0700	111
0800	146
0900	149
1000	155
1100	172
1200	179
1300	199
1400	192
1500	227
1600	254
1700	268
1800	205
1900	149
2000	108
2100	80
2200	48
2300	28
07-19	2257
06-00	2728
00-00	2808

AAWT Factor 11.8469

5 Day Average Westbound

Time	Total
0000	13
0100	4
0200	2
0300	5
0400	12
0500	40
0600	69
0700	134
0800	171
0900	155
1000	151
1100	158
1200	158
1300	187
1400	179
1500	241
1600	284
1700	303
1800	225
1900	157
2000	111
2100	84
2200	51
2300	26
07-19	2345
06-00	2843
00-00	2919

AAWT Factor 11.9949

Poplars Avenue
Eastbound

7 Day Average Eastbound

Time	Total
0000	14
0100	7
0200	4
0300	8
0400	6
0500	23
0600	74
0700	198
0800	255
0900	157
1000	143
1100	171
1200	187
1300	193
1400	213
1500	225
1600	225
1700	230
1800	203
1900	149
2000	118
2100	79
2200	60
2300	26
07-19	2401
06-00	2908
00-00	2970

AAWT Factor 10.3474

5 Day Average Eastbound

Time	Total
0000	12
0100	5
0200	4
0300	6
0400	5
0500	26
0600	92
0700	261
0800	330
0900	170
1000	137
1100	164
1200	181
1300	172
1400	213
1500	231
1600	239
1700	244
1800	217
1900	153
2000	121
2100	82
2200	67
2300	27
07-19	2560
06-00	3102
00-00	3160

AAWT Factor 10.8077

Appendix 4

ATC Data – Blackbrook Avenue

Warrington ATC, Blackbrook Avenue

Produced by Road Data Services Ltd.

Channel 1 - Northbound

20/11/2015	Vehicle Classes													TOTAL
Hr Ending	1	2	3	4	5	6	7	8	9	10	11	12	13	
1	11	1	0	0	0	0	0	0	0	0	0	0	0	12
2	4	0	0	0	0	0	0	0	0	0	0	0	0	4
3	2	2	0	0	0	0	0	0	0	0	0	0	0	4
4	0	1	0	0	0	0	0	0	0	0	0	0	0	1
5	9	0	0	0	0	0	0	0	0	0	0	0	0	9
6	23	5	0	0	0	0	0	0	0	0	0	0	0	28
7	46	9	0	0	0	0	0	0	0	0	0	0	0	55
8	126	25	0	0	0	0	0	0	0	0	0	1	0	152
9	207	32	0	0	1	0	0	0	0	0	0	1	0	241
10	144	26	1	1	0	0	0	0	0	0	0	1	0	173
11	120	14	0	0	0	0	0	0	0	0	0	1	0	135
12	151	19	0	0	1	0	0	0	0	0	0	0	0	171
13	176	16	2	0	0	0	0	0	0	0	0	1	0	195
14	167	29	1	0	1	0	0	0	0	0	0	2	0	200
15	191	29	1	0	0	0	0	0	0	0	0	0	0	221
16	232	41	1	0	1	0	0	0	0	0	0	2	0	277
17	291	39	1	0	0	0	0	0	0	0	0	0	0	331
18	328	44	1	0	1	0	0	0	0	0	0	2	0	376
19	299	26	2	0	0	0	0	0	0	0	0	0	0	327
20	194	12	1	0	2	0	0	0	0	0	0	1	0	210
21	94	7	0	0	0	0	0	0	0	0	0	0	0	101
22	75	5	1	0	0	0	0	0	0	0	0	0	0	81
23	55	6	0	0	0	0	0	0	0	0	0	0	0	61
24	50	3	0	0	0	0	0	0	0	0	0	0	0	53
7-19	2432	340	10	1	5	0	0	0	0	0	0	11	0	2799
6-22	2841	373	12	1	7	0	0	0	0	0	0	12	0	3246
6-24	2946	382	12	1	7	0	0	0	0	0	0	12	0	3360
0-24	2995	391	12	1	7	0	0	0	0	0	0	12	0	3418

Channel 2 - Southbound

20/11/2015	Vehicle Classes													TOTAL
Hr Ending	1	2	3	4	5	6	7	8	9	10	11	12	13	
1	11	2	0	0	0	0	0	0	0	0	0	0	0	13
2	4	0	0	0	0	0	0	0	0	0	0	0	0	4
3	4	0	0	0	0	0	0	0	0	0	0	0	0	4
4	2	0	0	0	0	0	0	0	0	0	0	0	0	2
5	11	0	0	0	0	0	0	0	0	0	0	0	0	11
6	22	4	0	0	0	0	0	0	0	0	0	0	0	26
7	82	13	0	0	0	0	0	0	0	0	0	0	0	95
8	363	39	1	0	0	0	0	0	0	0	0	0	0	403
9	380	44	1	0	0	0	0	0	0	0	0	0	0	425
10	224	18	0	0	0	0	0	0	0	0	0	1	0	243
11	175	19	0	0	0	0	0	0	0	0	0	0	0	194
12	131	21	1	0	0	0	0	0	0	0	0	3	0	156
13	158	14	0	0	1	0	0	0	0	0	0	2	0	175
14	178	21	0	0	0	0	0	0	0	0	0	0	0	199
15	191	20	0	0	1	0	0	0	0	0	0	2	0	214
16	247	28	3	0	0	0	0	0	0	0	0	0	0	278
17	251	34	0	0	0	0	0	0	0	0	0	0	0	285
18	267	27	1	0	0	0	0	0	0	0	0	1	0	296
19	202	10	0	0	0	0	0	0	0	0	0	0	0	212
20	156	9	1	0	0	0	0	0	0	0	0	0	0	166
21	101	3	0	0	0	0	0	0	0	0	0	0	0	104
22	80	6	0	0	0	0	0	0	0	0	0	0	0	86
23	44	3	0	0	0	0	0	0	0	0	0	0	0	47
24	42	2	0	0	0	0	0	0	0	0	0	0	0	44
7-19	2767	295	7	0	2	0	0	0	0	0	0	9	0	3080
6-22	3186	326	8	0	2	0	0	0	0	0	0	9	0	3531
6-24	3272	331	8	0	2	0	0	0	0	0	0	9	0	3622
0-24	3326	337	8	0	2	0	0	0	0	0	0	9	0	3682

Warrington ATC, Blackbrook Avenue

Produced by Road Data Services Ltd.

Channel 1 - Northbound

21/11/2015	Vehicle Classes													TOTAL
Hr Ending	1	2	3	4	5	6	7	8	9	10	11	12	13	
1	26	1	0	0	0	0	0	0	0	0	0	0	0	27
2	8	0	0	0	0	0	0	0	0	0	0	0	0	8
3	7	0	0	0	0	0	0	0	0	0	0	0	0	7
4	6	1	0	0	0	0	0	0	0	0	0	0	0	7
5	5	0	0	0	0	0	0	0	0	0	0	0	0	5
6	8	1	0	0	0	0	0	0	0	0	0	0	0	9
7	17	1	0	0	0	0	0	0	0	0	0	0	0	18
8	35	4	0	0	0	0	0	0	0	0	0	0	0	39
9	54	9	1	0	0	0	0	0	0	0	0	0	0	64
10	103	13	1	0	0	0	0	0	0	0	0	1	0	118
11	162	26	0	0	0	0	0	0	0	0	0	0	0	188
12	218	17	0	0	0	0	0	0	0	0	0	0	0	235
13	198	30	0	0	0	0	0	1	0	0	0	0	0	229
14	186	14	0	0	0	0	0	1	0	0	0	1	0	202
15	181	23	0	0	0	0	0	0	0	0	0	0	0	204
16	192	18	1	0	0	0	0	0	0	0	0	1	0	212
17	187	11	0	0	0	0	0	0	0	0	0	0	0	198
18	185	9	0	0	0	0	0	0	0	0	0	0	0	194
19	147	10	0	0	0	0	0	0	0	0	0	0	0	157
20	102	7	0	0	0	0	0	0	0	0	0	0	0	109
21	84	8	0	0	0	0	0	0	0	0	0	0	0	92
22	60	1	0	0	0	0	0	0	0	0	0	0	0	61
23	55	1	0	0	0	0	0	0	0	0	0	0	0	56
24	52	5	1	0	0	0	0	0	0	0	0	0	0	58
7-19	1848	184	3	0	0	0	0	2	0	0	0	3	0	2040
6-22	2111	201	3	0	0	0	0	2	0	0	0	3	0	2320
6-24	2218	207	4	0	0	0	0	2	0	0	0	3	0	2434
0-24	2278	210	4	0	0	0	0	2	0	0	0	3	0	2497

Channel 2 - Southbound

21/11/2015	Vehicle Classes													TOTAL
Hr Ending	1	2	3	4	5	6	7	8	9	10	11	12	13	
1	21	1	0	0	0	0	0	0	0	0	0	0	0	22
2	13	1	0	0	0	0	0	0	0	0	0	0	0	14
3	4	1	0	0	0	0	0	0	0	0	0	0	0	5
4	3	0	0	0	0	0	0	0	0	0	0	0	0	3
5	4	0	0	0	0	0	0	0	0	0	0	0	0	4
6	10	2	0	0	0	0	0	0	0	0	0	0	0	12
7	29	4	0	0	0	0	0	0	0	0	0	0	0	33
8	51	3	0	0	0	0	0	0	0	0	0	0	0	54
9	120	14	0	0	0	0	0	0	0	0	0	0	0	134
10	166	17	0	0	1	0	0	0	0	0	0	0	0	184
11	199	14	0	0	0	0	0	0	0	0	0	0	0	213
12	206	12	0	0	0	0	0	0	0	0	0	0	0	218
13	187	8	0	0	0	0	0	0	0	0	0	0	0	195
14	191	10	0	1	0	0	0	1	0	0	0	0	0	203
15	206	14	0	0	0	0	0	0	0	0	0	0	0	220
16	178	12	0	0	0	0	0	0	0	0	0	0	0	190
17	189	12	0	0	0	0	0	0	1	0	0	0	0	202
18	161	8	0	0	0	0	0	0	0	0	0	0	0	169
19	112	1	0	0	0	0	0	0	0	0	0	0	0	113
20	123	4	0	0	0	0	0	0	0	0	0	0	0	127
21	81	4	0	0	0	0	0	0	0	0	0	0	0	85
22	64	1	0	0	0	0	0	0	0	0	0	0	0	65
23	54	0	0	0	0	0	0	0	0	0	0	0	0	54
24	49	3	0	0	0	0	0	0	0	0	0	0	0	52
7-19	1966	125	0	1	1	0	0	1	1	0	0	0	0	2095
6-22	2263	138	0	1	1	0	0	1	1	0	0	0	0	2405
6-24	2366	141	0	1	1	0	0	1	1	0	0	0	0	2511
0-24	2421	146	0	1	1	0	0	1	1	0	0	0	0	2571

Warrington ATC, Blackbrook Avenue

Produced by Road Data Services Ltd.

Channel 1 - Northbound

22/11/2015	Vehicle Classes													TOTAL
Hr Ending	1	2	3	4	5	6	7	8	9	10	11	12	13	
1	39	1	0	0	0	0	0	0	0	0	0	0	0	40
2	15	2	0	0	0	0	0	0	0	0	0	0	0	17
3	4	0	0	0	0	0	0	0	0	0	0	0	0	4
4	6	2	0	0	0	0	0	0	0	0	0	0	0	8
5	15	0	0	0	0	0	0	0	0	0	0	0	0	15
6	5	0	0	0	0	0	0	0	0	0	0	0	0	5
7	13	3	0	0	0	0	0	0	0	0	0	0	0	16
8	23	3	0	0	0	0	0	0	0	0	0	0	0	26
9	33	2	0	0	0	0	0	0	0	0	0	0	0	35
10	76	6	0	0	0	0	0	0	0	0	0	0	0	82
11	96	11	1	0	0	0	0	0	0	0	0	1	0	109
12	141	8	0	0	1	0	0	0	0	0	0	0	0	150
13	166	17	1	0	0	0	0	1	0	0	0	0	0	185
14	219	13	0	0	0	0	0	0	0	0	0	2	0	234
15	146	16	1	0	0	0	0	0	0	0	0	0	0	163
16	193	10	0	0	1	0	0	0	0	0	0	1	0	205
17	189	13	0	0	0	0	1	0	0	0	0	0	0	203
18	152	9	0	0	0	0	0	0	0	0	0	1	0	162
19	108	4	2	0	1	0	0	0	1	0	0	0	0	116
20	102	5	0	0	0	0	0	0	0	0	0	0	0	107
21	68	2	0	0	0	0	0	0	0	0	0	0	0	70
22	48	2	0	0	0	0	0	0	0	0	0	0	0	50
23	36	4	0	0	0	0	0	0	0	0	0	0	0	40
24	14	3	0	0	0	0	0	0	0	0	0	0	0	17
7-19	1542	112	5	0	3	0	1	1	1	0	0	5	0	1670
6-22	1773	124	5	0	3	0	1	1	1	0	0	5	0	1913
6-24	1823	131	5	0	3	0	1	1	1	0	0	5	0	1970
0-24	1907	136	5	0	3	0	1	1	1	0	0	5	0	2059

Channel 2 - Southbound

22/11/2015	Vehicle Classes													TOTAL
Hr Ending	1	2	3	4	5	6	7	8	9	10	11	12	13	
1	40	1	0	0	0	0	0	0	0	0	0	0	0	41
2	16	5	0	0	0	0	0	0	0	0	0	0	0	21
3	5	1	0	0	0	0	0	0	0	0	0	0	0	6
4	6	4	0	0	0	0	0	0	0	0	0	0	0	10
5	13	0	0	0	0	0	0	0	0	0	0	0	0	13
6	10	0	0	0	0	0	0	0	0	0	0	0	0	10
7	14	2	0	0	0	0	0	0	0	0	0	0	0	16
8	27	2	0	0	0	0	0	0	0	0	0	0	0	29
9	55	2	0	0	0	0	0	0	0	0	0	0	0	57
10	85	2	1	0	0	0	0	0	0	0	0	0	0	88
11	125	10	0	0	0	0	0	0	0	0	0	2	0	137
12	162	14	0	0	0	0	0	0	0	0	0	0	0	176
13	200	12	1	0	0	0	0	0	0	0	0	1	0	214
14	204	15	0	1	2	0	0	0	0	0	0	0	0	222
15	186	16	0	0	0	0	0	0	0	0	0	1	0	203
16	160	6	0	0	0	0	0	0	0	0	0	0	0	166
17	194	8	0	0	0	0	0	0	0	0	0	1	0	203
18	120	10	0	0	0	0	0	0	0	0	0	0	0	130
19	118	3	0	0	0	0	0	0	0	0	0	0	0	121
20	85	1	0	0	0	0	0	0	0	0	0	1	0	87
21	74	4	0	0	0	0	0	0	0	0	0	0	0	78
22	52	2	0	0	0	0	0	0	0	0	0	0	0	54
23	27	3	0	0	0	0	0	0	0	0	0	0	0	30
24	20	1	0	0	0	0	0	0	0	0	0	0	0	21
7-19	1636	100	2	1	2	0	0	0	0	0	0	5	0	1746
6-22	1861	109	2	1	2	0	0	0	0	0	0	6	0	1981
6-24	1908	113	2	1	2	0	0	0	0	0	0	6	0	2032
0-24	1998	124	2	1	2	0	0	0	0	0	0	6	0	2133

Warrington ATC, Blackbrook Avenue

Produced by Road Data Services Ltd.

Channel 1 - Northbound

23/11/2015	Vehicle Classes													TOTAL
Hr Ending	1	2	3	4	5	6	7	8	9	10	11	12	13	
1	3	4	0	0	0	0	0	0	0	0	0	0	0	7
2	2	2	0	0	0	0	0	0	0	0	0	0	0	4
3	2	0	0	0	0	0	0	0	0	0	0	0	0	2
4	2	1	0	0	0	0	0	0	0	0	0	0	0	3
5	6	0	0	0	0	0	0	0	0	0	0	0	0	6
6	27	2	0	0	0	0	0	0	0	0	0	1	0	30
7	36	3	0	0	0	0	0	0	0	0	0	1	0	40
8	135	28	0	0	0	0	0	0	0	0	0	1	0	164
9	214	29	1	0	1	0	0	0	0	0	0	1	0	246
10	109	24	1	0	0	0	0	0	1	0	0	0	0	135
11	101	16	0	0	0	0	0	0	0	0	0	1	0	118
12	127	16	0	0	0	0	0	0	0	0	0	1	0	144
13	149	17	0	0	0	0	0	0	0	0	0	0	0	166
14	122	23	0	0	1	0	0	0	0	0	0	1	0	147
15	143	25	0	0	0	0	0	0	0	0	0	0	0	168
16	264	33	0	0	1	0	0	0	0	0	0	0	0	298
17	268	48	0	0	0	0	0	0	1	0	0	0	0	317
18	259	31	2	0	0	0	0	0	1	0	0	2	0	295
19	198	18	0	0	0	0	0	0	0	0	0	0	0	216
20	122	8	0	0	0	0	0	0	0	0	0	0	0	130
21	94	8	0	0	0	0	0	0	0	0	0	0	0	102
22	64	2	0	0	0	0	0	0	0	0	0	0	0	66
23	46	5	0	0	0	0	0	0	0	0	0	0	0	51
24	13	0	0	0	0	0	0	0	0	0	0	0	0	13
7-19	2089	308	4	0	3	0	0	0	3	0	0	7	0	2414
6-22	2405	329	4	0	3	0	0	0	3	0	0	8	0	2752
6-24	2464	334	4	0	3	0	0	0	3	0	0	8	0	2816
0-24	2506	343	4	0	3	0	0	0	3	0	0	9	0	2868

Channel 2 - Southbound

23/11/2015	Vehicle Classes													TOTAL
Hr Ending	1	2	3	4	5	6	7	8	9	10	11	12	13	
1	5	1	0	0	0	0	0	0	0	0	0	0	0	6
2	2	0	0	0	0	0	0	0	0	0	0	0	0	2
3	2	0	0	0	0	0	0	0	0	0	0	0	0	2
4	1	0	0	0	0	0	0	0	0	0	0	0	0	1
5	4	1	0	0	0	0	0	0	0	0	0	0	0	5
6	22	3	0	0	0	0	0	0	0	0	0	1	0	26
7	80	13	0	0	0	0	0	0	0	0	0	0	0	93
8	353	46	2	0	2	0	0	0	0	0	0	0	0	403
9	438	34	2	1	1	0	0	0	0	0	0	1	0	477
10	247	32	1	0	0	0	0	1	2	0	0	0	0	283
11	157	16	0	0	0	0	0	0	0	0	0	0	0	173
12	150	22	0	1	0	0	0	0	0	0	0	3	0	176
13	155	14	0	0	0	0	0	0	0	0	0	2	0	171
14	196	26	1	0	0	0	0	0	1	0	0	0	0	224
15	196	29	1	0	0	0	0	1	1	0	0	1	0	229
16	180	17	1	0	0	0	0	0	0	0	0	0	0	198
17	231	36	0	0	0	0	0	0	0	0	0	1	0	268
18	272	23	2	0	0	0	0	0	0	0	0	1	0	298
19	188	12	0	0	0	0	0	0	0	0	0	0	0	200
20	134	2	0	0	0	0	0	0	0	0	0	0	0	136
21	80	7	0	0	0	0	0	0	0	0	0	0	0	87
22	59	2	0	0	0	0	0	0	0	0	0	0	0	61
23	35	6	0	0	0	0	0	0	0	0	0	0	0	41
24	15	1	0	0	0	0	0	0	0	0	0	0	0	16
7-19	2763	307	10	2	3	0	0	2	4	0	0	9	0	3100
6-22	3116	331	10	2	3	0	0	2	4	0	0	9	0	3477
6-24	3166	338	10	2	3	0	0	2	4	0	0	9	0	3534
0-24	3202	343	10	2	3	0	0	2	4	0	0	10	0	3576

Warrington ATC, Blackbrook Avenue

Produced by Road Data Services Ltd.

Channel 1 - Northbound

24/11/2015	Vehicle Classes													TOTAL
Hr Ending	1	2	3	4	5	6	7	8	9	10	11	12	13	
1	8	2	0	0	0	0	0	0	0	0	0	0	0	10
2	1	0	0	0	0	0	0	0	0	0	0	0	0	1
3	0	0	0	0	0	0	0	0	0	0	0	0	0	0
4	3	1	0	0	0	0	0	0	0	0	0	0	0	4
5	6	1	0	0	0	0	0	0	0	0	0	0	0	7
6	24	3	0	0	0	0	0	0	0	0	0	0	0	27
7	45	11	2	0	0	0	0	1	0	0	0	1	0	60
8	133	26	1	0	0	0	0	0	0	0	0	1	0	161
9	213	21	1	0	1	0	0	0	0	0	0	1	0	237
10	120	22	2	0	0	0	0	1	0	0	2	1	0	148
11	107	18	2	0	1	0	0	0	0	0	0	1	0	129
12	118	14	0	0	0	0	0	0	0	0	0	2	0	134
13	156	19	0	0	1	0	0	0	0	0	0	0	0	176
14	122	18	1	0	0	0	1	0	0	0	0	1	0	143
15	148	24	0	0	2	0	0	0	1	0	0	0	0	175
16	201	31	0	0	2	0	1	1	0	0	0	0	0	236
17	269	48	1	0	0	0	0	0	0	0	0	1	0	319
18	296	32	1	0	0	0	0	0	0	0	0	0	0	329
19	225	20	1	0	0	0	0	0	0	0	0	0	0	246
20	147	15	0	0	1	0	0	0	0	0	0	1	0	164
21	96	18	0	0	0	0	0	0	1	0	0	1	0	116
22	101	5	0	0	0	0	0	0	0	0	0	0	0	106
23	47	6	0	0	0	0	0	0	0	0	0	0	0	53
24	30	2	0	0	0	0	0	0	0	0	0	0	0	32
7-19	2108	293	10	0	7	0	2	2	1	0	2	8	0	2433
6-22	2497	342	12	0	8	0	2	3	2	0	2	11	0	2879
6-24	2574	350	12	0	8	0	2	3	2	0	2	11	0	2964
0-24	2616	357	12	0	8	0	2	3	2	0	2	11	0	3013

Channel 2 - Southbound

24/11/2015	Vehicle Classes													TOTAL
Hr Ending	1	2	3	4	5	6	7	8	9	10	11	12	13	
1	9	1	0	0	0	0	0	0	0	0	0	0	0	10
2	6	0	0	0	0	0	0	0	0	0	0	0	0	6
3	0	0	0	0	0	0	0	0	0	0	0	0	0	0
4	7	0	0	0	0	0	0	0	0	0	0	0	0	7
5	6	0	0	0	0	0	0	0	0	0	0	0	0	6
6	17	6	0	0	0	0	0	0	0	0	0	1	0	24
7	88	10	0	0	0	0	0	0	0	0	0	0	0	98
8	355	33	1	1	1	0	0	0	0	0	0	0	0	391
9	492	52	1	0	0	0	0	0	0	0	0	2	0	547
10	265	31	1	0	0	0	0	0	0	0	0	1	0	298
11	157	10	1	0	0	0	0	1	0	0	1	0	0	170
12	146	12	1	0	0	0	0	0	0	0	0	0	0	159
13	146	15	1	0	0	0	0	0	0	0	0	1	0	163
14	148	16	0	1	1	0	0	0	0	0	0	1	0	167
15	168	22	1	0	1	0	0	0	0	0	0	1	0	193
16	197	20	4	0	1	0	0	0	0	0	0	0	0	222
17	221	28	3	0	0	0	0	0	0	0	0	0	0	252
18	274	26	1	0	0	0	0	0	0	0	0	1	0	302
19	213	14	0	0	0	0	0	0	0	0	0	0	0	227
20	136	10	0	0	0	0	0	0	0	0	0	0	0	146
21	89	18	1	0	0	0	0	0	0	0	0	0	0	108
22	72	2	0	0	0	0	0	0	0	0	0	0	0	74
23	42	4	0	0	0	0	0	0	0	0	0	0	0	46
24	33	1	0	0	0	0	0	0	0	0	0	0	0	34
7-19	2782	279	15	2	4	0	0	1	0	0	1	7	0	3091
6-22	3167	319	16	2	4	0	0	1	0	0	1	7	0	3517
6-24	3242	324	16	2	4	0	0	1	0	0	1	7	0	3597
0-24	3287	331	16	2	4	0	0	1	0	0	1	8	0	3650

Warrington ATC, Blackbrook Avenue

Produced by Road Data Services Ltd.

Channel 1 - Northbound

25/11/2015	Vehicle Classes													TOTAL
Hr Ending	1	2	3	4	5	6	7	8	9	10	11	12	13	
1	6	3	0	0	0	0	0	0	0	0	0	0	0	9
2	0	0	0	0	0	0	0	0	0	0	0	0	0	0
3	2	0	0	0	0	0	0	0	0	0	0	0	0	2
4	1	0	0	0	0	0	0	0	0	0	0	0	0	1
5	6	0	0	0	0	0	0	0	0	0	0	0	0	6
6	22	4	0	0	0	0	0	0	0	0	0	0	0	26
7	48	11	0	0	0	0	0	0	0	0	0	0	0	59
8	144	20	0	0	0	0	0	0	0	0	0	2	0	166
9	217	33	2	0	0	0	0	0	0	1	0	1	0	254
10	116	22	1	0	1	0	0	0	0	0	0	0	0	140
11	122	17	0	0	1	0	0	0	0	0	0	1	0	141
12	145	12	0	0	0	0	0	0	0	0	0	1	0	158
13	153	17	0	0	0	0	0	0	0	0	0	1	0	171
14	116	22	1	0	1	0	0	0	0	0	0	2	0	142
15	151	33	0	0	0	0	0	0	0	0	0	2	0	186
16	229	30	1	0	0	0	0	0	0	0	0	0	0	260
17	268	54	1	0	2	0	0	0	0	0	0	1	0	326
18	309	34	0	0	0	0	0	0	0	0	0	2	0	345
19	200	23	0	0	0	0	0	0	0	0	0	0	0	223
20	153	15	1	0	0	0	0	0	0	0	0	0	0	169
21	91	9	0	0	0	0	0	0	0	0	0	0	0	100
22	85	12	0	0	0	0	0	0	0	0	0	0	0	97
23	69	3	0	0	0	0	0	0	0	0	0	0	0	72
24	20	0	0	0	0	0	0	0	0	0	0	0	0	20
7-19	2170	317	6	0	5	0	0	0	0	1	0	13	0	2512
6-22	2547	364	7	0	5	0	0	0	0	1	0	13	0	2937
6-24	2636	367	7	0	5	0	0	0	0	1	0	13	0	3029
0-24	2673	374	7	0	5	0	0	0	0	1	0	13	0	3073

Channel 2 - Southbound

25/11/2015	Vehicle Classes													TOTAL
Hr Ending	1	2	3	4	5	6	7	8	9	10	11	12	13	
1	8	3	0	0	0	0	0	0	0	0	0	0	0	11
2	1	1	0	0	0	0	0	0	0	0	0	0	0	2
3	0	0	0	0	0	0	0	0	0	0	0	0	0	0
4	2	0	0	0	0	0	0	0	0	0	0	0	0	2
5	5	0	0	0	0	0	0	0	0	0	0	0	0	5
6	24	4	0	0	0	0	0	0	0	0	0	0	0	28
7	97	13	0	0	0	0	1	0	0	0	0	0	0	111
8	375	45	1	0	0	0	0	0	0	0	0	1	0	422
9	458	51	4	0	1	0	0	0	0	0	0	1	0	515
10	224	23	0	0	0	0	0	0	0	0	0	4	0	251
11	149	22	0	0	1	0	0	0	0	0	0	0	0	172
12	131	10	2	0	0	0	0	0	0	0	0	1	0	144
13	154	16	0	0	1	0	0	0	0	0	0	1	0	172
14	182	18	1	0	0	0	0	0	0	0	0	0	0	201
15	176	23	0	0	0	0	0	0	0	0	0	0	0	199
16	204	26	1	0	0	0	0	0	0	0	0	0	0	231
17	218	41	3	1	0	0	0	0	0	0	0	2	0	265
18	248	28	0	0	0	0	0	0	0	0	0	0	0	276
19	219	22	0	0	0	0	0	0	0	0	0	0	0	241
20	164	15	0	1	0	0	0	0	0	0	0	0	0	180
21	90	6	0	0	0	0	0	0	0	0	0	0	0	96
22	64	4	0	0	0	0	0	0	0	0	0	0	0	68
23	52	1	0	0	0	0	0	0	0	0	0	0	0	53
24	20	2	0	0	0	0	0	0	0	0	0	0	0	22
7-19	2738	325	12	1	3	0	0	0	0	0	0	10	0	3089
6-22	3153	363	12	2	3	0	1	0	0	0	0	10	0	3544
6-24	3225	366	12	2	3	0	1	0	0	0	0	10	0	3619
0-24	3265	374	12	2	3	0	1	0	0	0	0	10	0	3667

Warrington ATC, Blackbrook Avenue

Produced by Road Data Services Ltd.

Channel 1 - Northbound

26/11/2015	Vehicle Classes													TOTAL
Hr Ending	1	2	3	4	5	6	7	8	9	10	11	12	13	
1	5	2	0	0	0	0	0	0	0	0	0	0	0	7
2	0	0	0	0	0	0	0	0	0	0	0	0	0	0
3	2	1	0	0	0	0	0	0	0	0	0	0	0	3
4	1	0	0	0	0	0	0	0	0	0	0	0	0	1
5	6	0	0	0	0	0	0	0	0	0	0	0	0	6
6	20	3	0	0	0	0	0	0	0	0	0	0	0	23
7	48	7	0	0	0	0	0	0	0	0	0	0	0	55
8	128	26	1	0	0	0	0	0	0	0	0	0	0	155
9	228	18	1	0	1	0	0	0	0	0	0	1	0	249
10	112	18	2	0	0	0	0	1	0	0	3	1	0	137
11	118	13	0	0	1	0	0	0	0	0	0	0	0	132
12	137	18	0	0	1	0	0	1	0	0	0	1	0	158
13	155	12	1	0	0	0	0	0	0	0	0	0	0	168
14	139	20	1	1	0	0	0	0	0	0	0	0	0	161
15	165	27	1	0	0	0	0	0	0	0	0	0	0	193
16	211	30	1	0	1	0	0	0	0	0	0	0	0	243
17	315	44	0	0	1	0	0	0	0	0	0	0	0	360
18	298	29	0	0	0	0	1	0	0	0	0	1	0	329
19	234	23	0	0	2	0	0	0	0	0	0	0	0	259
20	160	8	1	0	0	0	0	0	0	0	0	0	0	169
21	128	7	0	0	0	0	0	0	0	0	0	1	0	136
22	95	6	1	0	0	0	0	0	0	0	0	0	0	102
23	60	3	0	0	0	0	0	0	0	0	0	0	0	63
24	29	2	0	0	0	0	0	0	0	0	0	0	0	31
7-19	2240	278	8	1	7	0	1	2	0	0	3	4	0	2544
6-22	2671	306	10	1	7	0	1	2	0	0	3	5	0	3006
6-24	2760	311	10	1	7	0	1	2	0	0	3	5	0	3100
0-24	2794	317	10	1	7	0	1	2	0	0	3	5	0	3140

Channel 2 - Southbound

26/11/2015	Vehicle Classes													TOTAL
Hr Ending	1	2	3	4	5	6	7	8	9	10	11	12	13	
1	5	2	0	0	0	0	0	0	0	0	0	0	0	7
2	1	0	0	0	0	0	0	0	0	0	0	0	0	1
3	2	0	0	0	0	0	0	0	0	0	0	0	0	2
4	1	0	0	0	0	0	0	0	0	0	0	0	0	1
5	5	0	0	0	0	0	0	0	0	0	0	0	0	5
6	23	4	0	0	0	0	0	0	0	0	0	0	0	27
7	94	6	0	0	0	0	0	0	0	0	0	0	0	100
8	353	47	2	0	1	0	0	0	0	0	0	0	0	403
9	465	46	1	0	1	0	0	0	1	0	0	2	0	516
10	257	37	1	0	0	0	0	0	0	0	0	1	0	296
11	138	19	0	0	0	0	0	0	0	0	0	1	0	158
12	161	15	1	0	0	0	0	0	0	0	0	0	0	177
13	152	9	0	0	0	0	0	0	0	0	0	2	0	163
14	168	13	1	0	1	0	0	0	0	0	0	0	0	183
15	203	18	0	0	0	0	0	0	0	0	0	0	0	221
16	208	20	0	0	1	0	0	0	0	0	0	0	0	229
17	243	30	2	0	1	0	0	0	0	0	0	0	0	276
18	296	22	0	0	0	0	0	0	0	0	0	0	0	318
19	209	18	0	0	0	0	0	0	0	0	0	1	0	228
20	169	7	1	0	0	0	0	0	0	0	0	0	0	177
21	111	7	1	0	0	0	0	0	0	0	0	0	0	119
22	78	3	0	0	0	0	0	0	0	0	0	0	0	81
23	40	0	0	0	0	0	0	0	0	0	0	0	0	40
24	50	2	0	0	0	0	0	0	0	0	0	0	0	52
7-19	2853	294	8	0	5	0	0	0	1	0	0	7	0	3168
6-22	3305	317	10	0	5	0	0	0	1	0	0	7	0	3645
6-24	3395	319	10	0	5	0	0	0	1	0	0	7	0	3737
0-24	3432	325	10	0	5	0	0	0	1	0	0	7	0	3780

Blackbrook Avenue
Northbound

7 Day Average Northbound

Time	Total
0000	16
0100	5
0200	3
0300	4
0400	8
0500	21
0600	43
0700	123
0800	189
0900	133
1000	136
1100	164
1200	184
1300	176
1400	187
1500	247
1600	293
1700	290
1800	221
1900	151
2000	102
2100	80
2200	57
2300	32
07-19	2345
06-00	2810
00-00	2867

AAWT Factor 9.8823

5 Day Average Northbound

Time	Total
0000	9
0100	2
0200	2
0300	2
0400	7
0500	27
0600	54
0700	160
0800	245
0900	147
1000	131
1100	153
1200	175
1300	159
1400	189
1500	263
1600	331
1700	335
1800	254
1900	168
2000	111
2100	90
2200	60
2300	30
07-19	2540
06-00	3054
00-00	3102

AAWT Factor 10.5267

Blackbrook Avenue
Southbound

7 Day Average Southbound

Time	Total
0000	16
0100	7
0200	3
0300	4
0400	7
0500	22
0600	78
0700	301
0800	382
0900	235
1000	174
1100	172
1200	179
1300	200
1400	211
1500	216
1600	250
1700	256
1800	192
1900	146
2000	97
2100	70
2200	44
2300	34
07-19	2767
06-00	3236
00-00	3294

AAWT Factor 8.2976

5 Day Average Southbound

Time	Total
0000	9
0100	3
0200	2
0300	3
0400	6
0500	26
0600	99
0700	404
0800	496
0900	274
1000	173
1100	162
1200	169
1300	195
1400	211
1500	232
1600	269
1700	298
1800	222
1900	161
2000	103
2100	74
2200	45
2300	34
07-19	3106
06-00	3622
00-00	3671

AAWT Factor 9.1229

Appendix 5

ATC Data – Delph Lane

Warrington ATC A, Delph Road

Produced by Road Data Services Ltd.

Channel 1 - Northbound

Vehicle Flow

Week 1

Hr Ending	30/03/2019 Saturday	31/03/2019 Sunday	01/04/2019 Monday	02/04/2019 Tuesday	03/04/2019 Wednesday	04/04/2019 Thursday	05/04/2019 Friday	5 Day Ave	7 Day Ave
1	25	17	6	5	4	4	6	5	10
2	8	6	6	4	2	4	2	4	5
3	7	0	0	0	3	1	3	1	2
4	6	7	2	4	10	3	4	5	5
5	8	5	14	10	9	8	13	11	10
6	25	18	44	59	61	50	49	53	44
7	30	23	112	123	120	116	112	117	91
8	72	35	255	274	301	308	260	280	215
9	106	62	332	406	368	351	297	351	275
10	176	131	152	177	171	179	178	171	166
11	244	155	140	136	144	155	147	144	160
12	243	193	156	145	167	157	193	164	179
13	223	216	193	183	146	142	185	170	184
14	236	248	170	187	176	198	207	188	203
15	227	238	233	257	204	203	305	240	238
16	191	185	215	272	294	277	362	284	257
17	180	194	394	467	435	472	478	449	374
18	192	128	449	465	455	582	447	480	388
19	145	125	209	230	250	293	247	246	214
20	100	99	147	128	150	142	145	142	130
21	67	78	96	101	116	116	76	101	93
22	61	48	77	62	74	68	67	70	65
23	44	36	48	58	49	56	52	53	49
24	34	13	8	8	15	18	23	14	17
7-19	2235	1910	2898	3199	3111	3317	3306	3166	2854
6-22	2493	2158	3330	3613	3571	3759	3706	3596	3233
6-24	2571	2207	3386	3679	3635	3833	3781	3663	3299
0-24	2650	2260	3458	3761	3724	3903	3858	3741	3373

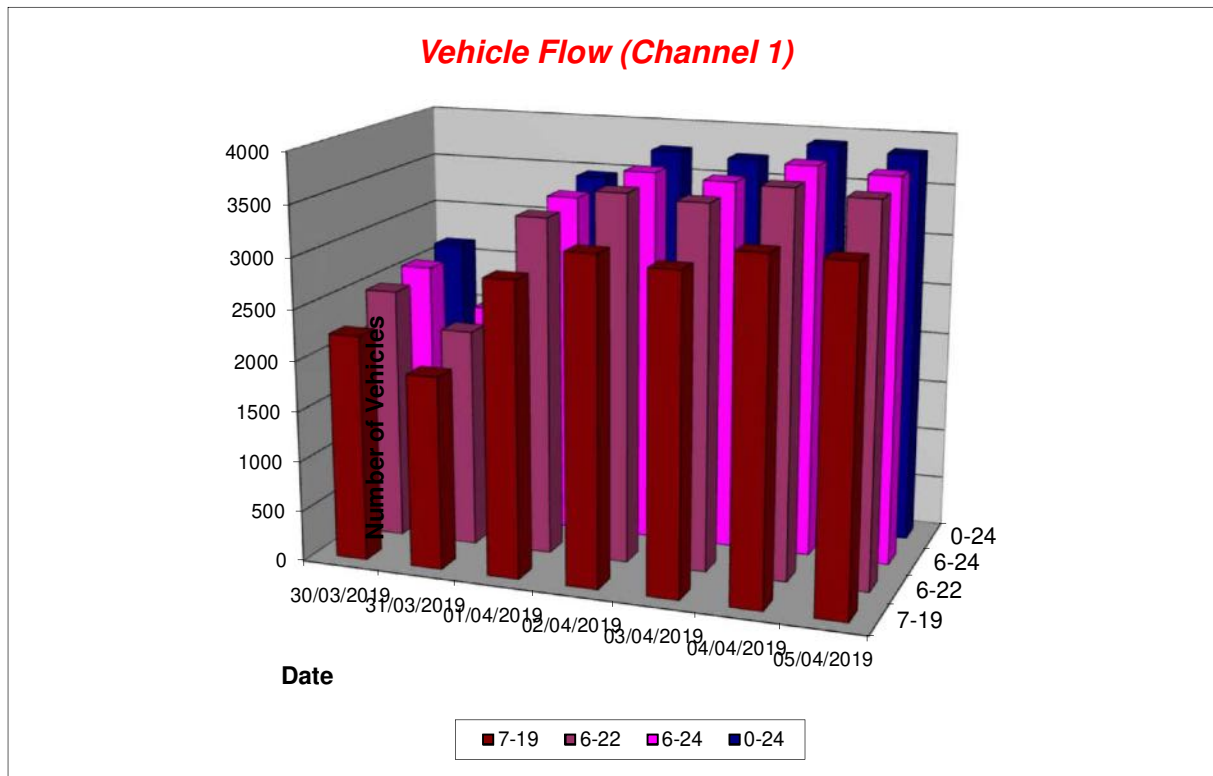

Warrington ATC A, Delph Road

Produced by Road Data Services Ltd.

Channel 2 - Southbound

Vehicle Flow

Week 1

Hr Ending	30/03/2019 Saturday	31/03/2019 Sunday	01/04/2019 Monday	02/04/2019 Tuesday	03/04/2019 Wednesday	04/04/2019 Thursday	05/04/2019 Friday	5 Day Ave	7 Day Ave
1	30	26	6	8	7	6	9	7	13
2	13	12	5	4	3	5	8	5	7
3	6	0	3	6	4	8	1	4	4
4	10	10	4	3	2	0	2	2	4
5	11	12	8	10	20	10	13	12	12
6	21	17	63	65	51	58	47	57	46
7	33	13	172	200	196	184	183	187	140
8	66	28	432	404	455	438	398	425	317
9	98	52	477	574	554	490	404	500	378
10	167	92	262	346	375	240	243	293	246
11	216	153	149	174	193	156	171	169	173
12	259	204	154	164	166	159	297	188	200
13	263	252	174	183	169	165	216	181	203
14	254	263	142	190	189	182	241	189	209
15	237	246	207	187	196	198	250	208	217
16	214	233	258	243	273	231	305	262	251
17	235	210	378	338	309	348	322	339	306
18	232	169	346	368	401	362	312	358	313
19	155	140	221	221	234	228	222	225	203
20	110	141	129	149	183	152	130	149	142
21	64	111	100	99	126	84	87	99	96
22	48	61	73	71	81	66	77	74	68
23	51	48	45	76	54	43	70	58	55
24	54	18	20	22	18	41	42	29	31
7-19	2396	2042	3200	3392	3514	3197	3381	3337	3017
6-22	2651	2368	3674	3911	4100	3683	3858	3845	3464
6-24	2756	2434	3739	4009	4172	3767	3970	3931	3550
0-24	2847	2511	3828	4105	4259	3854	4050	4019	3636

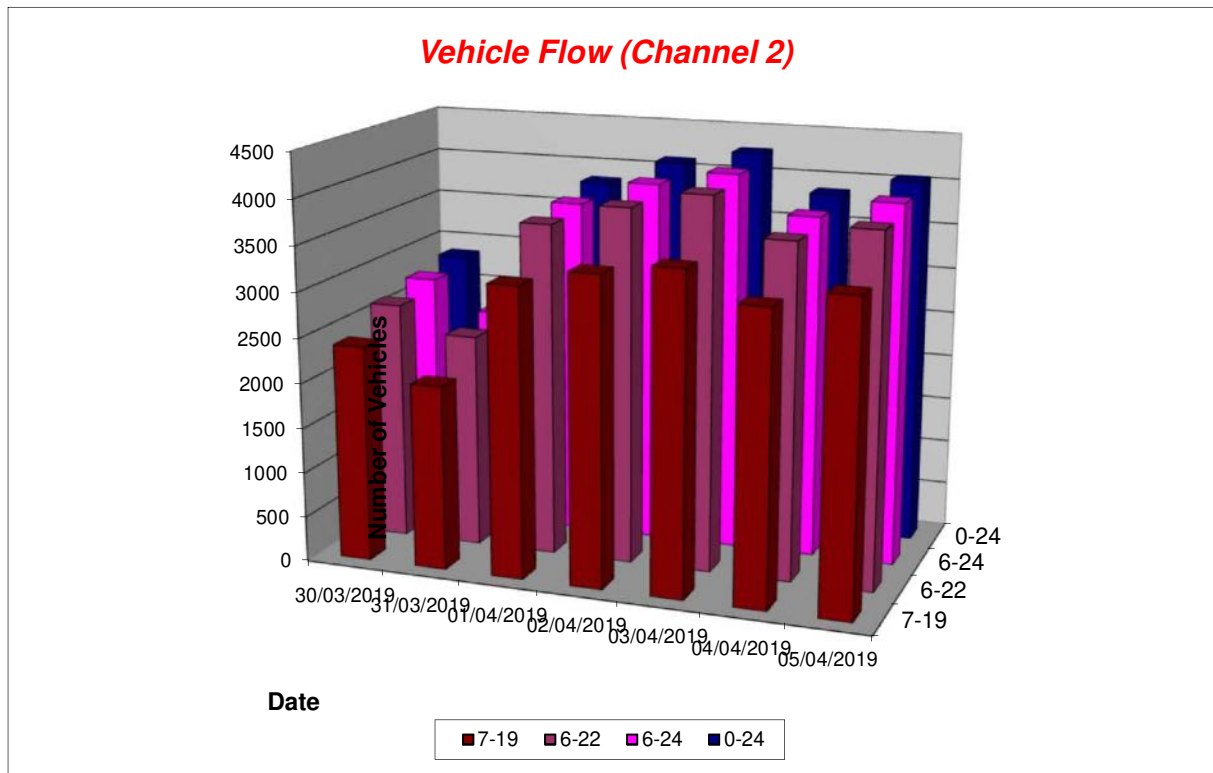

Delph Lane
Northbound

7 Day Average Northbound

Time	Total
0000	10
0100	5
0200	2
0300	5
0400	10
0500	44
0600	91
0700	215
0800	275
0900	166
1000	160
1100	179
1200	184
1300	203
1400	238
1500	257
1600	374
1700	388
1800	214
1900	130
2000	93
2100	65
2200	49
2300	17
07-19	2854
06-00	3299
00-00	3373

AAWT Factor 8.1248

5 Day Average Northbound

Time	Total
0000	5
0100	4
0200	1
0300	5
0400	11
0500	53
0600	117
0700	280
0800	351
0900	171
1000	144
1100	164
1200	170
1300	188
1400	240
1500	284
1600	449
1700	480
1800	246
1900	142
2000	101
2100	70
2200	53
2300	14
07-19	3166
06-00	3663
00-00	3741

AAWT Factor 8.8218

Delph Lane
Southbound

7 Day Average Southbound

Time	Total
0000	13
0100	7
0200	4
0300	4
0400	12
0500	46
0600	140
0700	317
0800	378
0900	246
1000	173
1100	200
1200	203
1300	209
1400	217
1500	251
1600	306
1700	313
1800	203
1900	142
2000	96
2100	68
2200	55
2300	31
07-19	3017
06-00	3550
00-00	3636

AAWT Factor 8.4801

5 Day Average Southbound

Time	Total
0000	7
0100	5
0200	4
0300	2
0400	12
0500	57
0600	187
0700	425
0800	500
0900	293
1000	169
1100	188
1200	181
1300	189
1400	208
1500	262
1600	339
1700	358
1800	225
1900	149
2000	99
2100	74
2200	58
2300	29
07-19	3337
06-00	3931
00-00	4019

AAWT Factor 9.1684

Appendix 2

Transport Advice Note TA 79/99 (May 1999)

**VOLUME 5 ASSESSMENT AND
PREPARATION OF ROAD
SCHEMES**

**SECTION 1 PREPARATION AND
IMPLEMENTATION**

PART 3

TA 79/99 AMENDMENT NO 1

TRAFFIC CAPACITY OF URBAN ROADS

SUMMARY

Advice Note TA 79/99, published February 1999, was wrongly placed in Section 2 of DMRB Volume 5. All users should arrange for the document TA 79/99 to be inserted in Volume 5, Section 1, Part 3 of DMRB. References within the document to Section 2, Part 2 should also be corrected accordingly.

INSTRUCTIONS FOR USE

1. Remove Advice Note TA 79/99 from Volume 3 of the DMRB.
2. Amend the volume references on all pages of TA 79/99 to read Volume 5, Section 1, Part 3 of DMRB.
3. Remove existing title page and insert amended title page and Note to Users in front of Contents sheet of TA 79/99.
4. Enter the details of the amendment on the Registration of Amendment sheet, sign and date to confirm that the amendment has been incorporated.

Note: A quarterly index with a full set of Volume Contents Pages is available separately from The Stationery Office Ltd.



THE HIGHWAYS AGENCY



THE SCOTTISH OFFICE DEVELOPMENT DEPARTMENT



**THE WELSH OFFICE
Y SWYDDFA GYMREIG**



**THE DEPARTMENT OF THE ENVIRONMENT FOR
NORTHERN IRELAND**

Traffic Capacity of Urban Roads

Summary: Advice Note TA 79/99, published February 1999, was wrongly placed in Section 2 of DMRB Volume 5.

Note to Users

1. Advice Note TA 79/99 published by the Highways Agency in February 1999 was placed erroneously in DMRB 5.2.2.
2. All users should arrange for the document TA 79/99 to be inserted in Volume 5, Section 1, Part 3 of DMRB. References within the document to Section 2, Part 2 should also be corrected accordingly.

REGISTRATION OF AMENDMENTS

Amend No	Page No	Signature & Date of incorporation of amendments	Amend No	Page No	Signature & Date of incorporation of amendments

REGISTRATION OF AMENDMENTS

Amend No	Page No	Signature & Date of incorporation of amendments	Amend No	Page No	Signature & Date of incorporation of amendments

**VOLUME 5 ASSESSMENT AND
PREPARATION OF ROAD
SCHEMES**

**SECTION 2 PREPARATION AND
IMPLEMENTATION**

PART 2

TA 79/99

TRAFFIC CAPACITY OF URBAN ROADS

Contents

Chapter

1. Introduction
2. General Principles
3. Determination of Urban Road Capacity
4. Assessment Procedure
5. Enquiries

1. INTRODUCTION

General

1.1 Traffic flows on urban trunk roads in Greater and Outer London has been analysed to assess the capacities that can be achieved for different road types and widths. From this information the main features that affect capacity have been defined and the results presented in tabular form.

1.2 This document supersedes section 5 and Appendix 2 of TD 20/85 "Traffic Flows and Carriageway Width Assessment". TD 20/85 is now entirely superseded by both this document and TA 46/97. TD 20/85 is hereby withdrawn.

1.3 For **rural** roads reference should be made to TA 46/97 "Traffic Flow Ranges for Use in the Assessment of New Rural Roads".

Scope

1.4 This Advice Note gives the maximum hourly vehicle capacity for various types of Urban Trunk Road. All capacities quoted are for traffic compositions including up to 15% heavy vehicles; corrections are provided for higher proportions.

1.5 The capacities may be used as starting points in the design and assessment of new urban trunk road links. They may also be used as a guide to the capacity of existing urban roads, and for assessing the likely effect on capacity of proposed changes to specific road features including carriageway width.

1.6 It should be borne in mind that the assessment of carriageway width is not based solely on peak hour travel demand. Cost and environmental impact should also be taken into account. A judgement may therefore have to be made between adopting reduced width of carriageway, weighed against any adverse effects incurred by providing for a higher level of demand.

Implementation

1.7 This Advice Note should be used forthwith for all schemes for the construction of urban trunk roads including improvements, with the approval of the Overseeing Organisation. The exceptions are schemes currently being prepared where this would result in significant additional expense or delay progress.

Definitions

1.8 Urban Motorway
A motorway with a speed limit of 60 mph or less within a built up area.

1.9 Urban All-Purpose Road (UAP)
An all-purpose road within a built up area, either a single carriageway with a speed limit of 40 mph or less or a dual carriageway with a speed limit of 60 mph or less.

1.10 Capacity
For the purposes of this Advice Note, capacity is defined as the maximum sustainable flow of traffic passing in 1 hour, under favourable road and traffic conditions.

2. GENERAL PRINCIPLES

Application of Capacity values

2.1 The guidance in this document should be used flexibly. In some circumstances, the use of a reduced width of carriageway will result in significant savings or environmental benefits, which outweigh the disbenefits of congestion during peak periods.

2.2 The capacity of urban roads can be affected by a wide range of factors that may not always be accurately predicted by the road features identified. For this reason capacity flows may be up to 10% more or less than the values given in this document.

Features Affecting Capacity

2.3 The potential capacity of a link will not be reached if either the capacity of junctions along the link or the capacity of the adjoining network is lower than the link in question. The flow on an urban road may also be affected by turning movements restricting the mainline capacity. Such constraints should be identified at an early stage.

2.4 Urban roads normally have higher flows in the morning and evening peaks than at other times of day. Improving features that affect the capacity would help prevent congestion during these periods.

2.5 The flows given in the tables are the maximum that typical urban roads can carry consistently in an hour. The principal factors that may affect flow levels on urban roads are given in Table 1.
For motorways the prime determinant is the carriageway width, but for all-purpose roads flow is also affected by the speed limit, the frequency of side roads, the degree of parking and loading, the frequency of at grade pedestrian crossings, bus stops, and accesses.

2.6 The capacity of the lower width roads will be significantly reduced by parking and temporary width restrictions caused by such activities as maintenance and Statutory Undertakers' Works. The lowest widths are unlikely to be suitable for bus routes or for significant volumes of heavy goods vehicles.

2.7 Roads in Category UAP3 and UAP4 may carry high proportions of local traffic, resulting in an increase in turning movements at junctions and accesses.

2.8 Capacity will also be affected by prevailing weather and night conditions. The capacities shown are for "favourable" daylight conditions.

Feature	ROAD TYPE				
	Urban Motorway	Urban All-purpose			
	UM	UAP1	UAP2	UAP3	UAP4
General Description	Through route with grade separated junctions, hardshoulders or hardstrips, and motorway restrictions.	High standard single/dual carriageway road carrying predominantly through traffic with limited access.	Good standard single/dual carriageway road with frontage access and more than two side roads per km.	Variable standard road carrying mixed traffic with frontage access, side roads, bus stops and at-grade pedestrian crossings.	Busy high street carrying predominantly local traffic with frontage activity including loading and unloading.
Speed Limit	60mph or less	40 to 60 mph for dual, & generally 40mph for single carriageway	Generally 40 mph	30 mph to 40 mph	30mph
Side Roads	None	0 to 2 per km	more than 2 per km	more than 2 per km	more than 2 per km
Access to roadside development	None. Grade separated for major only.	limited access	access to residential properties	frontage access	unlimited access to houses, shops & businesses
Parking and loading	none	restricted	restricted	unrestricted	unrestricted
Pedestrian crossings	grade separated	mostly grade separated	some at-grade	some at-grade	frequent at-grade
Bus stops	none	in lay-bys	at kerbside	at kerbside	at kerbside

Table 1 Types of Urban roads and the features that distinguish them

3. DETERMINATION OF URBAN ROAD CAPACITY

3.1 Table 1 sets out the types of Urban Roads and the features that distinguish between them and affect their traffic capacity. Tables 2 & 3 give the flow capacity for each road type described in Table 1.

3.2 Table 4 gives the adjustments when the proportion of heavy vehicles in a one way flow exceeds 15%. A heavy vehicle is defined in this context as OGV1, OGV2 or Buses and Coaches as given in the COBA Manual (DMRB 13.1 Part 4, Chapter 8).

3.3 The flows for road type UM in Table 2 apply to urban motorways where junctions are closely spaced giving weaving lengths of less than 1 kilometre. Urban motorways with layout and junction spacing similar to rural motorways can carry higher flows and TA46/97 "Traffic Flow Ranges for Use in the Assessment of New Rural Roads" will be more applicable.

3.4 Flows for single carriageways are based upon a 60/40 directional split in the flow. The one-way flows shown in Table 2 represent the busiest flow 60% figure.

3.5 The capacities shown apply to gradients of up to 5-6%. Special consideration should be made for steeper gradients, which would reduce capacity.

3.6 On-road parking reduces the effective road width and disrupts flow, e.g. where parking restrictions are not applied on road type UAP2 the flows are likely to be similar to UAP3 where unrestricted parking applies, see Table 1, Similarly effective parking restrictions can lead to higher flows.

		Two-way Single Carriageway- Busiest direction flow (Assumes a 60/40 directional split)								Dual Carriageway				
		Total number of Lanes								Number of Lanes in each direction				
		2				2-3	3	3-4	4	4+	2		3	4
Carriageway width		6.1m	6.75m	7.3m	9.0m	10.0m	12.3m	13.5m	14.6m	18.0m	6.75m	7.3m	11.0m	14.6m
Road type	UM	Not applicable									4000	5600	7200	
	UAP1	1020	1320	1590	1860	2010	2550	2800	3050	3300	3350	3600	5200	*
	UAP2	1020	1260	1470	1550	1650	1700	1900	2100	2700	2950	3200	4800	*
	UAP3	900	1110	1300	1530	1620	*	*	*	*	2300	2600	3300	*
	UAP4	750	900	1140	1320	1410	*	*	*	*	*	*	*	*

Table 2 Capacities of Urban Roads
One-way hourly flows in each direction

Notes

- Capacities are in vehicles per hour.
- HGV ≤ 15%
- (*) Capacities are excluded where the road width is not appropriate for the road type and where there are too few examples to give reliable figures.

Carriageway width		6.1m	6.75m	7.3m	9.0m	10.0m	11.0m
		2 lanes			2-3 lanes		3 lanes
Road type	UAP1		2950	3250	3950	4450	4800
	UAP2	1800	2000	2200	2850	3250	3550

Table 3 Capacities of Urban One-Way roads, hourly flows

Notes

1. Capacities are in vehicles per hour.
2. Capacities for one way road types UAP1 at 6.1m width, UAP3 and UAP4 are not shown as there are too few examples to give reliable capacities.
3. Capacities for one-way roads (e.g. UAP2 at 7.3m and 11.0m carriageway widths) are generally less than capacities of dual carriageways in one direction shown in Table 2. The reason is that one-way roads are often of short lengths and form part of a gyratory system between junctions, necessitating high proportion of vehicle weaving and stopping, thereby decreasing the capacities.

Heavy Vehicle Content	Total reduction in flow level (vehs/hr)		
	UM and UAP dual carriageway road	Single carriageway UAP road having width of 10m or wider	Single carriageway UAP road having width less than 10m
	per lane	per carriageway	per carriageway
15 - 20%	100	100	150
20 - 25%	150	150	225

Table 4 Reduction in flow due to Heavy Vehicle Content

4. ASSESSMENT PROCEDURE

4.1 The capacities given in Tables 2 - 4 provide a guide for the assessment of an appropriate carriageway width and standard. They may be applied to both the design of new urban roads and to the improvement of existing roads. The capacities are intended to help designers make a judgement as to which carriageway standard is likely to provide an acceptable level of service within an urban context when operating close to capacity. The capacities apply to links and take no account of the effects of junctions.

4.2 For improvement options to existing roads the designer should make an appraisal of each of the road features and thereby determine the most appropriate road type given in Table 1. An assessment may then be made of the expected capacity using Tables 2 – 4. It should be calibrated with observed traffic flows to validate the appraisal, taking account of any network constraints that may limit a desirable flow. The effect of link capacity on changes to specific features should then be examined.

4.3 Observations of existing traffic flows should be undertaken by manual classified counts and account taken of hourly, daily and seasonal variations. Reference to continuous automatic traffic count data if available would assist in identifying periods of maximum flow levels and whether traffic levels are operating close to capacity.

4.4 For the design of new urban roads, the carriageway standard options presented herein provide a guide to the desirable standard of carriageway provision given the features of the road and expected traffic levels. They should not be used alone as a design tool, because factors other than peak hour flows should also be considered. They should be regarded as a starting point for more detailed analysis of traffic, economic and environmental aspects.

4.5 For the estimation of future traffic demand levels for urban roads where changes to travel patterns over a wide area are likely to occur, reference should be made to “Traffic Appraisal in Urban Areas” (DMRB Volume 12 Section 2 Part 1).

5. ENQUIRIES

All technical enquiries or comments on this document should be sent in writing as appropriate to:

Traffic, Safety and Environment Divisional Director
Highways Agency
St Christopher House
Southwark Street
London
SE1 0TE

G CLARKE
Traffic Safety and Environmental
Divisional Director

The Deputy Chief Engineer
The Scottish Office Development Department
National Roads Directorate
Victoria Quay
Edinburgh EH6 6QQ

J HOWISON
Deputy Chief Engineer

Head of Roads Major Projects Division
Welsh Office
Highways Directorate
Cathays Park
Cardiff
CF1 3NQ

B H HAWKER
Head of Roads
Major Projects Division

Assistant Technical Director
Department of the Environment for
Northern Ireland
Roads Service
Clarence Court
10-18 Adelaide Street
Belfast BT2 8GB

D O'HAGAN
Assistant Technical Director

TECHNICAL NOTE

PROJECT: Peel Hall, Warrington

REPORT: 1901/TN/10 – Parking and Measures to the South

DATE: January 2020

1. Part of the mitigation proposals to the south of the Peel Hall site is to provide car parking within the highway verge. The reason for this is that when the road hierarchy for the area was designed at the time of construction, the demand for on-street parking was significantly less than at present and as a result this can reduce the free flow of traffic.
2. This Technical Note has been provided to confirm the current parking demand on the area to the south of the Peel Hall site i.e. Sandy Lane West, Poplars Avenue, and Capesthorpe Road (between Poplars Avenue and Blackbrook Avenue) and to investigate the amount of verge parking that could be created.
3. The study has been carried out using a combination of parking surveys and on-site observations.
4. At the inquiry (APP/M/0655/W/17/3178530), the development impact on the area to the south of Peel Hall was highlighted as an area of concern in terms of vehicle capacity, the additional traffic movement, safety and character of the area. To address these concerns, two measures were put forward:
 - i. An increase in the amount of verge parking on Sandy Lane West, Poplars Avenue and Capesthorpe Road
 - ii. An extension to the existing 20mph speed limit on Poplars Avenue
5. Since the inquiry, the Council have also expressed an interest in alterations to the existing traffic calming on Capesthorpe Road and further traffic calming measures in this area to the south, which can be defined as those residential areas around the following links:
 - i. Capesthorpe Road
 - ii. Poplars Avenue
 - iii. Statham Avenue
 - iv. Howson Road
 - v. Sandy Lane
 - vi. Cleveland Road
 - vii. Greenwood Crescent
 - viii. Cotswold Road

6. This Technical Note therefore also summarises what additional traffic calming measures could be implemented to complement the proposed verge parking and extensions to the 20mph speed limit to further address the Inspector’s comments and mitigate for impact on character and pedestrian/cyclist movements that may arise as a result of development traffic on this area to the south in terms.

Parking Surveys

7. A parking survey was carried out in the area to the south of the Peel Hall site on Thursday 31st October at 11pm and Saturday 2nd November 2019 at 1pm. The parking survey data is contained in full in **Appendix 1**.
8. The parking survey was carried out in eight zones within the study area. The zones were as follows:
 - i. Sandy Lane West (NE-bound)
 - ii. Sandy Lane West (SW-bound)
 - iii. Poplars Avenue, north of Capesthorpe Road (NW-bound)
 - iv. Poplars Avenue, north of Capesthorpe Road (SE-bound)
 - v. Poplars Avenue, south of Capesthorpe Road (N-bound)
 - vi. Poplars Avenue, south of Capesthorpe Road (S-bound)
 - vii. Capesthorpe Road, east of Poplars Avenue (NE-bound)
 - viii. Capesthorpe Road, east of Poplars Avenue (SW-bound)
9. **Figure 1** shows the parking survey zones on a street map for reference.

Figure 1 - Parking Survey Zones

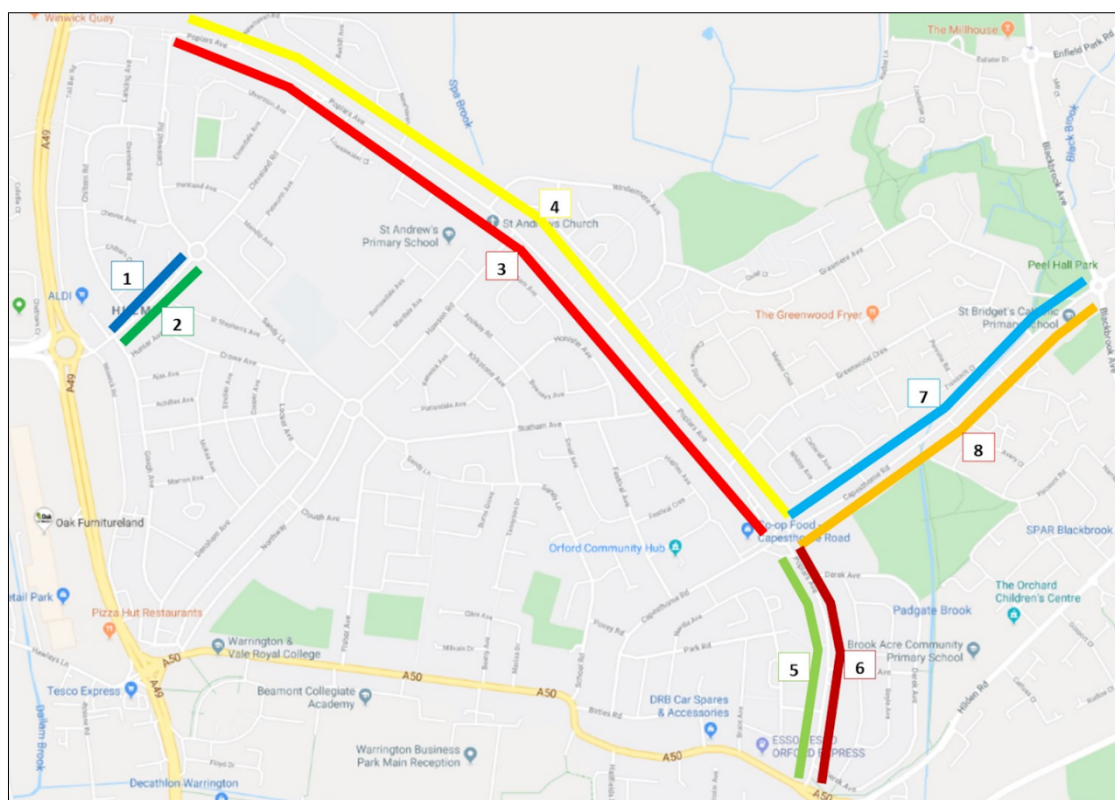

10. The parking survey recorded how many available vehicles were parked on-street in each zone (**Table 1**), as well as how many vehicles were parked informally e.g. on grass verges, on footways or in front of driveways (**Table 2**).

Table 1 – Number of vehicles parked in each zone

Location	Thursday 31st October 2019; 23:00	Saturday 2nd November 2019, 13:00
	Occupied	
Zone 1	0	0
Zone 2	0	0
Zone 3	35	13
Zone 4	37	28
Zone 5	22	19
Zone 6	5	6
Zone 7	12	14
Zone 8	7	1
Total	118	81

Table 2 – Number of vehicles parked informally in each zone

Location	Thursday 31st October 2019; 23:00	Saturday 2nd November 2019, 13:00
	Vehicles Parked on Grass Verges, Pavements and in front of Driveways with all 4 wheels off the road	
Zone 1	7	5
Zone 2	4	1
Zone 3	39	37
Zone 4	33	26
Zone 5	6	5
Zone 6	8	3
Zone 7	5	4
Zone 8	10	7
Total	112	88

11. Additionally, the parking survey recorded how many vehicles were parked illegally in each zone within the study area. The results of this are shown in **Table 3**.

Table 3 – Number of vehicles parked illegally

Location	Total Spaces	Thursday 31st October 2019; 23:00	Saturday 2nd November 2019, 13:00
		Illegal Parking	
Zone 1		0	0
Zone 2		0	0
Zone 3		2	0
Zone 4		0	0
Zone 5		0	0
Zone 6		0	0
Zone 7		0	0
Zone 8		0	0
Total		2	0

12. In order to calculate parking demand in each zone, the results contained within **Tables 1, 2 and 3** have been added together and this is shown in **Table 4**.

Table 4 – Parking demand in the study area

Location	Thursday 31st October 2019; 23:00				Saturday 2nd November 2019, 13:00			
	Spaces Occupied	Parked Informally	Illegally Parked	Total Parking Demand	Spaces Occupied	Parked Informally	Illegally Parked	Total Parking Demand
Zone 1	0	7	0	7	0	5	0	5
Zone 2	0	4	0	4	0	1	0	1
Zone 3	35	39	2	76	13	37	0	50
Zone 4	37	33	0	70	28	26	0	54
Zone 5	22	6	0	28	19	5	0	24
Zone 6	5	8	0	13	6	3	0	9
Zone 7	12	5	0	17	14	4	0	18
Zone 8	7	10	0	17	1	7	0	8
Total	118	112	2	232	81	88	0	169

Verge Parking Capacity

13. In order to assess the feasibility of providing parking in the highway verges, on site observations and measurements were taken. The initial plan contained at **Appendix 2** indicates the approximate areas of highway verge available for parking based on an OS plan of the study area.
14. **Table 5** sets out the estimated parking capacity that could be created in the grass verges of Poplars Avenue and Capesthorpe Road (between Poplars Avenue and Blackbrook Avenue) or within the wide footway at Sandy Lane West, as highlighted on the plan at **Appendix 2**. It should also be noted that trees are located within the verges and the retention of these were taken account of in the calculations but are not shown on the OS plan.

Table 5 – Potential Verge Parking

Location	Potential Creation of Verge/Footway Parking Spaces
Zone 1	12
Zone 2	8
Zone 3	59
Zone 4	42
Zone 5	23
Zone 6	17
Zone 7	14
Zone 8	25
Total	200

15. From **Table 5** it can be seen that up to around 200 parking bays could be provided throughout the study area within the highway verge/footway. This is around $[200/232=]$ 85% of the surveyed parking demand across the study area.
16. The following **Table 6** compares the potential verge parking capacity against the demand from the parking surveys.

Table 6 – Parking Demand Potentially Off-set by Verge Parking

Location	Total Parking Demand	Potential Creation of Verge/Footway Parking Spaces	Surplus/Deficit	% Demand of Availability
Zone 1	7	12	5	58%
Zone 2	4	8	4	50%
Zone 3	76	59	-17	129%
Zone 4	70	42	-28	167%
Zone 5	28	23	-5	122%
Zone 6	13	17	4	76%
Zone 7	18	12	-6	150%
Zone 8	17	24	7	71%
Total	233	197	-	118%

17. From this Table it can be seen that a flexible approach may need to be applied to the supply of verge parking, with around 50% of potential supply provided in some areas and closer to 75% to 100% created in other areas. The site access arrangement proposed for the Poplars Avenue (west) access also proposes to formalise the parking in that area, with the creation of additional parking spaces.
18. It should be noted that an element of the parking demand survey figures will be vehicles parked in the highway verge directly in front of driveways, perpendicular to the carriageway. As such, this level of demand cannot be taken into account in the calculations, beyond a statement that not all of the vehicles counted in the survey as 'informally parked' could be offset by proposed verge parking.
19. Any proposed verge parking measures will not impact on this practice of parking in the wide highway verge perpendicular to the carriageway in front of driveways in any event.

20. It is anticipated that all parking bays would be constructed using low impact methods to ensure limited impact on the highway trees, with cellular structure to permit grass growth for a reduced impact on the visual character of the area. Construction methods and materials to be agreed with the Council and their Arboricultural officer.

Speed Limit

21. As a result of creating more off-carriageway formalised parking, less vehicles would park on-street within the study area, subsequently increasing highway capacity. Whilst the free flow of traffic is beneficial in terms of capacity and reductions in vehicle emissions, this could increase vehicle speeds and impact pedestrian movements.
22. To counteract this, an extension to 20mph speed limit that already exists on a northern section of Poplars Avenue has been proposed on the rest of Poplars Avenue and the northern section of Capesthorpe Road between Poplars Avenue and Blackbrook Avenue. The area for potential extension to the 20mph speed restriction is shown in **Appendix 3**. This will assist in terms of highway and pedestrian safety.
23. The extension to the 20mph speed restriction would include six of the eight parking survey zones (3, 4, 5, 6, 7 and 8).
24. The impact of development traffic flows has been set out in TN/09.

Traffic Calming and Pedestrian Safety

25. Existing traffic calming on Capesthorpe Road comprises speed cushions and road humps. Speed cushions are also located on Greenwood Crescent. It is also recognised that there are a lack of modern pedestrian crossing facilities within the study area, with many lacking tactile paving, dropped kerbs or even a safe landing zone on the opposite side of the carriageway i.e. a pedestrian route one side of the road aligned with a full-height kerb and a grass verge on the other. There is also little in the way of provision for cyclists and/or measures to highlight the presence of cycles or that encourage cyclists. Current discussions are being held with highway officers to identify the most appropriate measures that could be brought forward and it is anticipated that a financial contribution will be provided to improve the existing situation.
26. The following list of measures have been considered alongside the verge parking to support the proposed extension to the 20mph speed limit and enhance awareness of the character of the area to through-traffic:
 - i. Raised tables at junctions (these can be virtual (painted) rather than physical depending on local constraints).
 - ii. Removal of centre line markings on sections of roads subject to a 20mph speed limit (retained at junctions unless raised tables installed).
 - iii. Increase person presence through the installation of street furniture such as benches for residents to sit on.
 - iv. Provision of signing/lining to enhance awareness of cyclists to drivers (and pedestrians as necessary).
 - v. Additional pedestrian crossings and improving the existing crossing locations with dropped kerbs and tactile paving where appropriate.

- vi. Potential for additional planting throughout the area.
 - vii. Provision of road narrowing's to maintain low traffic speeds through the area (possibly provided in conjunction with additional planting).
 - viii. Consideration of the removal of vertical traffic calming such as road humps, to reduce impact of noise and emissions on local residents.
27. From the above it is clear that a range of parking and traffic calming measures to the area to the south of the Peel Hall site are available to address the Inspector's concerns regarding safety in general and pedestrian safety in particular. These will be developed in conjunction with the Council so that they can be secured as part of the appeal proposals.

Appendix 1

Parking Survey Data

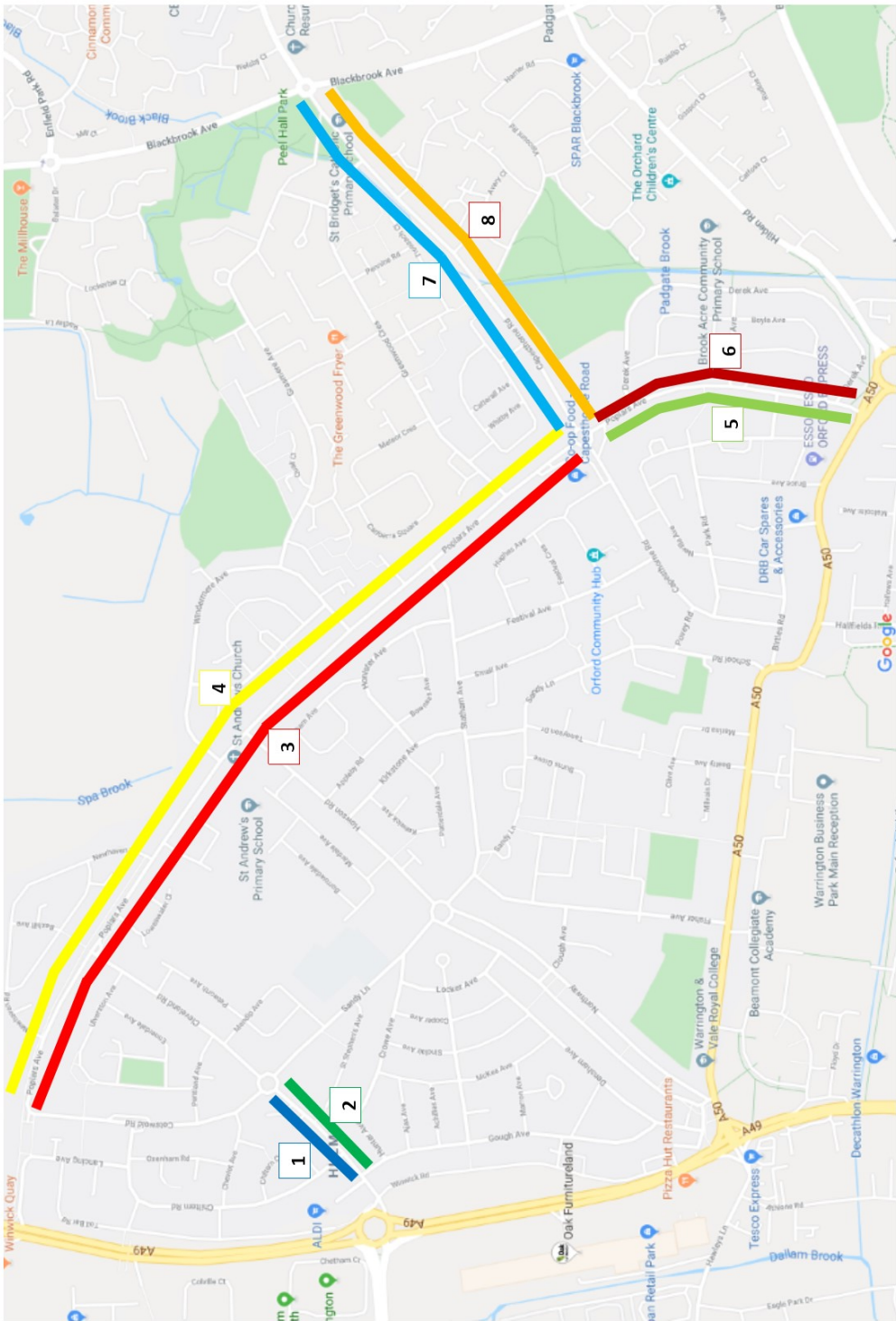

1

2

3

4

5

6

7

8

Warrington Parking Beat Survey

Location	Thursday 31st October 2019; 23:00		Saturday 2nd November 2019; 13:00	
	Total Spaces	Occupied	Total Spaces	Occupied
Zone 1	24	0	24	0
Zone 2	22	0	22	0
Zone 3	81	35	81	13
Zone 4	163	37	163	28
Zone 5	42	22	42	19
Zone 6	35	5	35	6
Zone 7	43	12	43	14
Zone 8	30	7	30	1
Total	440	118	440	81

Location	Thursday 31st October 2019; 23:00		Saturday 2nd November 2019; 13:00	
	Total Spaces	Parking Stress (%)	Total Spaces	Parking Stress (%)
Zone 1	24	0%	24	0%
Zone 2	22	0%	22	0%
Zone 3	81	43%	81	16%
Zone 4	163	23%	163	17%
Zone 5	42	52%	42	45%
Zone 6	35	14%	35	17%
Zone 7	43	28%	43	33%
Zone 8	30	23%	30	3%
Total	440	27%	440	18%

Location	Thursday 31st October 2019; 23:00		Saturday 2nd November 2019; 13:00	
	Total Spaces	Illegal Parking	Total Spaces	Illegal Parking
Zone 1	24	0	24	0
Zone 2	22	0	22	0
Zone 3	81	2	81	0
Zone 4	163	0	163	0
Zone 5	42	0	42	0
Zone 6	35	0	35	0
Zone 7	43	0	43	0
Zone 8	30	0	30	0
Total	440	2	440	0

Location	Thursday 31st October 2019; 23:00		Saturday 2nd November 2019; 13:00	
	Vehicles Parked on Grass Verges, Pavements and in front of Driveways with all 4 wheels off the road			
Zone 1	7		5	
Zone 2	4		1	
Zone 3	39		37	
Zone 4	33		26	
Zone 5	6		5	
Zone 6	8		3	
Zone 7	5		4	
Zone 8	10		7	
Total	112		88	

Location	Thursday 31st October 2019; 23:00				Saturday 2nd November 2019; 13:00			
	Spaces Occupied	Parked Informally	Illegally Parked	Total Parking Demand	Spaces Occupied	Parked Informally	Illegally Parked	Total Parking Demand
Zone 1	0	7	0	7	0	0	0	0
Zone 2	0	4	0	4	0	1	0	1
Zone 3	35	39	2	76	13	37	0	50
Zone 4	37	33	0	70	28	26	0	54
Zone 5	22	6	0	28	19	5	0	24
Zone 6	5	8	0	13	6	3	0	9
Zone 7	12	5	0	17	14	4	0	18
Zone 8	7	10	0	17	1	7	0	8
Total	118	112	2	232	81	88	0	169

Appendix 2

Potential Locations for Verge Parking

NOTES:
 © Crown Copyright and database rights 2019 OS Licence 100056454.
 Reproduced by Starfields by permission of Ordnance Survey® on behalf of the Controller of Her Majesty's Stationery Office.

Key

- Study area to be considered for off-carriageway formalised parking
- Potential locations for verge parking
- Indicative only - based on on-site observations

ISSUE	REASON FOR REVISION	DATE

PROJECT: **PEEL HALL, WARRINGTON**

CLIENT: **SATNAM MILLENNIUM LTD**

PROJECT REFERENCE	DRAWING NUMBER	SCALE
1901	06	Not to Scale

HighgateTransportation
 www.highgatetransportation.co.uk
 First Floor, 43-45 Park Street
 Bristol BS1 5NL
 07973 375 937 / 07595 892 217
 © Highgate Transportation Limited

TITLE: **POTENTIAL AREAS TO BE CONSIDERED FOR VERGE/FOOTWAY PARKING**

DATE:	DRAWN BY:	CHECKED:
29/01/20	FB	DT

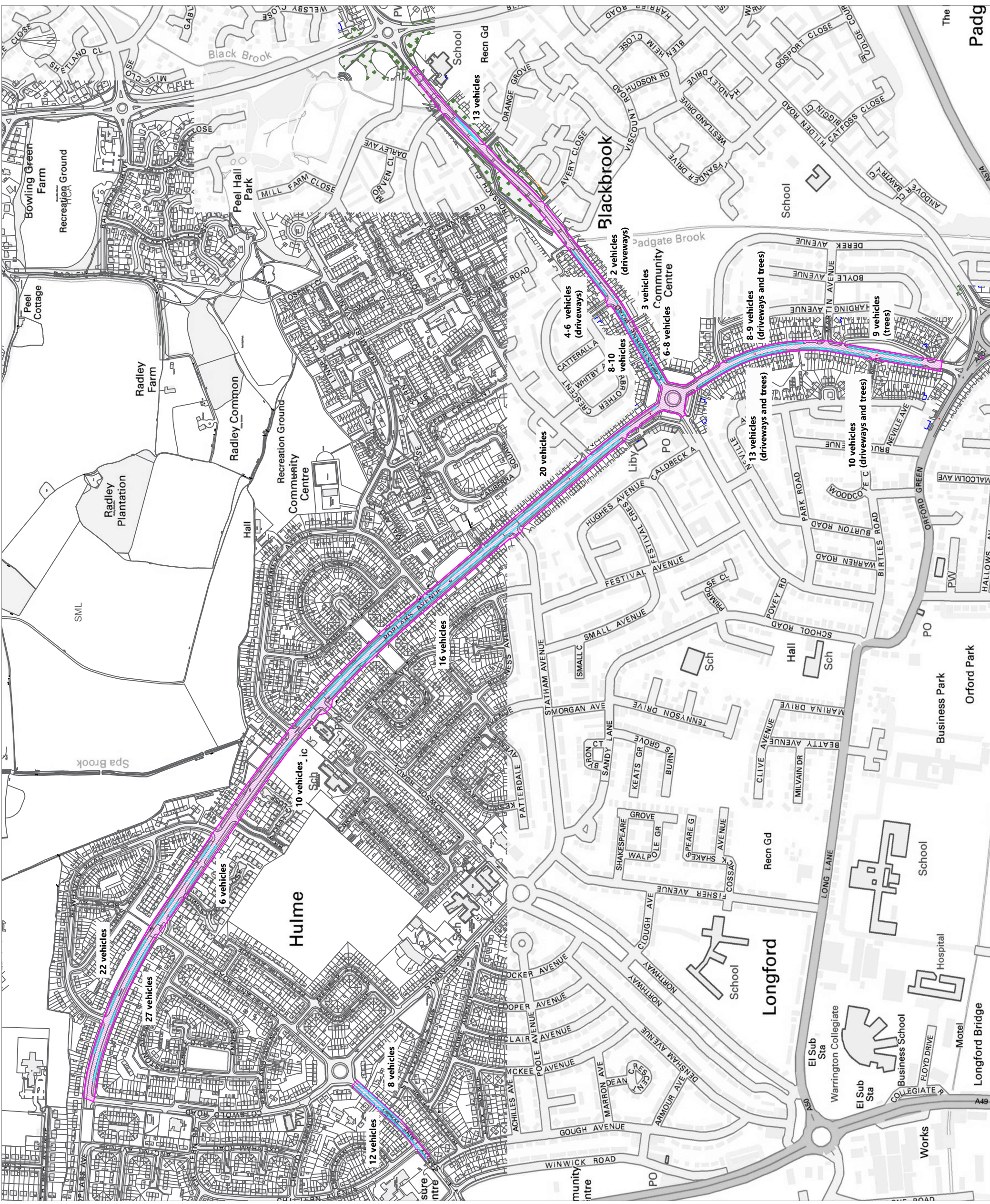

The Padg
 Business Park
 Orford Park
 Longford Bridge
 Works
 El Sub Sta
 Warrington Collegiate
 El Sub Sta
 Business School
 Hospital
 Motel
 A49

Appendix 3

Potential Extent of 20mph Speed Limit Extension

NOTES:
 © Crown Copyright and database rights 2019 OS Licence 100056454.
 Reproduced by Stanfords by permission of Ordnance Survey® on behalf of the Controller of Her Majesty's Stationery Office.

Proposed 20mph restriction to tie into existing 20mph restrictions where present.

Key

Potential 20mph speed restriction extension

ISSUE	REASON FOR REVISION	DATE



PROJECT:
**PEEL HALL,
 WARRINGTON**

CLIENT:
**SATNAM MILLENNIUM
 LTD**

PROJECT REFERENCE: 1901	DRAWING NUMBER: 07	SCALE: Not to Scale
----------------------------	-----------------------	------------------------

HighgateTransportation
 www.highgatetransportation.co.uk
 First Floor, 43-45 Park Street
 Bristol BS1 5NL
 07973 375 937 / 07595 892 217
 © Highgate Transportation Limited

TITLE:
**AREA FOR POTENTIAL 20MPH
 SPEED RESTRICTION EXTENSION**

DATE: 20/01/20	DRAWN BY: FB	CHECKED: DT
-------------------	-----------------	----------------

Junctions 9

ARCADY 9 - Roundabout Module

Version: 9.5.1.7462
© Copyright TRL Limited, 2019

For sales and distribution information, program advice and maintenance, contact TRL:
+44 (0)1344 379777 software@trl.co.uk www.trlsoftware.co.uk

The users of this computer program for the solution of an engineering problem are in no way relieved of their responsibility for the correctness of the solution

Filename: 1901 050320 Mill L BBrook A New Rb.j9

Path: C:\Users\Charlie\Highgate Transportation\HTp - 1901 - Peel Hall\Modelling\Site Access Junctions\CJ\Option A\Mill Lane_Blackbrook_Site\050320 Site Access Blackbrook Avenue

Report generation date: 05/03/2020 09:51:54

- »2022 Do Something, AM
- »2022 Do Something, PM
- »2022 Do Something (FULL), AM
- »2022 Do Something (FULL), PM
- »2027 Do Something, AM
- »2027 Do Something, PM
- »2032 Do Something (FULL), AM
- »2032 Do Something (FULL), PM

Summary of junction performance

	AM					PM				
	Set ID	Queue (Veh)	Delay (s)	RFC	LOS	Set ID	Queue (Veh)	Delay (s)	RFC	LOS
2022 Do Something										
Arm 1	D1	0.6	3.64	0.38	A	D2	0.5	3.31	0.31	A
Arm 2		0.2	1.90	0.19	A		0.3	1.94	0.20	A
Arm 3		0.0	0.00	0.00	A		0.0	0.00	0.00	A
2022 Do Something (FULL)										
Arm 1	D3	1.0	5.27	0.50	A	D4	0.7	4.08	0.40	A
Arm 2		0.4	2.19	0.28	A		0.6	2.51	0.38	A
Arm 3		0.5	4.16	0.34	A		0.2	3.51	0.20	A
2027 Do Something										
Arm 1	D5	0.9	4.45	0.47	A	D6	0.6	3.73	0.38	A
Arm 2		0.3	2.02	0.23	A		0.5	2.26	0.31	A
Arm 3		0.1	3.17	0.12	A		0.1	3.16	0.08	A
2032 Do Something (FULL)										
Arm 1	D7	1.3	6.20	0.57	A	D8	0.8	4.35	0.43	A
Arm 2		0.4	2.24	0.30	A		0.7	2.67	0.41	A
Arm 3		0.5	4.27	0.35	A		0.3	3.69	0.21	A

There are warnings associated with one or more model runs - see the 'Data Errors and Warnings' tables for each Analysis or Demand Set.

Values shown are the highest values encountered over all time segments. Delay is the maximum value of average delay per arriving vehicle.

File summary

File Description

Title	(untitled)
Location	
Site number	
Date	18/05/2016
Version	
Status	(new file)
Identifier	
Client	
Jobnumber	
Enumerator	DESKTOP-MD9GBJC\Fiona
Description	

Units

Distance units	Speed units	Traffic units input	Traffic units results	Flow units	Average delay units	Total delay units	Rate of delay units
m	kph	Veh	Veh	perHour	s	-Min	perMin

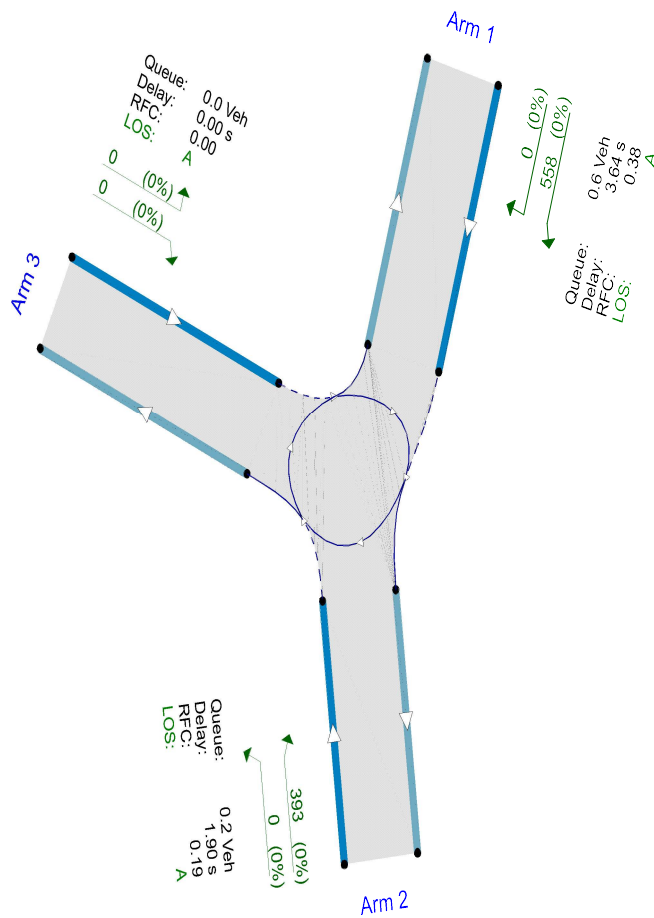

The junction diagram reflects the last run of Junctions.

Analysis Options

Calculate Queue Percentiles	Calculate residual capacity	RFC Threshold	Average Delay threshold (s)	Queue threshold (PCU)
✓		0.85	36.00	20.00

Demand Set Summary

ID	Scenario name	Time Period name	Traffic profile type	Start time (HH:mm)	Finish time (HH:mm)	Time segment length (min)
D1	2022 Do Something	AM	ONE HOUR	07:45	09:15	15
D2	2022 Do Something	PM	ONE HOUR	16:45	18:15	15
D3	2022 Do Something (FULL)	AM	ONE HOUR	07:45	09:15	15
D4	2022 Do Something (FULL)	PM	ONE HOUR	16:45	18:15	15
D5	2027 Do Something	AM	ONE HOUR	07:45	09:15	15
D6	2027 Do Something	PM	ONE HOUR	16:45	18:15	15
D7	2032 Do Something (FULL)	AM	ONE HOUR	07:45	09:15	15
D8	2032 Do Something (FULL)	PM	ONE HOUR	16:45	18:15	15

Analysis Set Details

ID	Network flow scaling factor (%)
A1	100.000

2022 Do Something, AM

Data Errors and Warnings

Severity	Area	Item	Description
Warning	Vehicle Mix		HV% is zero for all movements / time segments. Vehicle Mix matrix should be completed whether working in PCUs or Vehs. If HV% at the junction is genuinely zero, please ignore this warning.
Warning	Queue variations	Analysis Options	Queue percentiles may be unreliable if the mean queue in any time segment is very low or very high.

Junction Network

Junctions

Junction	Name	Junction type	Use circulating lanes	Arm order	Junction Delay (s)	Junction LOS
1	untitled	Standard Roundabout		1, 2, 3	2.92	A

Junction Network Options

Driving side	Lighting
Left	Normal/unknown

Arms

Arms

Arm	Name	Description
1	Mill Lane (N)	
2	Mill Lane (S)	
3	Site Access	

Roundabout Geometry

Arm	V - Approach road half-width (m)	E - Entry width (m)	I' - Effective flare length (m)	R - Entry radius (m)	D - Inscribed circle diameter (m)	PHI - Conflict (entry) angle (deg)	Exit only
1	3.50	7.80	10.0	20.0	36.0	31.0	
2	7.00	8.00	10.0	30.0	36.0	38.0	
3	3.65	7.35	20.0	11.0	36.0	56.0	

Slope / Intercept / Capacity

Roundabout Slope and Intercept used in model

Arm	Final slope	Final intercept (PCU/hr)
1	0.629	1603
2	0.772	2324
3	0.585	1574

The slope and intercept shown above include any corrections and adjustments.

Traffic Demand

Demand Set Details

ID	Scenario name	Time Period name	Traffic profile type	Start time (HH:mm)	Finish time (HH:mm)	Time segment length (min)
D1	2022 Do Something	AM	ONE HOUR	07:45	09:15	15

Vehicle mix source	PCU Factor for a HV (PCU)
HV Percentages	2.00

Demand overview (Traffic)

Arm	Linked arm	Use O-D data	Average Demand (Veh/hr)	Scaling Factor (%)
1		✓	558	100.000
2		✓	393	100.000
3		✓	0	100.000

Origin-Destination Data

Demand (Veh/hr)

		To		
		1	2	3
From	1	0	558	0
	2	393	0	0
	3	0	0	0

Vehicle Mix

Heavy Vehicle Percentages

		To		
		1	2	3
From	1	0	0	0
	2	0	0	0
	3	0	0	0

Results

Results Summary for whole modelled period

Arm	Max RFC	Max Delay (s)	Max Queue (Veh)	Max 95th percentile Queue (Veh)	Max LOS
1	0.38	3.64	0.6	2.6	A
2	0.19	1.90	0.2	0.5	A
3	0.00	0.00	0.0	~1	A

Main Results for each time segment

07:45 - 08:00

Arm	Total Demand (Veh/hr)	Circulating flow (Veh/hr)	Capacity (Veh/hr)	RFC	Throughput (Veh/hr)	End queue (Veh)	Delay (s)	Unsignalised level of service
1	420	0	1603	0.262	419	0.4	3.034	A
2	296	0	2324	0.127	295	0.1	1.774	A
3	0	295	1402	0.000	0	0.0	0.000	A

08:00 - 08:15

Arm	Total Demand (Veh/hr)	Circulating flow (Veh/hr)	Capacity (Veh/hr)	RFC	Throughput (Veh/hr)	End queue (Veh)	Delay (s)	Unsignalised level of service
1	502	0	1603	0.313	501	0.5	3.267	A
2	353	0	2324	0.152	353	0.2	1.826	A
3	0	353	1368	0.000	0	0.0	0.000	A

08:15 - 08:30

Arm	Total Demand (Veh/hr)	Circulating flow (Veh/hr)	Capacity (Veh/hr)	RFC	Throughput (Veh/hr)	End queue (Veh)	Delay (s)	Unsignalised level of service
1	614	0	1603	0.383	614	0.6	3.636	A
2	433	0	2324	0.186	433	0.2	1.902	A
3	0	433	1322	0.000	0	0.0	0.000	A

08:30 - 08:45

Arm	Total Demand (Veh/hr)	Circulating flow (Veh/hr)	Capacity (Veh/hr)	RFC	Throughput (Veh/hr)	End queue (Veh)	Delay (s)	Unsignalised level of service
1	614	0	1603	0.383	614	0.6	3.639	A
2	433	0	2324	0.186	433	0.2	1.902	A
3	0	433	1321	0.000	0	0.0	0.000	A

08:45 - 09:00

Arm	Total Demand (Veh/hr)	Circulating flow (Veh/hr)	Capacity (Veh/hr)	RFC	Throughput (Veh/hr)	End queue (Veh)	Delay (s)	Unsignalised level of service
1	502	0	1603	0.313	502	0.5	3.270	A
2	353	0	2324	0.152	353	0.2	1.829	A
3	0	353	1368	0.000	0	0.0	0.000	A

09:00 - 09:15

Arm	Total Demand (Veh/hr)	Circulating flow (Veh/hr)	Capacity (Veh/hr)	RFC	Throughput (Veh/hr)	End queue (Veh)	Delay (s)	Unsignalised level of service
1	420	0	1603	0.262	420	0.4	3.044	A
2	296	0	2324	0.127	296	0.1	1.774	A
3	0	296	1401	0.000	0	0.0	0.000	A

Queue Variation Results for each time segment**07:45 - 08:00**

Arm	Mean (Veh)	Q05 (Veh)	Q50 (Veh)	Q90 (Veh)	Q95 (Veh)	Percentile message	Marker message	Probability of reaching or exceeding marker	Probability of exactly reaching marker
1	0.35	0.00	0.00	0.35	0.35			N/A	N/A
2	0.15	0.00	0.00	0.15	0.15			N/A	N/A
3	0.00	0.00	0.00	0.00	0.00			N/A	N/A

08:00 - 08:15

Arm	Mean (Veh)	Q05 (Veh)	Q50 (Veh)	Q90 (Veh)	Q95 (Veh)	Percentile message	Marker message	Probability of reaching or exceeding marker	Probability of exactly reaching marker
1	0.45	0.00	0.00	0.45	0.45			N/A	N/A
2	0.18	0.00	0.00	0.18	0.18			N/A	N/A
3	0.00	0.00	0.00	0.00	0.00			N/A	N/A

08:15 - 08:30

Arm	Mean (Veh)	Q05 (Veh)	Q50 (Veh)	Q90 (Veh)	Q95 (Veh)	Percentile message	Marker message	Probability of reaching or exceeding marker	Probability of exactly reaching marker
1	0.62	0.03	0.25	0.62	0.62			N/A	N/A
2	0.23	0.03	0.25	0.45	0.48			N/A	N/A
3	0.00	0.00	0.00	0.00	0.00			N/A	N/A

08:30 - 08:45

Arm	Mean (Veh)	Q05 (Veh)	Q50 (Veh)	Q90 (Veh)	Q95 (Veh)	Percentile message	Marker message	Probability of reaching or exceeding marker	Probability of exactly reaching marker
1	0.62	0.03	0.29	1.03	2.62			N/A	N/A
2	0.23	0.03	0.25	0.45	0.48			N/A	N/A
3	0.00	0.00	0.00	0.00	0.00			N/A	N/A

08:45 - 09:00

Arm	Mean (Veh)	Q05 (Veh)	Q50 (Veh)	Q90 (Veh)	Q95 (Veh)	Percentile message	Marker message	Probability of reaching or exceeding marker	Probability of exactly reaching marker
1	0.46	0.00	0.00	0.46	0.46			N/A	N/A
2	0.18	0.00	0.00	0.18	0.18			N/A	N/A
3	0.00	0.00	0.00	0.00	0.00			N/A	N/A

09:00 - 09:15

Arm	Mean (Veh)	Q05 (Veh)	Q50 (Veh)	Q90 (Veh)	Q95 (Veh)	Percentile message	Marker message	Probability of reaching or exceeding marker	Probability of exactly reaching marker
1	0.36	0.00	0.00	0.36	0.36			N/A	N/A
2	0.15	0.00	0.00	0.15	0.15			N/A	N/A
3	0.00	0.00	0.00	0.00	0.00			N/A	N/A

2022 Do Something, PM

Data Errors and Warnings

Severity	Area	Item	Description
Warning	Queue variations	Analysis Options	Queue percentiles may be unreliable if the mean queue in any time segment is very low or very high.

Junction Network

Junctions

Junction	Name	Junction type	Use circulating lanes	Arm order	Junction Delay (s)	Junction LOS
1	untitled	Standard Roundabout		1, 2, 3	2.65	A

Junction Network Options

Driving side	Lighting
Left	Normal/unknown

Traffic Demand

Demand Set Details

ID	Scenario name	Time Period name	Traffic profile type	Start time (HH:mm)	Finish time (HH:mm)	Time segment length (min)
D2	2022 Do Something	PM	ONE HOUR	16:45	18:15	15

Vehicle mix source	PCU Factor for a HV (PCU)
HV Percentages	2.00

Demand overview (Traffic)

Arm	Linked arm	Use O-D data	Average Demand (Veh/hr)	Scaling Factor (%)
1		✓	454	100.000
2		✓	428	100.000
3		✓	0	100.000

Origin-Destination Data

Demand (Veh/hr)

		To		
		1	2	3
From	1	0	454	0
	2	428	0	0
	3	0	0	0

Vehicle Mix

Heavy Vehicle Percentages

		To		
		1	2	3
From	1	0	1	0
	2	0	0	0
	3	0	0	0

Results

Results Summary for whole modelled period

Arm	Max RFC	Max Delay (s)	Max Queue (Veh)	Max 95th percentile Queue (Veh)	Max LOS
1	0.31	3.31	0.5	1.9	A
2	0.20	1.94	0.3	0.5	A
3	0.00	0.00	0.0	~1	A

Main Results for each time segment

16:45 - 17:00

Arm	Total Demand (Veh/hr)	Circulating flow (Veh/hr)	Capacity (Veh/hr)	RFC	Throughput (Veh/hr)	End queue (Veh)	Delay (s)	Unsignalised level of service
1	342	0	1587	0.215	341	0.3	2.885	A
2	322	0	2324	0.139	322	0.2	1.797	A
3	0	322	1386	0.000	0	0.0	0.000	A

17:00 - 17:15

Arm	Total Demand (Veh/hr)	Circulating flow (Veh/hr)	Capacity (Veh/hr)	RFC	Throughput (Veh/hr)	End queue (Veh)	Delay (s)	Unsignalised level of service
1	408	0	1587	0.257	408	0.3	3.052	A
2	385	0	2324	0.166	385	0.2	1.855	A
3	0	385	1350	0.000	0	0.0	0.000	A

17:15 - 17:30

Arm	Total Demand (Veh/hr)	Circulating flow (Veh/hr)	Capacity (Veh/hr)	RFC	Throughput (Veh/hr)	End queue (Veh)	Delay (s)	Unsignalised level of service
1	500	0	1587	0.315	499	0.5	3.306	A
2	471	0	2324	0.203	471	0.3	1.943	A
3	0	471	1299	0.000	0	0.0	0.000	A

17:30 - 17:45

Arm	Total Demand (Veh/hr)	Circulating flow (Veh/hr)	Capacity (Veh/hr)	RFC	Throughput (Veh/hr)	End queue (Veh)	Delay (s)	Unsignalised level of service
1	500	0	1587	0.315	500	0.5	3.309	A
2	471	0	2324	0.203	471	0.3	1.943	A
3	0	471	1299	0.000	0	0.0	0.000	A

17:45 - 18:00

Arm	Total Demand (Veh/hr)	Circulating flow (Veh/hr)	Capacity (Veh/hr)	RFC	Throughput (Veh/hr)	End queue (Veh)	Delay (s)	Unsignalised level of service
1	408	0	1587	0.257	409	0.3	3.056	A
2	385	0	2324	0.166	385	0.2	1.856	A
3	0	385	1349	0.000	0	0.0	0.000	A

18:00 - 18:15

Arm	Total Demand (Veh/hr)	Circulating flow (Veh/hr)	Capacity (Veh/hr)	RFC	Throughput (Veh/hr)	End queue (Veh)	Delay (s)	Unsignalised level of service
1	342	0	1587	0.215	342	0.3	2.893	A
2	322	0	2324	0.139	322	0.2	1.798	A
3	0	322	1386	0.000	0	0.0	0.000	A

Queue Variation Results for each time segment**16:45 - 17:00**

Arm	Mean (Veh)	Q05 (Veh)	Q50 (Veh)	Q90 (Veh)	Q95 (Veh)	Percentile message	Marker message	Probability of reaching or exceeding marker	Probability of exactly reaching marker
1	0.27	0.00	0.00	0.27	0.27			N/A	N/A
2	0.16	0.00	0.00	0.16	0.16			N/A	N/A
3	0.00	0.00	0.00	0.00	0.00			N/A	N/A

17:00 - 17:15

Arm	Mean (Veh)	Q05 (Veh)	Q50 (Veh)	Q90 (Veh)	Q95 (Veh)	Percentile message	Marker message	Probability of reaching or exceeding marker	Probability of exactly reaching marker
1	0.34	0.00	0.00	0.34	0.34			N/A	N/A
2	0.20	0.00	0.00	0.20	0.20			N/A	N/A
3	0.00	0.00	0.00	0.00	0.00			N/A	N/A

17:15 - 17:30

Arm	Mean (Veh)	Q05 (Veh)	Q50 (Veh)	Q90 (Veh)	Q95 (Veh)	Percentile message	Marker message	Probability of reaching or exceeding marker	Probability of exactly reaching marker
1	0.46	0.03	0.25	0.46	0.48			N/A	N/A
2	0.25	0.03	0.25	0.45	0.48			N/A	N/A
3	0.00	0.00	0.00	0.00	0.00			N/A	N/A

17:30 - 17:45

Arm	Mean (Veh)	Q05 (Veh)	Q50 (Veh)	Q90 (Veh)	Q95 (Veh)	Percentile message	Marker message	Probability of reaching or exceeding marker	Probability of exactly reaching marker
1	0.46	0.03	0.31	1.38	1.92			N/A	N/A
2	0.25	0.03	0.26	0.47	0.49			N/A	N/A
3	0.00	0.00	0.00	0.00	0.00			N/A	N/A

17:45 - 18:00

Arm	Mean (Veh)	Q05 (Veh)	Q50 (Veh)	Q90 (Veh)	Q95 (Veh)	Percentile message	Marker message	Probability of reaching or exceeding marker	Probability of exactly reaching marker
1	0.35	0.00	0.00	0.35	0.35			N/A	N/A
2	0.20	0.00	0.00	0.20	0.20			N/A	N/A
3	0.00	0.00	0.00	0.00	0.00			N/A	N/A

18:00 - 18:15

Arm	Mean (Veh)	Q05 (Veh)	Q50 (Veh)	Q90 (Veh)	Q95 (Veh)	Percentile message	Marker message	Probability of reaching or exceeding marker	Probability of exactly reaching marker
1	0.28	0.00	0.00	0.28	0.28			N/A	N/A
2	0.16	0.00	0.00	0.16	0.16			N/A	N/A
3	0.00	0.00	0.00	0.00	0.00			N/A	N/A

2022 Do Something (FULL), AM

Data Errors and Warnings

Severity	Area	Item	Description
Warning	Vehicle Mix		HV% is zero for all movements / time segments. Vehicle Mix matrix should be completed whether working in PCUs or Vehs. If HV% at the junction is genuinely zero, please ignore this warning.
Warning	Queue variations	Analysis Options	Queue percentiles may be unreliable if the mean queue in any time segment is very low or very high.

Junction Network

Junctions

Junction	Name	Junction type	Use circulating lanes	Arm order	Junction Delay (s)	Junction LOS
1	untitled	Standard Roundabout		1, 2, 3	3.86	A

Junction Network Options

Driving side	Lighting
Left	Normal/unknown

Traffic Demand

Demand Set Details

ID	Scenario name	Time Period name	Traffic profile type	Start time (HH:mm)	Finish time (HH:mm)	Time segment length (min)
D3	2022 Do Something (FULL)	AM	ONE HOUR	07:45	09:15	15

Vehicle mix source	PCU Factor for a HV (PCU)
HV Percentages	2.00

Demand overview (Traffic)

Arm	Linked arm	Use O-D data	Average Demand (Veh/hr)	Scaling Factor (%)
1		✓	620	100.000
2		✓	591	100.000
3		✓	406	100.000

Origin-Destination Data

Demand (Veh/hr)

		To		
		1	2	3
From	1	0	588	32
	2	408	0	183
	3	63	343	0

Vehicle Mix

Heavy Vehicle Percentages

		To		
		1	2	3
From	1	0	0	0
	2	0	0	0
	3	0	0	0

Results

Results Summary for whole modelled period

Arm	Max RFC	Max Delay (s)	Max Queue (Veh)	Max 95th percentile Queue (Veh)	Max LOS
1	0.50	5.27	1.0	1.6	A
2	0.28	2.19	0.4	1.2	A
3	0.34	4.16	0.5	2.4	A

Main Results for each time segment

07:45 - 08:00

Arm	Total Demand (Veh/hr)	Circulating flow (Veh/hr)	Capacity (Veh/hr)	RFC	Throughput (Veh/hr)	End queue (Veh)	Delay (s)	Unsignalised level of service
1	467	257	1441	0.324	465	0.5	3.681	A
2	445	24	2305	0.193	444	0.2	1.933	A
3	306	307	1395	0.219	305	0.3	3.298	A

08:00 - 08:15

Arm	Total Demand (Veh/hr)	Circulating flow (Veh/hr)	Capacity (Veh/hr)	RFC	Throughput (Veh/hr)	End queue (Veh)	Delay (s)	Unsignalised level of service
1	557	308	1409	0.395	557	0.6	4.218	A
2	531	29	2301	0.231	531	0.3	2.033	A
3	365	367	1360	0.268	365	0.4	3.616	A

08:15 - 08:30

Arm	Total Demand (Veh/hr)	Circulating flow (Veh/hr)	Capacity (Veh/hr)	RFC	Throughput (Veh/hr)	End queue (Veh)	Delay (s)	Unsignalised level of service
1	683	377	1366	0.500	681	1.0	5.247	A
2	651	35	2296	0.283	650	0.4	2.187	A
3	447	449	1312	0.341	446	0.5	4.157	A

08:30 - 08:45

Arm	Total Demand (Veh/hr)	Circulating flow (Veh/hr)	Capacity (Veh/hr)	RFC	Throughput (Veh/hr)	End queue (Veh)	Delay (s)	Unsignalised level of service
1	683	378	1366	0.500	683	1.0	5.270	A
2	651	35	2296	0.283	651	0.4	2.187	A
3	447	449	1312	0.341	447	0.5	4.162	A

08:45 - 09:00

Arm	Total Demand (Veh/hr)	Circulating flow (Veh/hr)	Capacity (Veh/hr)	RFC	Throughput (Veh/hr)	End queue (Veh)	Delay (s)	Unsignalised level of service
1	557	309	1409	0.396	559	0.7	4.240	A
2	531	29	2301	0.231	532	0.3	2.034	A
3	365	367	1360	0.268	366	0.4	3.622	A

09:00 - 09:15

Arm	Total Demand (Veh/hr)	Circulating flow (Veh/hr)	Capacity (Veh/hr)	RFC	Throughput (Veh/hr)	End queue (Veh)	Delay (s)	Unsignalised level of service
1	467	259	1441	0.324	467	0.5	3.704	A
2	445	24	2305	0.193	445	0.2	1.937	A
3	306	307	1395	0.219	306	0.3	3.309	A

Queue Variation Results for each time segment**07:45 - 08:00**

Arm	Mean (Veh)	Q05 (Veh)	Q50 (Veh)	Q90 (Veh)	Q95 (Veh)	Percentile message	Marker message	Probability of reaching or exceeding marker	Probability of exactly reaching marker
1	0.48	0.00	0.00	0.48	0.48			N/A	N/A
2	0.24	0.00	0.00	0.24	0.24			N/A	N/A
3	0.28	0.00	0.00	0.28	0.28			N/A	N/A

08:00 - 08:15

Arm	Mean (Veh)	Q05 (Veh)	Q50 (Veh)	Q90 (Veh)	Q95 (Veh)	Percentile message	Marker message	Probability of reaching or exceeding marker	Probability of exactly reaching marker
1	0.65	0.10	0.83	1.37	1.43			N/A	N/A
2	0.30	0.00	0.00	0.30	0.30			N/A	N/A
3	0.36	0.00	0.00	0.36	0.36			N/A	N/A

08:15 - 08:30

Arm	Mean (Veh)	Q05 (Veh)	Q50 (Veh)	Q90 (Veh)	Q95 (Veh)	Percentile message	Marker message	Probability of reaching or exceeding marker	Probability of exactly reaching marker
1	0.99	0.03	0.26	0.99	0.99			N/A	N/A
2	0.39	0.03	0.25	0.45	0.48			N/A	N/A
3	0.51	0.03	0.25	0.51	0.51			N/A	N/A

08:30 - 08:45

Arm	Mean (Veh)	Q05 (Veh)	Q50 (Veh)	Q90 (Veh)	Q95 (Veh)	Percentile message	Marker message	Probability of reaching or exceeding marker	Probability of exactly reaching marker
1	0.99	0.03	0.27	0.99	1.63			N/A	N/A
2	0.39	0.03	0.33	1.19	1.19			N/A	N/A
3	0.52	0.03	0.30	1.38	2.36			N/A	N/A

08:45 - 09:00

Arm	Mean (Veh)	Q05 (Veh)	Q50 (Veh)	Q90 (Veh)	Q95 (Veh)	Percentile message	Marker message	Probability of reaching or exceeding marker	Probability of exactly reaching marker
1	0.66	0.30	0.95	1.39	1.45			N/A	N/A
2	0.30	0.00	0.00	0.30	0.30			N/A	N/A
3	0.37	0.00	0.00	0.37	0.37			N/A	N/A

09:00 - 09:15

Arm	Mean (Veh)	Q05 (Veh)	Q50 (Veh)	Q90 (Veh)	Q95 (Veh)	Percentile message	Marker message	Probability of reaching or exceeding marker	Probability of exactly reaching marker
1	0.48	0.04	0.42	1.25	1.38			N/A	N/A
2	0.24	0.00	0.00	0.24	0.24			N/A	N/A
3	0.28	0.00	0.00	0.28	0.28			N/A	N/A

2022 Do Something (FULL), PM

Data Errors and Warnings

Severity	Area	Item	Description
Warning	Vehicle Mix		HV% is zero for all movements / time segments. Vehicle Mix matrix should be completed whether working in PCUs or Vehs. If HV% at the junction is genuinely zero, please ignore this warning.
Warning	Queue variations	Analysis Options	Queue percentiles may be unreliable if the mean queue in any time segment is very low or very high.

Junction Network

Junctions

Junction	Name	Junction type	Use circulating lanes	Arm order	Junction Delay (s)	Junction LOS
1	untitled	Standard Roundabout		1, 2, 3	3.20	A

Junction Network Options

Driving side	Lighting
Left	Normal/unknown

Traffic Demand

Demand Set Details

ID	Scenario name	Time Period name	Traffic profile type	Start time (HH:mm)	Finish time (HH:mm)	Time segment length (min)
D4	2022 Do Something (FULL)	PM	ONE HOUR	16:45	18:15	15

Vehicle mix source	PCU Factor for a HV (PCU)
HV Percentages	2.00

Demand overview (Traffic)

Arm	Linked arm	Use O-D data	Average Demand (Veh/hr)	Scaling Factor (%)
1		✓	529	100.000
2		✓	782	100.000
3		✓	229	100.000

Origin-Destination Data

Demand (Veh/hr)

		To		
		1	2	3
From	1	0	494	35
	2	460	0	322
	3	29	200	0

Vehicle Mix

Heavy Vehicle Percentages

		To		
		1	2	3
From	1	0	0	0
	2	0	0	0
	3	0	0	0

Results

Results Summary for whole modelled period

Arm	Max RFC	Max Delay (s)	Max Queue (Veh)	Max 95th percentile Queue (Veh)	Max LOS
1	0.40	4.08	0.7	2.7	A
2	0.38	2.51	0.6	2.7	A
3	0.20	3.51	0.2	0.8	A

Main Results for each time segment

16:45 - 17:00

Arm	Total Demand (Veh/hr)	Circulating flow (Veh/hr)	Capacity (Veh/hr)	RFC	Throughput (Veh/hr)	End queue (Veh)	Delay (s)	Unsignalised level of service
1	398	150	1509	0.264	397	0.4	3.233	A
2	589	26	2303	0.256	587	0.3	2.096	A
3	172	346	1372	0.126	172	0.1	2.996	A

17:00 - 17:15

Arm	Total Demand (Veh/hr)	Circulating flow (Veh/hr)	Capacity (Veh/hr)	RFC	Throughput (Veh/hr)	End queue (Veh)	Delay (s)	Unsignalised level of service
1	476	180	1490	0.319	475	0.5	3.544	A
2	703	31	2299	0.306	703	0.4	2.254	A
3	206	413	1333	0.154	206	0.2	3.193	A

17:15 - 17:30

Arm	Total Demand (Veh/hr)	Circulating flow (Veh/hr)	Capacity (Veh/hr)	RFC	Throughput (Veh/hr)	End queue (Veh)	Delay (s)	Unsignalised level of service
1	582	220	1465	0.398	582	0.7	4.073	A
2	861	38	2294	0.375	860	0.6	2.509	A
3	252	506	1279	0.197	252	0.2	3.506	A

17:30 - 17:45

Arm	Total Demand (Veh/hr)	Circulating flow (Veh/hr)	Capacity (Veh/hr)	RFC	Throughput (Veh/hr)	End queue (Veh)	Delay (s)	Unsignalised level of service
1	582	220	1465	0.398	582	0.7	4.080	A
2	861	39	2294	0.375	861	0.6	2.512	A
3	252	506	1278	0.197	252	0.2	3.507	A

17:45 - 18:00

Arm	Total Demand (Veh/hr)	Circulating flow (Veh/hr)	Capacity (Veh/hr)	RFC	Throughput (Veh/hr)	End queue (Veh)	Delay (s)	Unsignalised level of service
1	476	180	1490	0.319	476	0.5	3.555	A
2	703	32	2299	0.306	704	0.4	2.256	A
3	206	414	1332	0.155	206	0.2	3.198	A

18:00 - 18:15

Arm	Total Demand (Veh/hr)	Circulating flow (Veh/hr)	Capacity (Veh/hr)	RFC	Throughput (Veh/hr)	End queue (Veh)	Delay (s)	Unsignalised level of service
1	398	151	1508	0.264	399	0.4	3.247	A
2	589	26	2303	0.256	589	0.3	2.100	A
3	172	347	1372	0.126	173	0.1	3.001	A

Queue Variation Results for each time segment**16:45 - 17:00**

Arm	Mean (Veh)	Q05 (Veh)	Q50 (Veh)	Q90 (Veh)	Q95 (Veh)	Percentile message	Marker message	Probability of reaching or exceeding marker	Probability of exactly reaching marker
1	0.36	0.00	0.00	0.36	0.36			N/A	N/A
2	0.34	0.00	0.00	0.34	0.34			N/A	N/A
3	0.14	0.00	0.00	0.14	0.14			N/A	N/A

17:00 - 17:15

Arm	Mean (Veh)	Q05 (Veh)	Q50 (Veh)	Q90 (Veh)	Q95 (Veh)	Percentile message	Marker message	Probability of reaching or exceeding marker	Probability of exactly reaching marker
1	0.47	0.00	0.00	0.47	0.47			N/A	N/A
2	0.44	0.00	0.00	0.44	0.44			N/A	N/A
3	0.18	0.00	0.00	0.18	0.18			N/A	N/A

17:15 - 17:30

Arm	Mean (Veh)	Q05 (Veh)	Q50 (Veh)	Q90 (Veh)	Q95 (Veh)	Percentile message	Marker message	Probability of reaching or exceeding marker	Probability of exactly reaching marker
1	0.66	0.03	0.25	0.66	0.66			N/A	N/A
2	0.60	0.03	0.25	0.60	0.60			N/A	N/A
3	0.24	0.03	0.25	0.46	0.48			N/A	N/A

17:30 - 17:45

Arm	Mean (Veh)	Q05 (Veh)	Q50 (Veh)	Q90 (Veh)	Q95 (Veh)	Percentile message	Marker message	Probability of reaching or exceeding marker	Probability of exactly reaching marker
1	0.66	0.03	0.28	0.93	2.68			N/A	N/A
2	0.60	0.03	0.29	1.21	2.71			N/A	N/A
3	0.25	0.03	0.27	0.48	0.79			N/A	N/A

17:45 - 18:00

Arm	Mean (Veh)	Q05 (Veh)	Q50 (Veh)	Q90 (Veh)	Q95 (Veh)	Percentile message	Marker message	Probability of reaching or exceeding marker	Probability of exactly reaching marker
1	0.47	0.00	0.00	0.47	0.47			N/A	N/A
2	0.44	0.00	0.00	0.44	0.44			N/A	N/A
3	0.18	0.00	0.00	0.18	0.18			N/A	N/A

18:00 - 18:15

Arm	Mean (Veh)	Q05 (Veh)	Q50 (Veh)	Q90 (Veh)	Q95 (Veh)	Percentile message	Marker message	Probability of reaching or exceeding marker	Probability of exactly reaching marker
1	0.36	0.00	0.00	0.36	0.36			N/A	N/A
2	0.34	0.00	0.00	0.34	0.34			N/A	N/A
3	0.14	0.00	0.00	0.14	0.14			N/A	N/A

2027 Do Something, AM

Data Errors and Warnings

Severity	Area	Item	Description
Warning	Vehicle Mix		HV% is zero for all movements / time segments. Vehicle Mix matrix should be completed whether working in PCUs or Vehs. If HV% at the junction is genuinely zero, please ignore this warning.
Warning	Queue variations	Analysis Options	Queue percentiles may be unreliable if the mean queue in any time segment is very low or very high.

Junction Network

Junctions

Junction	Name	Junction type	Use circulating lanes	Arm order	Junction Delay (s)	Junction LOS
1	untitled	Standard Roundabout		1, 2, 3	3.38	A

Junction Network Options

Driving side	Lighting
Left	Normal/unknown

Traffic Demand

Demand Set Details

ID	Scenario name	Time Period name	Traffic profile type	Start time (HH:mm)	Finish time (HH:mm)	Time segment length (min)
D5	2027 Do Something	AM	ONE HOUR	07:45	09:15	15

Vehicle mix source	PCU Factor for a HV (PCU)
HV Percentages	2.00

Demand overview (Traffic)

Arm	Linked arm	Use O-D data	Average Demand (Veh/hr)	Scaling Factor (%)
1		✓	643	100.000
2		✓	486	100.000
3		✓	147	100.000

Origin-Destination Data

Demand (Veh/hr)

		To		
		1	2	3
From	1	0	634	9
	2	432	0	54
	3	22	125	0

Vehicle Mix

Heavy Vehicle Percentages

		To		
		1	2	3
From	1	0	0	0
	2	0	0	0
	3	0	0	0

Results

Results Summary for whole modelled period

Arm	Max RFC	Max Delay (s)	Max Queue (Veh)	Max 95th percentile Queue (Veh)	Max LOS
1	0.47	4.45	0.9	1.8	A
2	0.23	2.02	0.3	1.2	A
3	0.12	3.17	0.1	0.5	A

Main Results for each time segment

07:45 - 08:00

Arm	Total Demand (Veh/hr)	Circulating flow (Veh/hr)	Capacity (Veh/hr)	RFC	Throughput (Veh/hr)	End queue (Veh)	Delay (s)	Unsignalised level of service
1	484	94	1544	0.313	482	0.5	3.384	A
2	366	7	2318	0.158	365	0.2	1.842	A
3	111	325	1385	0.080	110	0.1	2.825	A

08:00 - 08:15

Arm	Total Demand (Veh/hr)	Circulating flow (Veh/hr)	Capacity (Veh/hr)	RFC	Throughput (Veh/hr)	End queue (Veh)	Delay (s)	Unsignalised level of service
1	578	112	1533	0.377	577	0.6	3.767	A
2	437	8	2317	0.189	437	0.2	1.913	A
3	132	388	1347	0.098	132	0.1	2.961	A

08:15 - 08:30

Arm	Total Demand (Veh/hr)	Circulating flow (Veh/hr)	Capacity (Veh/hr)	RFC	Throughput (Veh/hr)	End queue (Veh)	Delay (s)	Unsignalised level of service
1	708	138	1517	0.467	707	0.9	4.440	A
2	535	10	2316	0.231	535	0.3	2.021	A
3	162	475	1296	0.125	162	0.1	3.172	A

08:30 - 08:45

Arm	Total Demand (Veh/hr)	Circulating flow (Veh/hr)	Capacity (Veh/hr)	RFC	Throughput (Veh/hr)	End queue (Veh)	Delay (s)	Unsignalised level of service
1	708	138	1517	0.467	708	0.9	4.451	A
2	535	10	2316	0.231	535	0.3	2.021	A
3	162	476	1296	0.125	162	0.1	3.172	A

08:45 - 09:00

Arm	Total Demand (Veh/hr)	Circulating flow (Veh/hr)	Capacity (Veh/hr)	RFC	Throughput (Veh/hr)	End queue (Veh)	Delay (s)	Unsignalised level of service
1	578	112	1532	0.377	579	0.6	3.782	A
2	437	8	2317	0.189	437	0.2	1.916	A
3	132	389	1347	0.098	132	0.1	2.962	A

09:00 - 09:15

Arm	Total Demand (Veh/hr)	Circulating flow (Veh/hr)	Capacity (Veh/hr)	RFC	Throughput (Veh/hr)	End queue (Veh)	Delay (s)	Unsignalised level of service
1	484	94	1544	0.314	485	0.5	3.399	A
2	366	7	2318	0.158	366	0.2	1.843	A
3	111	325	1384	0.080	111	0.1	2.826	A

Queue Variation Results for each time segment**07:45 - 08:00**

Arm	Mean (Veh)	Q05 (Veh)	Q50 (Veh)	Q90 (Veh)	Q95 (Veh)	Percentile message	Marker message	Probability of reaching or exceeding marker	Probability of exactly reaching marker
1	0.45	0.00	0.00	0.45	0.45			N/A	N/A
2	0.19	0.00	0.00	0.19	0.19			N/A	N/A
3	0.09	0.00	0.00	0.09	0.09			N/A	N/A

08:00 - 08:15

Arm	Mean (Veh)	Q05 (Veh)	Q50 (Veh)	Q90 (Veh)	Q95 (Veh)	Percentile message	Marker message	Probability of reaching or exceeding marker	Probability of exactly reaching marker
1	0.60	0.10	0.83	1.37	1.43			N/A	N/A
2	0.23	0.00	0.00	0.23	0.23			N/A	N/A
3	0.11	0.00	0.00	0.11	0.11			N/A	N/A

08:15 - 08:30

Arm	Mean (Veh)	Q05 (Veh)	Q50 (Veh)	Q90 (Veh)	Q95 (Veh)	Percentile message	Marker message	Probability of reaching or exceeding marker	Probability of exactly reaching marker
1	0.87	0.03	0.25	0.87	0.87			N/A	N/A
2	0.30	0.03	0.25	0.45	0.48			N/A	N/A
3	0.14	0.03	0.26	0.46	0.49			N/A	N/A

08:30 - 08:45

Arm	Mean (Veh)	Q05 (Veh)	Q50 (Veh)	Q90 (Veh)	Q95 (Veh)	Percentile message	Marker message	Probability of reaching or exceeding marker	Probability of exactly reaching marker
1	0.87	0.03	0.27	0.87	1.76			N/A	N/A
2	0.30	0.03	0.30	0.89	1.20			N/A	N/A
3	0.14	0.00	0.00	0.14	0.14			N/A	N/A

08:45 - 09:00

Arm	Mean (Veh)	Q05 (Veh)	Q50 (Veh)	Q90 (Veh)	Q95 (Veh)	Percentile message	Marker message	Probability of reaching or exceeding marker	Probability of exactly reaching marker
1	0.61	0.55	1.00	1.40	1.45			N/A	N/A
2	0.23	0.00	0.00	0.23	0.23			N/A	N/A
3	0.11	0.00	0.00	0.11	0.11			N/A	N/A

09:00 - 09:15

Arm	Mean (Veh)	Q05 (Veh)	Q50 (Veh)	Q90 (Veh)	Q95 (Veh)	Percentile message	Marker message	Probability of reaching or exceeding marker	Probability of exactly reaching marker
1	0.46	0.00	0.00	0.46	0.46			N/A	N/A
2	0.19	0.00	0.00	0.19	0.19			N/A	N/A
3	0.09	0.00	0.00	0.09	0.09			N/A	N/A

2027 Do Something, PM

Data Errors and Warnings

Severity	Area	Item	Description
Warning	Vehicle Mix		HV% is zero for all movements / time segments. Vehicle Mix matrix should be completed whether working in PCUs or Vehs. If HV% at the junction is genuinely zero, please ignore this warning.
Warning	Queue variations	Analysis Options	Queue percentiles may be unreliable if the mean queue in any time segment is very low or very high.

Junction Network

Junctions

Junction	Name	Junction type	Use circulating lanes	Arm order	Junction Delay (s)	Junction LOS
1	untitled	Standard Roundabout		1, 2, 3	2.94	A

Junction Network Options

Driving side	Lighting
Left	Normal/unknown

Traffic Demand

Demand Set Details

ID	Scenario name	Time Period name	Traffic profile type	Start time (HH:mm)	Finish time (HH:mm)	Time segment length (min)
D6	2027 Do Something	PM	ONE HOUR	16:45	18:15	15

Vehicle mix source	PCU Factor for a HV (PCU)
HV Percentages	2.00

Demand overview (Traffic)

Arm	Linked arm	Use O-D data	Average Demand (Veh/hr)	Scaling Factor (%)
1		✓	532	100.000
2		✓	655	100.000
3		✓	86	100.000

Origin-Destination Data

Demand (Veh/hr)

		To		
		1	2	3
From	1	0	518	14
	2	530	0	125
	3	9	77	0

Vehicle Mix

Heavy Vehicle Percentages

		To		
		1	2	3
From	1	0	0	0
	2	0	0	0
	3	0	0	0

Results

Results Summary for whole modelled period

Arm	Max RFC	Max Delay (s)	Max Queue (Veh)	Max 95th percentile Queue (Veh)	Max LOS
1	0.38	3.73	0.6	2.7	A
2	0.31	2.26	0.5	1.8	A
3	0.08	3.16	0.1	0.5	A

Main Results for each time segment

16:45 - 17:00

Arm	Total Demand (Veh/hr)	Circulating flow (Veh/hr)	Capacity (Veh/hr)	RFC	Throughput (Veh/hr)	End queue (Veh)	Delay (s)	Unsignalised level of service
1	401	58	1567	0.256	399	0.3	3.080	A
2	493	11	2315	0.213	492	0.3	1.973	A
3	65	398	1342	0.048	65	0.1	2.818	A

17:00 - 17:15

Arm	Total Demand (Veh/hr)	Circulating flow (Veh/hr)	Capacity (Veh/hr)	RFC	Throughput (Veh/hr)	End queue (Veh)	Delay (s)	Unsignalised level of service
1	478	69	1560	0.307	478	0.4	3.327	A
2	589	13	2314	0.254	589	0.3	2.086	A
3	77	476	1296	0.060	77	0.1	2.953	A

17:15 - 17:30

Arm	Total Demand (Veh/hr)	Circulating flow (Veh/hr)	Capacity (Veh/hr)	RFC	Throughput (Veh/hr)	End queue (Veh)	Delay (s)	Unsignalised level of service
1	586	85	1550	0.378	585	0.6	3.729	A
2	721	15	2312	0.312	721	0.5	2.262	A
3	95	583	1233	0.077	95	0.1	3.160	A

17:30 - 17:45

Arm	Total Demand (Veh/hr)	Circulating flow (Veh/hr)	Capacity (Veh/hr)	RFC	Throughput (Veh/hr)	End queue (Veh)	Delay (s)	Unsignalised level of service
1	586	85	1550	0.378	586	0.6	3.732	A
2	721	15	2312	0.312	721	0.5	2.263	A
3	95	584	1233	0.077	95	0.1	3.161	A

17:45 - 18:00

Arm	Total Demand (Veh/hr)	Circulating flow (Veh/hr)	Capacity (Veh/hr)	RFC	Throughput (Veh/hr)	End queue (Veh)	Delay (s)	Unsignalised level of service
1	478	69	1560	0.307	479	0.4	3.332	A
2	589	13	2314	0.254	589	0.3	2.089	A
3	77	477	1296	0.060	77	0.1	2.954	A

18:00 - 18:15

Arm	Total Demand (Veh/hr)	Circulating flow (Veh/hr)	Capacity (Veh/hr)	RFC	Throughput (Veh/hr)	End queue (Veh)	Delay (s)	Unsignalised level of service
1	401	58	1567	0.256	401	0.3	3.090	A
2	493	11	2315	0.213	493	0.3	1.975	A
3	65	399	1341	0.048	65	0.1	2.820	A

Queue Variation Results for each time segment**16:45 - 17:00**

Arm	Mean (Veh)	Q05 (Veh)	Q50 (Veh)	Q90 (Veh)	Q95 (Veh)	Percentile message	Marker message	Probability of reaching or exceeding marker	Probability of exactly reaching marker
1	0.34	0.00	0.00	0.34	0.34			N/A	N/A
2	0.27	0.00	0.00	0.27	0.27			N/A	N/A
3	0.05	0.00	0.00	0.05	0.05			N/A	N/A

17:00 - 17:15

Arm	Mean (Veh)	Q05 (Veh)	Q50 (Veh)	Q90 (Veh)	Q95 (Veh)	Percentile message	Marker message	Probability of reaching or exceeding marker	Probability of exactly reaching marker
1	0.44	0.00	0.00	0.44	0.44			N/A	N/A
2	0.34	0.00	0.00	0.34	0.34			N/A	N/A
3	0.06	0.03	0.25	0.45	0.48			N/A	N/A

17:15 - 17:30

Arm	Mean (Veh)	Q05 (Veh)	Q50 (Veh)	Q90 (Veh)	Q95 (Veh)	Percentile message	Marker message	Probability of reaching or exceeding marker	Probability of exactly reaching marker
1	0.60	0.03	0.25	0.60	0.60			N/A	N/A
2	0.45	0.03	0.25	0.45	0.48			N/A	N/A
3	0.08	0.03	0.26	0.47	0.49			N/A	N/A

17:30 - 17:45

Arm	Mean (Veh)	Q05 (Veh)	Q50 (Veh)	Q90 (Veh)	Q95 (Veh)	Percentile message	Marker message	Probability of reaching or exceeding marker	Probability of exactly reaching marker
1	0.61	0.03	0.29	1.12	2.66			N/A	N/A
2	0.45	0.03	0.32	1.40	1.80			N/A	N/A
3	0.08	0.00	0.00	0.08	0.08			N/A	N/A

17:45 - 18:00

Arm	Mean (Veh)	Q05 (Veh)	Q50 (Veh)	Q90 (Veh)	Q95 (Veh)	Percentile message	Marker message	Probability of reaching or exceeding marker	Probability of exactly reaching marker
1	0.44	0.00	0.00	0.44	0.44			N/A	N/A
2	0.34	0.00	0.00	0.34	0.34			N/A	N/A
3	0.06	0.00	0.00	0.06	0.06			N/A	N/A

18:00 - 18:15

Arm	Mean (Veh)	Q05 (Veh)	Q50 (Veh)	Q90 (Veh)	Q95 (Veh)	Percentile message	Marker message	Probability of reaching or exceeding marker	Probability of exactly reaching marker
1	0.34	0.00	0.00	0.34	0.34			N/A	N/A
2	0.27	0.00	0.00	0.27	0.27			N/A	N/A
3	0.05	0.00	0.00	0.05	0.05			N/A	N/A

2032 Do Something (FULL), AM

Data Errors and Warnings

Severity	Area	Item	Description
Warning	Vehicle Mix		HV% is zero for all movements / time segments. Vehicle Mix matrix should be completed whether working in PCUs or Vehs. If HV% at the junction is genuinely zero, please ignore this warning.
Warning	Queue variations	Analysis Options	Queue percentiles may be unreliable if the mean queue in any time segment is very low or very high.

Junction Network

Junctions

Junction	Name	Junction type	Use circulating lanes	Arm order	Junction Delay (s)	Junction LOS
1	untitled	Standard Roundabout		1, 2, 3	4.31	A

Junction Network Options

Driving side	Lighting
Left	Normal/unknown

Traffic Demand

Demand Set Details

ID	Scenario name	Time Period name	Traffic profile type	Start time (HH:mm)	Finish time (HH:mm)	Time segment length (min)
D7	2032 Do Something (FULL)	AM	ONE HOUR	07:45	09:15	15

Vehicle mix source	PCU Factor for a HV (PCU)
HV Percentages	2.00

Demand overview (Traffic)

Arm	Linked arm	Use O-D data	Average Demand (Veh/hr)	Scaling Factor (%)
1		✓	701	100.000
2		✓	627	100.000
3		✓	406	100.000

Origin-Destination Data

Demand (Veh/hr)

		To		
		1	2	3
From	1	0	672	29
	2	441	0	186
	3	44	362	0

Vehicle Mix

Heavy Vehicle Percentages

		To		
		1	2	3
From	1	0	0	0
	2	0	0	0
	3	0	0	0

Results

Results Summary for whole modelled period

Arm	Max RFC	Max Delay (s)	Max Queue (Veh)	Max 95th percentile Queue (Veh)	Max LOS
1	0.57	6.20	1.3	1.5	A
2	0.30	2.24	0.4	1.6	A
3	0.35	4.27	0.5	2.4	A

Main Results for each time segment

07:45 - 08:00

Arm	Total Demand (Veh/hr)	Circulating flow (Veh/hr)	Capacity (Veh/hr)	RFC	Throughput (Veh/hr)	End queue (Veh)	Delay (s)	Unsignalised level of service
1	528	272	1432	0.368	525	0.6	3.960	A
2	472	22	2307	0.205	471	0.3	1.960	A
3	306	331	1381	0.221	305	0.3	3.342	A

08:00 - 08:15

Arm	Total Demand (Veh/hr)	Circulating flow (Veh/hr)	Capacity (Veh/hr)	RFC	Throughput (Veh/hr)	End queue (Veh)	Delay (s)	Unsignalised level of service
1	630	325	1399	0.451	629	0.8	4.673	A
2	564	26	2303	0.245	563	0.3	2.068	A
3	365	396	1343	0.272	365	0.4	3.680	A

08:15 - 08:30

Arm	Total Demand (Veh/hr)	Circulating flow (Veh/hr)	Capacity (Veh/hr)	RFC	Throughput (Veh/hr)	End queue (Veh)	Delay (s)	Unsignalised level of service
1	772	398	1353	0.571	770	1.3	6.154	A
2	690	32	2299	0.300	690	0.4	2.237	A
3	447	485	1291	0.346	446	0.5	4.261	A

08:30 - 08:45

Arm	Total Demand (Veh/hr)	Circulating flow (Veh/hr)	Capacity (Veh/hr)	RFC	Throughput (Veh/hr)	End queue (Veh)	Delay (s)	Unsignalised level of service
1	772	399	1352	0.571	772	1.3	6.199	A
2	690	32	2299	0.300	690	0.4	2.237	A
3	447	486	1291	0.346	447	0.5	4.267	A

08:45 - 09:00

Arm	Total Demand (Veh/hr)	Circulating flow (Veh/hr)	Capacity (Veh/hr)	RFC	Throughput (Veh/hr)	End queue (Veh)	Delay (s)	Unsignalised level of service
1	630	326	1398	0.451	632	0.8	4.713	A
2	564	26	2303	0.245	564	0.3	2.071	A
3	365	397	1342	0.272	366	0.4	3.686	A

09:00 - 09:15

Arm	Total Demand (Veh/hr)	Circulating flow (Veh/hr)	Capacity (Veh/hr)	RFC	Throughput (Veh/hr)	End queue (Veh)	Delay (s)	Unsignalised level of service
1	528	273	1432	0.369	529	0.6	3.992	A
2	472	22	2307	0.205	472	0.3	1.962	A
3	306	332	1380	0.221	306	0.3	3.354	A

Queue Variation Results for each time segment**07:45 - 08:00**

Arm	Mean (Veh)	Q05 (Veh)	Q50 (Veh)	Q90 (Veh)	Q95 (Veh)	Percentile message	Marker message	Probability of reaching or exceeding marker	Probability of exactly reaching marker
1	0.58	0.55	1.00	1.40	1.45			N/A	N/A
2	0.26	0.00	0.00	0.26	0.26			N/A	N/A
3	0.28	0.00	0.00	0.28	0.28			N/A	N/A

08:00 - 08:15

Arm	Mean (Veh)	Q05 (Veh)	Q50 (Veh)	Q90 (Veh)	Q95 (Veh)	Percentile message	Marker message	Probability of reaching or exceeding marker	Probability of exactly reaching marker
1	0.81	0.09	0.84	1.46	1.46			N/A	N/A
2	0.32	0.00	0.00	0.32	0.32			N/A	N/A
3	0.37	0.00	0.00	0.37	0.37			N/A	N/A

08:15 - 08:30

Arm	Mean (Veh)	Q05 (Veh)	Q50 (Veh)	Q90 (Veh)	Q95 (Veh)	Percentile message	Marker message	Probability of reaching or exceeding marker	Probability of exactly reaching marker
1	1.31	0.03	0.26	1.31	1.31			N/A	N/A
2	0.43	0.03	0.25	0.45	0.48			N/A	N/A
3	0.53	0.03	0.25	0.53	0.53			N/A	N/A

08:30 - 08:45

Arm	Mean (Veh)	Q05 (Veh)	Q50 (Veh)	Q90 (Veh)	Q95 (Veh)	Percentile message	Marker message	Probability of reaching or exceeding marker	Probability of exactly reaching marker
1	1.32	0.03	0.27	1.32	1.45			N/A	N/A
2	0.43	0.03	0.33	1.36	1.59			N/A	N/A
3	0.53	0.03	0.30	1.38	2.45			N/A	N/A

08:45 - 09:00

Arm	Mean (Veh)	Q05 (Veh)	Q50 (Veh)	Q90 (Veh)	Q95 (Veh)	Percentile message	Marker message	Probability of reaching or exceeding marker	Probability of exactly reaching marker
1	0.83	0.19	0.94	1.42	1.48			N/A	N/A
2	0.32	0.00	0.00	0.32	0.32			N/A	N/A
3	0.38	0.00	0.00	0.38	0.38			N/A	N/A

09:00 - 09:15

Arm	Mean (Veh)	Q05 (Veh)	Q50 (Veh)	Q90 (Veh)	Q95 (Veh)	Percentile message	Marker message	Probability of reaching or exceeding marker	Probability of exactly reaching marker
1	0.59	0.06	0.62	1.33	1.42			N/A	N/A
2	0.26	0.00	0.00	0.26	0.26			N/A	N/A
3	0.29	0.00	0.00	0.29	0.29			N/A	N/A

2032 Do Something (FULL), PM

Data Errors and Warnings

Severity	Area	Item	Description
Warning	Vehicle Mix		HV% is zero for all movements / time segments. Vehicle Mix matrix should be completed whether working in PCUs or Vehs. If HV% at the junction is genuinely zero, please ignore this warning.
Warning	Queue variations	Analysis Options	Queue percentiles may be unreliable if the mean queue in any time segment is very low or very high.

Junction Network

Junctions

Junction	Name	Junction type	Use circulating lanes	Arm order	Junction Delay (s)	Junction LOS
1	untitled	Standard Roundabout		1, 2, 3	3.39	A

Junction Network Options

Driving side	Lighting
Left	Normal/unknown

Traffic Demand

Demand Set Details

ID	Scenario name	Time Period name	Traffic profile type	Start time (HH:mm)	Finish time (HH:mm)	Time segment length (min)
D8	2032 Do Something (FULL)	PM	ONE HOUR	16:45	18:15	15

Vehicle mix source	PCU Factor for a HV (PCU)
HV Percentages	2.00

Demand overview (Traffic)

Arm	Linked arm	Use O-D data	Average Demand (Veh/hr)	Scaling Factor (%)
1		✓	576	100.000
2		✓	861	100.000
3		✓	229	100.000

Origin-Destination Data

Demand (Veh/hr)

		To		
		1	2	3
From	1	0	541	35
	2	539	0	322
	3	25	204	0

Vehicle Mix

Heavy Vehicle Percentages

		To		
		1	2	3
From	1	0	0	0
	2	0	0	0
	3	0	0	0

Results

Results Summary for whole modelled period

Arm	Max RFC	Max Delay (s)	Max Queue (Veh)	Max 95th percentile Queue (Veh)	Max LOS
1	0.43	4.35	0.8	2.4	A
2	0.41	2.67	0.7	2.5	A
3	0.21	3.69	0.3	1.0	A

Main Results for each time segment

16:45 - 17:00

Arm	Total Demand (Veh/hr)	Circulating flow (Veh/hr)	Capacity (Veh/hr)	RFC	Throughput (Veh/hr)	End queue (Veh)	Delay (s)	Unsignalised level of service
1	434	153	1507	0.288	432	0.4	3.345	A
2	648	26	2303	0.281	647	0.4	2.171	A
3	172	405	1338	0.129	172	0.1	3.086	A

17:00 - 17:15

Arm	Total Demand (Veh/hr)	Circulating flow (Veh/hr)	Capacity (Veh/hr)	RFC	Throughput (Veh/hr)	End queue (Veh)	Delay (s)	Unsignalised level of service
1	518	183	1488	0.348	517	0.5	3.706	A
2	774	31	2299	0.337	774	0.5	2.359	A
3	206	484	1291	0.159	206	0.2	3.315	A

17:15 - 17:30

Arm	Total Demand (Veh/hr)	Circulating flow (Veh/hr)	Capacity (Veh/hr)	RFC	Throughput (Veh/hr)	End queue (Veh)	Delay (s)	Unsignalised level of service
1	634	224	1462	0.434	633	0.8	4.339	A
2	948	38	2294	0.413	947	0.7	2.672	A
3	252	593	1228	0.205	252	0.3	3.689	A

17:30 - 17:45

Arm	Total Demand (Veh/hr)	Circulating flow (Veh/hr)	Capacity (Veh/hr)	RFC	Throughput (Veh/hr)	End queue (Veh)	Delay (s)	Unsignalised level of service
1	634	225	1462	0.434	634	0.8	4.348	A
2	948	39	2294	0.413	948	0.7	2.674	A
3	252	593	1227	0.205	252	0.3	3.690	A

17:45 - 18:00

Arm	Total Demand (Veh/hr)	Circulating flow (Veh/hr)	Capacity (Veh/hr)	RFC	Throughput (Veh/hr)	End queue (Veh)	Delay (s)	Unsignalised level of service
1	518	184	1488	0.348	519	0.5	3.717	A
2	774	32	2299	0.337	775	0.5	2.362	A
3	206	485	1291	0.159	206	0.2	3.321	A

18:00 - 18:15

Arm	Total Demand (Veh/hr)	Circulating flow (Veh/hr)	Capacity (Veh/hr)	RFC	Throughput (Veh/hr)	End queue (Veh)	Delay (s)	Unsignalised level of service
1	434	154	1507	0.288	434	0.4	3.357	A
2	648	26	2303	0.281	649	0.4	2.176	A
3	172	406	1337	0.129	173	0.1	3.093	A

Queue Variation Results for each time segment**16:45 - 17:00**

Arm	Mean (Veh)	Q05 (Veh)	Q50 (Veh)	Q90 (Veh)	Q95 (Veh)	Percentile message	Marker message	Probability of reaching or exceeding marker	Probability of exactly reaching marker
1	0.40	0.00	0.00	0.40	0.40			N/A	N/A
2	0.39	0.00	0.00	0.39	0.39			N/A	N/A
3	0.15	0.00	0.00	0.15	0.15			N/A	N/A

17:00 - 17:15

Arm	Mean (Veh)	Q05 (Veh)	Q50 (Veh)	Q90 (Veh)	Q95 (Veh)	Percentile message	Marker message	Probability of reaching or exceeding marker	Probability of exactly reaching marker
1	0.53	0.53	1.00	1.40	1.45			N/A	N/A
2	0.51	0.51	1.00	1.40	1.45			N/A	N/A
3	0.19	0.00	0.00	0.19	0.19			N/A	N/A

17:15 - 17:30

Arm	Mean (Veh)	Q05 (Veh)	Q50 (Veh)	Q90 (Veh)	Q95 (Veh)	Percentile message	Marker message	Probability of reaching or exceeding marker	Probability of exactly reaching marker
1	0.76	0.03	0.25	0.76	0.76			N/A	N/A
2	0.70	0.03	0.25	0.70	0.70			N/A	N/A
3	0.26	0.03	0.25	0.46	0.48			N/A	N/A

17:30 - 17:45

Arm	Mean (Veh)	Q05 (Veh)	Q50 (Veh)	Q90 (Veh)	Q95 (Veh)	Percentile message	Marker message	Probability of reaching or exceeding marker	Probability of exactly reaching marker
1	0.76	0.03	0.28	0.76	2.38			N/A	N/A
2	0.70	0.03	0.28	0.70	2.47			N/A	N/A
3	0.26	0.03	0.28	0.55	1.02			N/A	N/A

17:45 - 18:00

Arm	Mean (Veh)	Q05 (Veh)	Q50 (Veh)	Q90 (Veh)	Q95 (Veh)	Percentile message	Marker message	Probability of reaching or exceeding marker	Probability of exactly reaching marker
1	0.54	0.54	1.00	1.40	1.45			N/A	N/A
2	0.51	0.51	1.00	1.40	1.45			N/A	N/A
3	0.19	0.00	0.00	0.19	0.19			N/A	N/A

18:00 - 18:15

Arm	Mean (Veh)	Q05 (Veh)	Q50 (Veh)	Q90 (Veh)	Q95 (Veh)	Percentile message	Marker message	Probability of reaching or exceeding marker	Probability of exactly reaching marker
1	0.41	0.00	0.00	0.41	0.41			N/A	N/A
2	0.39	0.00	0.00	0.39	0.39			N/A	N/A
3	0.15	0.00	0.00	0.15	0.15			N/A	N/A

Junctions 9

PICADY 9 - Priority Intersection Module

Version: 9.5.1.7462
© Copyright TRL Limited, 2019

For sales and distribution information, program advice and maintenance, contact TRL:
+44 (0)1344 379777 software@trl.co.uk www.trlsoftware.co.uk

The users of this computer program for the solution of an engineering problem are in no way relieved of their responsibility for the correctness of the solution

Filename: 1901 230120 Poplars Avenue Central.j9
Path: C:\Users\Charlie\Highgate Transportation\HTp - 1901 - Peel Hall\Modelling\Site Access Junctions\CJ\Option A\Poplars Ave C\VEH 230120
Report generation date: 23/01/2020 12:21:52

Summary of junction performance

	AM				PM			
	Set ID	Queue (Veh)	Delay (s)	RFC	Set ID	Queue (Veh)	Delay (s)	RFC
2022 Do Something								
Stream B-C	D1	0.1	5.16	0.06	D2	0.1	5.33	0.07
Stream B-A		0.0	7.29	0.03		0.1	7.53	0.06
Stream C-B		0.0	5.12	0.03		0.1	5.33	0.07
2022 Do Something (FULL)								
Stream B-C	D3	0.2	6.04	0.14	D4	0.2	6.01	0.14
Stream B-A		0.1	8.54	0.07		0.1	9.17	0.11
Stream C-B		0.1	5.64	0.07		0.2	6.30	0.18
2027 Do Something								
Stream B-C	D5	0.2	6.29	0.17	D6	0.5	8.28	0.34
Stream B-A		0.1	9.38	0.08		0.3	13.20	0.24
Stream C-B		0.2	6.41	0.17		0.6	8.32	0.37
2032 Do Something (FULL)								
Stream B-C	D7	0.2	6.41	0.15	D8	0.2	6.42	0.15
Stream B-A		0.1	9.67	0.08		0.2	10.73	0.13
Stream C-B		0.1	5.96	0.08		0.2	6.75	0.20

There are warnings associated with one or more model runs - see the 'Data Errors and Warnings' tables for each Analysis or Demand Set.

Values shown are the highest values encountered over all time segments. Delay is the maximum value of average delay per arriving vehicle.

File summary

File Description

Title	(untitled)
Location	
Site number	
Date	02/03/2016
Version	
Status	(new file)
Identifier	
Client	
Jobnumber	
Enumerator	DESKTOP-MD9GBJC\Fiona
Description	

Units

Distance units	Speed units	Traffic units input	Traffic units results	Flow units	Average delay units	Total delay units	Rate of delay units
m	kph	Veh	Veh	perHour	s	-Min	perMin

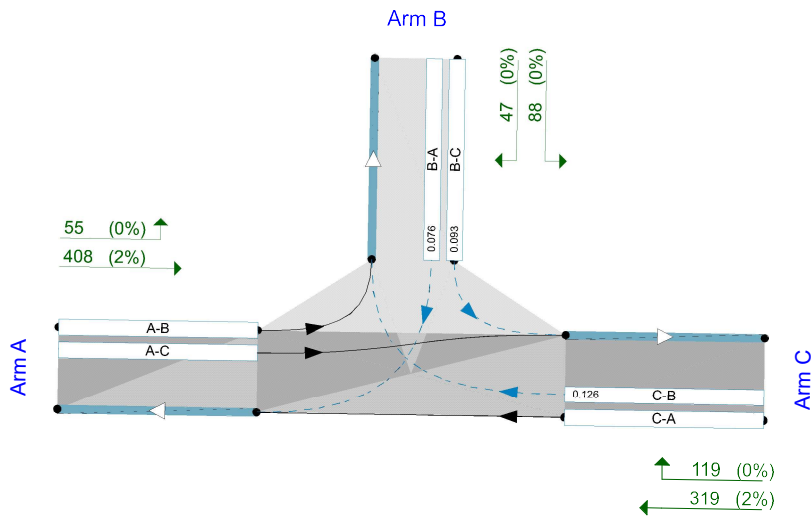

Flows show original traffic demand (Veh/hrs).
Streams (downstream ends) show RFC (s)

The junction diagram reflects the last run of Junctions.

Analysis Options

Calculate Queue Percentiles	Calculate residual capacity	RFC Threshold	Average Delay threshold (s)	Queue threshold (PCU)
✓		0.85	36.00	20.00

Demand Set Summary

ID	Scenario name	Time Period name	Traffic profile type	Start time (HH:mm)	Finish time (HH:mm)	Time segment length (min)
D1	2022 Do Something	AM	ONE HOUR	07:45	09:15	15
D2	2022 Do Something	PM	ONE HOUR	16:45	18:15	15
D3	2022 Do Something (FULL)	AM	ONE HOUR	07:45	09:15	15
D4	2022 Do Something (FULL)	PM	ONE HOUR	16:45	18:15	15
D5	2027 Do Something	AM	ONE HOUR	07:45	09:15	15
D6	2027 Do Something	PM	ONE HOUR	16:45	18:15	15
D7	2032 Do Something (FULL)	AM	ONE HOUR	07:45	09:15	15
D8	2032 Do Something (FULL)	PM	ONE HOUR	16:45	18:15	15

Analysis Set Details

ID	Network flow scaling factor (%)
A1	100.000

2022 Do Something, AM

Data Errors and Warnings

Severity	Area	Item	Description
Warning	Queue variations	Analysis Options	Queue percentiles may be unreliable if the mean queue in any time segment is very low or very high.

Junction Network

Junctions

Junction	Name	Junction type	Major road direction	Use circulating lanes	Junction Delay (s)	Junction LOS
1107A	Poplars Ave central	T-Junction	Two-way		0.78	A

Junction Network Options

Driving side	Lighting
Left	Normal/unknown

Arms

Arms

Arm	Name	Description	Arm type
A	Poplars Ave	WEST	Major
B	Site		Minor
C	Poplars Ave	EAST	Major

Major Arm Geometry

Arm	Width of carriageway (m)	Has kerbed central reserve	Has right turn bay	Width for right turn (m)	Visibility for right turn (m)	Blocks?	Blocking queue (PCU)
C	7.25		✓	3.50	250.0		-

Geometries for Arm C are measured opposite Arm B. Geometries for Arm A (if relevant) are measured opposite Arm D.

Minor Arm Geometry

Arm	Minor arm type	Width at give-way (m)	Width at 5m (m)	Width at 10m (m)	Width at 15m (m)	Width at 20m (m)	Estimate flare length	Flare length (PCU)	Visibility to left (m)	Visibility to right (m)
B	One lane plus flare	10.00	6.50	3.80	3.60	3.60	✓	1.00	65	200

Slope / Intercept / Capacity

Priority Intersection Slopes and Intercepts

Stream	Intercept (Veh/hr)	Slope for A-B	Slope for A-C	Slope for C-A	Slope for C-B
B-A	617	0.106	0.268	0.169	0.383
B-C	839	0.122	0.307	-	-
C-B	820	0.301	0.301	-	-

The slopes and intercepts shown above do NOT include any corrections or adjustments.

Streams may be combined, in which case capacity will be adjusted.

Values are shown for the first time segment only; they may differ for subsequent time segments.

Traffic Demand

Demand Set Details

ID	Scenario name	Time Period name	Traffic profile type	Start time (HH:mm)	Finish time (HH:mm)	Time segment length (min)
D1	2022 Do Something	AM	ONE HOUR	07:45	09:15	15

Vehicle mix source	PCU Factor for a HV (PCU)
HV Percentages	2.00

Demand overview (Traffic)

Arm	Linked arm	Use O-D data	Average Demand (Veh/hr)	Scaling Factor (%)
A		✓	291	100.000
B		✓	49	100.000
C		✓	114	100.000

Origin-Destination Data

Demand (Veh/hr)

		To		
		A	B	C
From	A	0	25	266
	B	12	0	37
	C	97	17	0

Vehicle Mix

Heavy Vehicle Percentages

		To		
		A	B	C
From	A	0	0	2
	B	0	0	0
	C	8	0	0

Results

Results Summary for whole modelled period

Stream	Max RFC	Max Delay (s)	Max Queue (Veh)	Max 95th percentile Queue (Veh)	Max LOS
B-C	0.06	5.16	0.1	0.5	A
B-A	0.03	7.29	0.0	0.5	A
C-A					
C-B	0.03	5.12	0.0	0.5	A
A-B					
A-C					

Main Results for each time segment

07:45 - 08:00

Stream	Total Demand (Veh/hr)	Capacity (Veh/hr)	RFC	Throughput (Veh/hr)	End queue (Veh)	Delay (s)	Unsignalised level of service
B-C	28	770	0.036	28	0.0	4.846	A
B-A	9	542	0.017	9	0.0	6.759	A
C-A	73			73			
C-B	13	753	0.017	13	0.0	4.860	A
A-B	19			19			
A-C	200			200			

08:00 - 08:15

Stream	Total Demand (Veh/hr)	Capacity (Veh/hr)	RFC	Throughput (Veh/hr)	End queue (Veh)	Delay (s)	Unsignalised level of service
B-C	33	757	0.044	33	0.0	4.974	A
B-A	11	527	0.020	11	0.0	6.973	A
C-A	87			87			
C-B	15	740	0.021	15	0.0	4.964	A
A-B	22			22			
A-C	239			239			

08:15 - 08:30

Stream	Total Demand (Veh/hr)	Capacity (Veh/hr)	RFC	Throughput (Veh/hr)	End queue (Veh)	Delay (s)	Unsignalised level of service
B-C	41	738	0.055	41	0.1	5.158	A
B-A	13	507	0.026	13	0.0	7.292	A
C-A	107			107			
C-B	19	722	0.026	19	0.0	5.115	A
A-B	28			28			
A-C	293			293			

08:30 - 08:45

Stream	Total Demand (Veh/hr)	Capacity (Veh/hr)	RFC	Throughput (Veh/hr)	End queue (Veh)	Delay (s)	Unsignalised level of service
B-C	41	738	0.055	41	0.1	5.158	A
B-A	13	507	0.026	13	0.0	7.292	A
C-A	107			107			
C-B	19	722	0.026	19	0.0	5.115	A
A-B	28			28			
A-C	293			293			

08:45 - 09:00

Stream	Total Demand (Veh/hr)	Capacity (Veh/hr)	RFC	Throughput (Veh/hr)	End queue (Veh)	Delay (s)	Unsignalised level of service
B-C	33	757	0.044	33	0.0	4.977	A
B-A	11	527	0.020	11	0.0	6.973	A
C-A	87			87			
C-B	15	740	0.021	15	0.0	4.966	A
A-B	22			22			
A-C	239			239			

09:00 - 09:15

Stream	Total Demand (Veh/hr)	Capacity (Veh/hr)	RFC	Throughput (Veh/hr)	End queue (Veh)	Delay (s)	Unsignalised level of service
B-C	28	770	0.036	28	0.0	4.851	A
B-A	9	542	0.017	9	0.0	6.761	A
C-A	73			73			
C-B	13	753	0.017	13	0.0	4.860	A
A-B	19			19			
A-C	200			200			

Queue Variation Results for each time segment

07:45 - 08:00

Stream	Mean (Veh)	Q05 (Veh)	Q50 (Veh)	Q90 (Veh)	Q95 (Veh)	Percentile message	Marker message	Probability of reaching or exceeding marker	Probability of exactly reaching marker
B-C	0.04	0.00	0.00	0.04	0.04			N/A	N/A
B-A	0.02	0.00	0.00	0.02	0.02			N/A	N/A
C-B	0.02	0.00	0.00	0.02	0.02			N/A	N/A

08:00 - 08:15

Stream	Mean (Veh)	Q05 (Veh)	Q50 (Veh)	Q90 (Veh)	Q95 (Veh)	Percentile message	Marker message	Probability of reaching or exceeding marker	Probability of exactly reaching marker
B-C	0.05	0.03	0.25	0.45	0.48			N/A	N/A
B-A	0.02	0.02	0.25	0.45	0.48			N/A	N/A
C-B	0.02	0.02	0.25	0.45	0.48			N/A	N/A

08:15 - 08:30

Stream	Mean (Veh)	Q05 (Veh)	Q50 (Veh)	Q90 (Veh)	Q95 (Veh)	Percentile message	Marker message	Probability of reaching or exceeding marker	Probability of exactly reaching marker
B-C	0.06	0.03	0.26	0.46	0.49			N/A	N/A
B-A	0.03	0.00	0.00	0.03	0.03			N/A	N/A
C-B	0.03	0.00	0.00	0.03	0.03			N/A	N/A

08:30 - 08:45

Stream	Mean (Veh)	Q05 (Veh)	Q50 (Veh)	Q90 (Veh)	Q95 (Veh)	Percentile message	Marker message	Probability of reaching or exceeding marker	Probability of exactly reaching marker
B-C	0.06	0.00	0.00	0.06	0.06			N/A	N/A
B-A	0.03	0.00	0.00	0.03	0.03			N/A	N/A
C-B	0.03	0.00	0.00	0.03	0.03			N/A	N/A

08:45 - 09:00

Stream	Mean (Veh)	Q05 (Veh)	Q50 (Veh)	Q90 (Veh)	Q95 (Veh)	Percentile message	Marker message	Probability of reaching or exceeding marker	Probability of exactly reaching marker
B-C	0.05	0.00	0.00	0.05	0.05			N/A	N/A
B-A	0.02	0.00	0.00	0.02	0.02			N/A	N/A
C-B	0.02	0.00	0.00	0.02	0.02			N/A	N/A

09:00 - 09:15

Stream	Mean (Veh)	Q05 (Veh)	Q50 (Veh)	Q90 (Veh)	Q95 (Veh)	Percentile message	Marker message	Probability of reaching or exceeding marker	Probability of exactly reaching marker
B-C	0.04	0.00	0.00	0.04	0.04			N/A	N/A
B-A	0.02	0.00	0.00	0.02	0.02			N/A	N/A
C-B	0.02	0.00	0.00	0.02	0.02			N/A	N/A

2022 Do Something, PM

Data Errors and Warnings

Severity	Area	Item	Description
Warning	Queue variations	Analysis Options	Queue percentiles may be unreliable if the mean queue in any time segment is very low or very high.

Junction Network

Junctions

Junction	Name	Junction type	Major road direction	Use circulating lanes	Junction Delay (s)	Junction LOS
1107A	Poplars Ave central	T-Junction	Two-way		1.23	A

Junction Network Options

Driving side	Lighting
Left	Normal/unknown

Traffic Demand

Demand Set Details

ID	Scenario name	Time Period name	Traffic profile type	Start time (HH:mm)	Finish time (HH:mm)	Time segment length (min)
D2	2022 Do Something	PM	ONE HOUR	16:45	18:15	15

Vehicle mix source	PCU Factor for a HV (PCU)
HV Percentages	2.00

Demand overview (Traffic)

Arm	Linked arm	Use O-D data	Average Demand (Veh/hr)	Scaling Factor (%)
A		✓	280	100.000
B		✓	75	100.000
C		✓	198	100.000

Origin-Destination Data

Demand (Veh/hr)

		To		
		A	B	C
From	A	0	39	241
	B	27	0	48
	C	153	45	0

Vehicle Mix

Heavy Vehicle Percentages

		To		
		A	B	C
From	A	0	0	3
	B	0	0	0
	C	4	0	0

Results

Results Summary for whole modelled period

Stream	Max RFC	Max Delay (s)	Max Queue (Veh)	Max 95th percentile Queue (Veh)	Max LOS
B-C	0.07	5.33	0.1	0.5	A
B-A	0.06	7.53	0.1	0.5	A
C-A					
C-B	0.07	5.33	0.1	0.5	A
A-B					
A-C					

Main Results for each time segment

16:45 - 17:00

Stream	Total Demand (Veh/hr)	Capacity (Veh/hr)	RFC	Throughput (Veh/hr)	End queue (Veh)	Delay (s)	Unsignalised level of service
B-C	36	760	0.048	36	0.0	4.970	A
B-A	20	549	0.037	20	0.0	6.801	A
C-A	115			115			
C-B	34	755	0.045	34	0.0	4.986	A
A-B	29			29			
A-C	181			181			

17:00 - 17:15

Stream	Total Demand (Veh/hr)	Capacity (Veh/hr)	RFC	Throughput (Veh/hr)	End queue (Veh)	Delay (s)	Unsignalised level of service
B-C	43	747	0.058	43	0.1	5.116	A
B-A	24	532	0.046	24	0.0	7.091	A
C-A	138			138			
C-B	40	743	0.054	40	0.1	5.125	A
A-B	35			35			
A-C	217			217			

17:15 - 17:30

Stream	Total Demand (Veh/hr)	Capacity (Veh/hr)	RFC	Throughput (Veh/hr)	End queue (Veh)	Delay (s)	Unsignalised level of service
B-C	53	728	0.073	53	0.1	5.329	A
B-A	30	508	0.059	30	0.1	7.530	A
C-A	168			168			
C-B	50	725	0.068	49	0.1	5.326	A
A-B	43			43			
A-C	265			265			

17:30 - 17:45

Stream	Total Demand (Veh/hr)	Capacity (Veh/hr)	RFC	Throughput (Veh/hr)	End queue (Veh)	Delay (s)	Unsignalised level of service
B-C	53	728	0.073	53	0.1	5.330	A
B-A	30	508	0.059	30	0.1	7.530	A
C-A	168			168			
C-B	50	725	0.068	50	0.1	5.326	A
A-B	43			43			
A-C	265			265			

17:45 - 18:00

Stream	Total Demand (Veh/hr)	Capacity (Veh/hr)	RFC	Throughput (Veh/hr)	End queue (Veh)	Delay (s)	Unsignalised level of service
B-C	43	747	0.058	43	0.1	5.120	A
B-A	24	532	0.046	24	0.0	7.092	A
C-A	138			138			
C-B	40	743	0.054	41	0.1	5.125	A
A-B	35			35			
A-C	217			217			

18:00 - 18:15

Stream	Total Demand (Veh/hr)	Capacity (Veh/hr)	RFC	Throughput (Veh/hr)	End queue (Veh)	Delay (s)	Unsignalised level of service
B-C	36	760	0.048	36	0.1	4.974	A
B-A	20	549	0.037	20	0.0	6.807	A
C-A	115			115			
C-B	34	755	0.045	34	0.0	4.989	A
A-B	29			29			
A-C	181			181			

Queue Variation Results for each time segment

16:45 - 17:00

Stream	Mean (Veh)	Q05 (Veh)	Q50 (Veh)	Q90 (Veh)	Q95 (Veh)	Percentile message	Marker message	Probability of reaching or exceeding marker	Probability of exactly reaching marker
B-C	0.05	0.00	0.00	0.05	0.05			N/A	N/A
B-A	0.04	0.00	0.00	0.04	0.04			N/A	N/A
C-B	0.05	0.00	0.00	0.05	0.05			N/A	N/A

17:00 - 17:15

Stream	Mean (Veh)	Q05 (Veh)	Q50 (Veh)	Q90 (Veh)	Q95 (Veh)	Percentile message	Marker message	Probability of reaching or exceeding marker	Probability of exactly reaching marker
B-C	0.06	0.03	0.25	0.45	0.48			N/A	N/A
B-A	0.05	0.03	0.25	0.45	0.48			N/A	N/A
C-B	0.06	0.03	0.25	0.45	0.48			N/A	N/A

17:15 - 17:30

Stream	Mean (Veh)	Q05 (Veh)	Q50 (Veh)	Q90 (Veh)	Q95 (Veh)	Percentile message	Marker message	Probability of reaching or exceeding marker	Probability of exactly reaching marker
B-C	0.08	0.03	0.26	0.47	0.49			N/A	N/A
B-A	0.06	0.03	0.26	0.47	0.49			N/A	N/A
C-B	0.07	0.03	0.26	0.47	0.49			N/A	N/A

17:30 - 17:45

Stream	Mean (Veh)	Q05 (Veh)	Q50 (Veh)	Q90 (Veh)	Q95 (Veh)	Percentile message	Marker message	Probability of reaching or exceeding marker	Probability of exactly reaching marker
B-C	0.08	0.00	0.00	0.08	0.08			N/A	N/A
B-A	0.06	0.00	0.00	0.06	0.06			N/A	N/A
C-B	0.07	0.00	0.00	0.07	0.07			N/A	N/A

17:45 - 18:00

Stream	Mean (Veh)	Q05 (Veh)	Q50 (Veh)	Q90 (Veh)	Q95 (Veh)	Percentile message	Marker message	Probability of reaching or exceeding marker	Probability of exactly reaching marker
B-C	0.06	0.00	0.00	0.06	0.06			N/A	N/A
B-A	0.05	0.00	0.00	0.05	0.05			N/A	N/A
C-B	0.06	0.00	0.00	0.06	0.06			N/A	N/A

18:00 - 18:15

Stream	Mean (Veh)	Q05 (Veh)	Q50 (Veh)	Q90 (Veh)	Q95 (Veh)	Percentile message	Marker message	Probability of reaching or exceeding marker	Probability of exactly reaching marker
B-C	0.05	0.00	0.00	0.05	0.05			N/A	N/A
B-A	0.04	0.00	0.00	0.04	0.04			N/A	N/A
C-B	0.05	0.00	0.00	0.05	0.05			N/A	N/A

2022 Do Something (FULL), AM

Data Errors and Warnings

Severity	Area	Item	Description
Warning	Queue variations	Analysis Options	Queue percentiles may be unreliable if the mean queue in any time segment is very low or very high.

Junction Network

Junctions

Junction	Name	Junction type	Major road direction	Use circulating lanes	Junction Delay (s)	Junction LOS
1107A	Poplars Ave central	T-Junction	Two-way		1.42	A

Junction Network Options

Driving side	Lighting
Left	Normal/unknown

Traffic Demand

Demand Set Details

ID	Scenario name	Time Period name	Traffic profile type	Start time (HH:mm)	Finish time (HH:mm)	Time segment length (min)
D3	2022 Do Something (FULL)	AM	ONE HOUR	07:45	09:15	15

Vehicle mix source	PCU Factor for a HV (PCU)
HV Percentages	2.00

Demand overview (Traffic)

Arm	Linked arm	Use O-D data	Average Demand (Veh/hr)	Scaling Factor (%)
A		✓	400	100.000
B		✓	119	100.000
C		✓	191	100.000

Origin-Destination Data

Demand (Veh/hr)

		To		
		A	B	C
From	A	0	33	367
	B	28	0	91
	C	148	43	0

Vehicle Mix

Heavy Vehicle Percentages

		To		
		A	B	C
From	A	0	0	2
	B	0	0	0
	C	5	0	0

Results

Results Summary for whole modelled period

Stream	Max RFC	Max Delay (s)	Max Queue (Veh)	Max 95th percentile Queue (Veh)	Max LOS
B-C	0.14	6.04	0.2	0.5	A
B-A	0.07	8.54	0.1	0.5	A
C-A					
C-B	0.07	5.64	0.1	0.5	A
A-B					
A-C					

Main Results for each time segment

07:45 - 08:00

Stream	Total Demand (Veh/hr)	Capacity (Veh/hr)	RFC	Throughput (Veh/hr)	End queue (Veh)	Delay (s)	Unsignalised level of service
B-C	69	742	0.092	68	0.1	5.339	A
B-A	21	504	0.042	21	0.0	7.446	A
C-A	111			111			
C-B	32	728	0.044	32	0.0	5.170	A
A-B	25			25			
A-C	276			276			

08:00 - 08:15

Stream	Total Demand (Veh/hr)	Capacity (Veh/hr)	RFC	Throughput (Veh/hr)	End queue (Veh)	Delay (s)	Unsignalised level of service
B-C	82	723	0.113	82	0.1	5.617	A
B-A	25	483	0.052	25	0.1	7.868	A
C-A	133			133			
C-B	39	710	0.054	39	0.1	5.358	A
A-B	30			30			
A-C	330			330			

08:15 - 08:30

Stream	Total Demand (Veh/hr)	Capacity (Veh/hr)	RFC	Throughput (Veh/hr)	End queue (Veh)	Delay (s)	Unsignalised level of service
B-C	100	696	0.144	100	0.2	6.041	A
B-A	31	452	0.068	31	0.1	8.536	A
C-A	163			163			
C-B	47	686	0.069	47	0.1	5.639	A
A-B	36			36			
A-C	404			404			

08:30 - 08:45

Stream	Total Demand (Veh/hr)	Capacity (Veh/hr)	RFC	Throughput (Veh/hr)	End queue (Veh)	Delay (s)	Unsignalised level of service
B-C	100	696	0.144	100	0.2	6.044	A
B-A	31	452	0.068	31	0.1	8.538	A
C-A	163			163			
C-B	47	686	0.069	47	0.1	5.639	A
A-B	36			36			
A-C	404			404			

08:45 - 09:00

Stream	Total Demand (Veh/hr)	Capacity (Veh/hr)	RFC	Throughput (Veh/hr)	End queue (Veh)	Delay (s)	Unsignalised level of service
B-C	82	722	0.113	82	0.1	5.623	A
B-A	25	483	0.052	25	0.1	7.872	A
C-A	133			133			
C-B	39	710	0.054	39	0.1	5.362	A
A-B	30			30			
A-C	330			330			

09:00 - 09:15

Stream	Total Demand (Veh/hr)	Capacity (Veh/hr)	RFC	Throughput (Veh/hr)	End queue (Veh)	Delay (s)	Unsignalised level of service
B-C	69	742	0.092	69	0.1	5.348	A
B-A	21	504	0.042	21	0.0	7.451	A
C-A	111			111			
C-B	32	728	0.044	32	0.0	5.175	A
A-B	25			25			
A-C	276			276			

Queue Variation Results for each time segment**07:45 - 08:00**

Stream	Mean (Veh)	Q05 (Veh)	Q50 (Veh)	Q90 (Veh)	Q95 (Veh)	Percentile message	Marker message	Probability of reaching or exceeding marker	Probability of exactly reaching marker
B-C	0.10	0.00	0.00	0.10	0.10			N/A	N/A
B-A	0.04	0.00	0.00	0.04	0.04			N/A	N/A
C-B	0.05	0.00	0.00	0.05	0.05			N/A	N/A

08:00 - 08:15

Stream	Mean (Veh)	Q05 (Veh)	Q50 (Veh)	Q90 (Veh)	Q95 (Veh)	Percentile message	Marker message	Probability of reaching or exceeding marker	Probability of exactly reaching marker
B-C	0.13	0.00	0.00	0.13	0.13			N/A	N/A
B-A	0.05	0.03	0.25	0.45	0.48			N/A	N/A
C-B	0.06	0.03	0.25	0.45	0.48			N/A	N/A

08:15 - 08:30

Stream	Mean (Veh)	Q05 (Veh)	Q50 (Veh)	Q90 (Veh)	Q95 (Veh)	Percentile message	Marker message	Probability of reaching or exceeding marker	Probability of exactly reaching marker
B-C	0.17	0.03	0.26	0.46	0.49			N/A	N/A
B-A	0.07	0.03	0.26	0.47	0.49			N/A	N/A
C-B	0.07	0.03	0.26	0.47	0.49			N/A	N/A

08:30 - 08:45

Stream	Mean (Veh)	Q05 (Veh)	Q50 (Veh)	Q90 (Veh)	Q95 (Veh)	Percentile message	Marker message	Probability of reaching or exceeding marker	Probability of exactly reaching marker
B-C	0.17	0.03	0.25	0.45	0.48			N/A	N/A
B-A	0.07	0.00	0.00	0.07	0.07			N/A	N/A
C-B	0.07	0.00	0.00	0.07	0.07			N/A	N/A

08:45 - 09:00

Stream	Mean (Veh)	Q05 (Veh)	Q50 (Veh)	Q90 (Veh)	Q95 (Veh)	Percentile message	Marker message	Probability of reaching or exceeding marker	Probability of exactly reaching marker
B-C	0.13	0.00	0.00	0.13	0.13			N/A	N/A
B-A	0.06	0.00	0.00	0.06	0.06			N/A	N/A
C-B	0.06	0.00	0.00	0.06	0.06			N/A	N/A

09:00 - 09:15

Stream	Mean (Veh)	Q05 (Veh)	Q50 (Veh)	Q90 (Veh)	Q95 (Veh)	Percentile message	Marker message	Probability of reaching or exceeding marker	Probability of exactly reaching marker
B-C	0.10	0.00	0.00	0.10	0.10			N/A	N/A
B-A	0.04	0.00	0.00	0.04	0.04			N/A	N/A
C-B	0.05	0.00	0.00	0.05	0.05			N/A	N/A

2022 Do Something (FULL), PM

Data Errors and Warnings

Severity	Area	Item	Description
Warning	Queue variations	Analysis Options	Queue percentiles may be unreliable if the mean queue in any time segment is very low or very high.

Junction Network

Junctions

Junction	Name	Junction type	Major road direction	Use circulating lanes	Junction Delay (s)	Junction LOS
1107A	Poplars Ave central	T-Junction	Two-way		2.05	A

Junction Network Options

Driving side	Lighting
Left	Normal/unknown

Traffic Demand

Demand Set Details

ID	Scenario name	Time Period name	Traffic profile type	Start time (HH:mm)	Finish time (HH:mm)	Time segment length (min)
D4	2022 Do Something (FULL)	PM	ONE HOUR	16:45	18:15	15

Vehicle mix source	PCU Factor for a HV (PCU)
HV Percentages	2.00

Demand overview (Traffic)

Arm	Linked arm	Use O-D data	Average Demand (Veh/hr)	Scaling Factor (%)
A		✓	357	100.000
B		✓	135	100.000
C		✓	318	100.000

Origin-Destination Data

Demand (Veh/hr)

		To		
		A	B	C
From	A	0	57	300
	B	44	0	91
	C	201	117	0

Vehicle Mix

Heavy Vehicle Percentages

		To		
		A	B	C
From	A	0	0	2
	B	0	0	0
	C	3	0	0

Results

Results Summary for whole modelled period

Stream	Max RFC	Max Delay (s)	Max Queue (Veh)	Max 95th percentile Queue (Veh)	Max LOS
B-C	0.14	6.01	0.2	0.5	A
B-A	0.11	9.17	0.1	0.5	A
C-A					
C-B	0.18	6.30	0.2	0.9	A
A-B					
A-C					

Main Results for each time segment

16:45 - 17:00

Stream	Total Demand (Veh/hr)	Capacity (Veh/hr)	RFC	Throughput (Veh/hr)	End queue (Veh)	Delay (s)	Unsignalised level of service
B-C	69	743	0.092	68	0.1	5.333	A
B-A	33	502	0.066	33	0.1	7.663	A
C-A	151			151			
C-B	88	738	0.119	88	0.1	5.527	A
A-B	43			43			
A-C	226			226			

17:00 - 17:15

Stream	Total Demand (Veh/hr)	Capacity (Veh/hr)	RFC	Throughput (Veh/hr)	End queue (Veh)	Delay (s)	Unsignalised level of service
B-C	82	725	0.113	82	0.1	5.599	A
B-A	40	477	0.083	39	0.1	8.233	A
C-A	181			181			
C-B	105	722	0.146	105	0.2	5.830	A
A-B	51			51			
A-C	270			270			

17:15 - 17:30

Stream	Total Demand (Veh/hr)	Capacity (Veh/hr)	RFC	Throughput (Veh/hr)	End queue (Veh)	Delay (s)	Unsignalised level of service
B-C	100	699	0.143	100	0.2	6.004	A
B-A	48	441	0.110	48	0.1	9.161	A
C-A	221			221			
C-B	129	700	0.184	129	0.2	6.297	A
A-B	63			63			
A-C	330			330			

17:30 - 17:45

Stream	Total Demand (Veh/hr)	Capacity (Veh/hr)	RFC	Throughput (Veh/hr)	End queue (Veh)	Delay (s)	Unsignalised level of service
B-C	100	699	0.143	100	0.2	6.007	A
B-A	48	441	0.110	48	0.1	9.167	A
C-A	221			221			
C-B	129	700	0.184	129	0.2	6.298	A
A-B	63			63			
A-C	330			330			

17:45 - 18:00

Stream	Total Demand (Veh/hr)	Capacity (Veh/hr)	RFC	Throughput (Veh/hr)	End queue (Veh)	Delay (s)	Unsignalised level of service
B-C	82	725	0.113	82	0.1	5.605	A
B-A	40	477	0.083	40	0.1	8.241	A
C-A	181			181			
C-B	105	722	0.146	105	0.2	5.838	A
A-B	51			51			
A-C	270			270			

18:00 - 18:15

Stream	Total Demand (Veh/hr)	Capacity (Veh/hr)	RFC	Throughput (Veh/hr)	End queue (Veh)	Delay (s)	Unsignalised level of service
B-C	69	742	0.092	69	0.1	5.345	A
B-A	33	502	0.066	33	0.1	7.680	A
C-A	151			151			
C-B	88	738	0.119	88	0.1	5.540	A
A-B	43			43			
A-C	226			226			

Queue Variation Results for each time segment

16:45 - 17:00

Stream	Mean (Veh)	Q05 (Veh)	Q50 (Veh)	Q90 (Veh)	Q95 (Veh)	Percentile message	Marker message	Probability of reaching or exceeding marker	Probability of exactly reaching marker
B-C	0.10	0.00	0.00	0.10	0.10			N/A	N/A
B-A	0.07	0.00	0.00	0.07	0.07			N/A	N/A
C-B	0.13	0.00	0.00	0.13	0.13			N/A	N/A

17:00 - 17:15

Stream	Mean (Veh)	Q05 (Veh)	Q50 (Veh)	Q90 (Veh)	Q95 (Veh)	Percentile message	Marker message	Probability of reaching or exceeding marker	Probability of exactly reaching marker
B-C	0.13	0.00	0.00	0.13	0.13			N/A	N/A
B-A	0.09	0.03	0.25	0.45	0.48			N/A	N/A
C-B	0.17	0.00	0.00	0.17	0.17			N/A	N/A

17:15 - 17:30

Stream	Mean (Veh)	Q05 (Veh)	Q50 (Veh)	Q90 (Veh)	Q95 (Veh)	Percentile message	Marker message	Probability of reaching or exceeding marker	Probability of exactly reaching marker
B-C	0.17	0.03	0.26	0.46	0.49			N/A	N/A
B-A	0.12	0.03	0.26	0.47	0.49			N/A	N/A
C-B	0.22	0.03	0.26	0.46	0.48			N/A	N/A

17:30 - 17:45

Stream	Mean (Veh)	Q05 (Veh)	Q50 (Veh)	Q90 (Veh)	Q95 (Veh)	Percentile message	Marker message	Probability of reaching or exceeding marker	Probability of exactly reaching marker
B-C	0.17	0.03	0.25	0.45	0.48			N/A	N/A
B-A	0.12	0.03	0.25	0.45	0.48			N/A	N/A
C-B	0.22	0.03	0.27	0.49	0.90			N/A	N/A

17:45 - 18:00

Stream	Mean (Veh)	Q05 (Veh)	Q50 (Veh)	Q90 (Veh)	Q95 (Veh)	Percentile message	Marker message	Probability of reaching or exceeding marker	Probability of exactly reaching marker
B-C	0.13	0.00	0.00	0.13	0.13			N/A	N/A
B-A	0.09	0.00	0.00	0.09	0.09			N/A	N/A
C-B	0.17	0.00	0.00	0.17	0.17			N/A	N/A

18:00 - 18:15

Stream	Mean (Veh)	Q05 (Veh)	Q50 (Veh)	Q90 (Veh)	Q95 (Veh)	Percentile message	Marker message	Probability of reaching or exceeding marker	Probability of exactly reaching marker
B-C	0.10	0.00	0.00	0.10	0.10			N/A	N/A
B-A	0.07	0.00	0.00	0.07	0.07			N/A	N/A
C-B	0.14	0.00	0.00	0.14	0.14			N/A	N/A

2027 Do Something, AM

Data Errors and Warnings

Severity	Area	Item	Description
Warning	Queue variations	Analysis Options	Queue percentiles may be unreliable if the mean queue in any time segment is very low or very high.

Junction Network

Junctions

Junction	Name	Junction type	Major road direction	Use circulating lanes	Junction Delay (s)	Junction LOS
1107A	Poplars Ave central	T-Junction	Two-way		1.97	A

Junction Network Options

Driving side	Lighting
Left	Normal/unknown

Traffic Demand

Demand Set Details

ID	Scenario name	Time Period name	Traffic profile type	Start time (HH:mm)	Finish time (HH:mm)	Time segment length (min)
D5	2027 Do Something	AM	ONE HOUR	07:45	09:15	15

Vehicle mix source	PCU Factor for a HV (PCU)
HV Percentages	2.00

Demand overview (Traffic)

Arm	Linked arm	Use O-D data	Average Demand (Veh/hr)	Scaling Factor (%)
A		✓	420	100.000
B		✓	136	100.000
C		✓	262	100.000

Origin-Destination Data

Demand (Veh/hr)

		To		
		A	B	C
From	A	0	39	381
	B	31	0	105
	C	155	107	0

Vehicle Mix

Heavy Vehicle Percentages

		To		
		A	B	C
From	A	0	0	2
	B	0	0	0
	C	5	0	0

Results

Results Summary for whole modelled period

Stream	Max RFC	Max Delay (s)	Max Queue (Veh)	Max 95th percentile Queue (Veh)	Max LOS
B-C	0.17	6.29	0.2	0.5	A
B-A	0.08	9.38	0.1	0.5	A
C-A					
C-B	0.17	6.41	0.2	0.5	A
A-B					
A-C					

Main Results for each time segment

07:45 - 08:00

Stream	Total Demand (Veh/hr)	Capacity (Veh/hr)	RFC	Throughput (Veh/hr)	End queue (Veh)	Delay (s)	Unsignalised level of service
B-C	79	737	0.107	79	0.1	5.463	A
B-A	23	481	0.049	23	0.1	7.864	A
C-A	117			117			
C-B	81	724	0.111	80	0.1	5.590	A
A-B	29			29			
A-C	287			287			

08:00 - 08:15

Stream	Total Demand (Veh/hr)	Capacity (Veh/hr)	RFC	Throughput (Veh/hr)	End queue (Veh)	Delay (s)	Unsignalised level of service
B-C	94	717	0.132	94	0.2	5.782	A
B-A	28	454	0.061	28	0.1	8.439	A
C-A	139			139			
C-B	96	705	0.136	96	0.2	5.911	A
A-B	35			35			
A-C	343			343			

08:15 - 08:30

Stream	Total Demand (Veh/hr)	Capacity (Veh/hr)	RFC	Throughput (Veh/hr)	End queue (Veh)	Delay (s)	Unsignalised level of service
B-C	116	688	0.168	115	0.2	6.287	A
B-A	34	418	0.082	34	0.1	9.378	A
C-A	171			171			
C-B	118	679	0.174	118	0.2	6.412	A
A-B	43			43			
A-C	419			419			

08:30 - 08:45

Stream	Total Demand (Veh/hr)	Capacity (Veh/hr)	RFC	Throughput (Veh/hr)	End queue (Veh)	Delay (s)	Unsignalised level of service
B-C	116	688	0.168	116	0.2	6.290	A
B-A	34	418	0.082	34	0.1	9.384	A
C-A	171			171			
C-B	118	679	0.174	118	0.2	6.415	A
A-B	43			43			
A-C	419			419			

08:45 - 09:00

Stream	Total Demand (Veh/hr)	Capacity (Veh/hr)	RFC	Throughput (Veh/hr)	End queue (Veh)	Delay (s)	Unsignalised level of service
B-C	94	717	0.132	95	0.2	5.789	A
B-A	28	454	0.061	28	0.1	8.447	A
C-A	139			139			
C-B	96	705	0.136	96	0.2	5.919	A
A-B	35			35			
A-C	343			343			

09:00 - 09:15

Stream	Total Demand (Veh/hr)	Capacity (Veh/hr)	RFC	Throughput (Veh/hr)	End queue (Veh)	Delay (s)	Unsignalised level of service
B-C	79	737	0.107	79	0.1	5.475	A
B-A	23	480	0.049	23	0.1	7.878	A
C-A	117			117			
C-B	81	724	0.111	81	0.1	5.599	A
A-B	29			29			
A-C	287			287			

Queue Variation Results for each time segment

07:45 - 08:00

Stream	Mean (Veh)	Q05 (Veh)	Q50 (Veh)	Q90 (Veh)	Q95 (Veh)	Percentile message	Marker message	Probability of reaching or exceeding marker	Probability of exactly reaching marker
B-C	0.12	0.00	0.00	0.12	0.12			N/A	N/A
B-A	0.05	0.00	0.00	0.05	0.05			N/A	N/A
C-B	0.12	0.00	0.00	0.12	0.12			N/A	N/A

08:00 - 08:15

Stream	Mean (Veh)	Q05 (Veh)	Q50 (Veh)	Q90 (Veh)	Q95 (Veh)	Percentile message	Marker message	Probability of reaching or exceeding marker	Probability of exactly reaching marker
B-C	0.15	0.00	0.00	0.15	0.15			N/A	N/A
B-A	0.06	0.03	0.25	0.45	0.48			N/A	N/A
C-B	0.16	0.00	0.00	0.16	0.16			N/A	N/A

08:15 - 08:30

Stream	Mean (Veh)	Q05 (Veh)	Q50 (Veh)	Q90 (Veh)	Q95 (Veh)	Percentile message	Marker message	Probability of reaching or exceeding marker	Probability of exactly reaching marker
B-C	0.20	0.03	0.26	0.46	0.49			N/A	N/A
B-A	0.09	0.03	0.26	0.47	0.49			N/A	N/A
C-B	0.21	0.03	0.26	0.46	0.49			N/A	N/A

08:30 - 08:45

Stream	Mean (Veh)	Q05 (Veh)	Q50 (Veh)	Q90 (Veh)	Q95 (Veh)	Percentile message	Marker message	Probability of reaching or exceeding marker	Probability of exactly reaching marker
B-C	0.20	0.03	0.26	0.46	0.49			N/A	N/A
B-A	0.09	0.03	0.25	0.45	0.48			N/A	N/A
C-B	0.21	0.03	0.26	0.47	0.50			N/A	N/A

08:45 - 09:00

Stream	Mean (Veh)	Q05 (Veh)	Q50 (Veh)	Q90 (Veh)	Q95 (Veh)	Percentile message	Marker message	Probability of reaching or exceeding marker	Probability of exactly reaching marker
B-C	0.15	0.00	0.00	0.15	0.15			N/A	N/A
B-A	0.07	0.00	0.00	0.07	0.07			N/A	N/A
C-B	0.16	0.00	0.00	0.16	0.16			N/A	N/A

09:00 - 09:15

Stream	Mean (Veh)	Q05 (Veh)	Q50 (Veh)	Q90 (Veh)	Q95 (Veh)	Percentile message	Marker message	Probability of reaching or exceeding marker	Probability of exactly reaching marker
B-C	0.12	0.00	0.00	0.12	0.12			N/A	N/A
B-A	0.05	0.00	0.00	0.05	0.05			N/A	N/A
C-B	0.13	0.00	0.00	0.13	0.13			N/A	N/A

2027 Do Something, PM

Data Errors and Warnings

Severity	Area	Item	Description
Warning	Queue variations	Analysis Options	Queue percentiles may be unreliable if the mean queue in any time segment is very low or very high.

Junction Network

Junctions

Junction	Name	Junction type	Major road direction	Use circulating lanes	Junction Delay (s)	Junction LOS
1107A	Poplars Ave central	T-Junction	Two-way		4.00	A

Junction Network Options

Driving side	Lighting
Left	Normal/unknown

Traffic Demand

Demand Set Details

ID	Scenario name	Time Period name	Traffic profile type	Start time (HH:mm)	Finish time (HH:mm)	Time segment length (min)
D6	2027 Do Something	PM	ONE HOUR	16:45	18:15	15

Vehicle mix source	PCU Factor for a HV (PCU)
HV Percentages	2.00

Demand overview (Traffic)

Arm	Linked arm	Use O-D data	Average Demand (Veh/hr)	Scaling Factor (%)
A		✓	410	100.000
B		✓	276	100.000
C		✓	438	100.000

Origin-Destination Data

Demand (Veh/hr)

		To		
		A	B	C
From	A	0	58	352
	B	77	0	199
	C	211	227	0

Vehicle Mix

Heavy Vehicle Percentages

		To		
		A	B	C
From	A	0	0	2
	B	0	0	0
	C	3	0	0

Results

Results Summary for whole modelled period

Stream	Max RFC	Max Delay (s)	Max Queue (Veh)	Max 95th percentile Queue (Veh)	Max LOS
B-C	0.34	8.28	0.5	2.3	A
B-A	0.24	13.20	0.3	1.4	B
C-A					
C-B	0.37	8.32	0.6	2.7	A
A-B					
A-C					

Main Results for each time segment

16:45 - 17:00

Stream	Total Demand (Veh/hr)	Capacity (Veh/hr)	RFC	Throughput (Veh/hr)	End queue (Veh)	Delay (s)	Unsignalised level of service
B-C	150	721	0.208	149	0.3	6.281	A
B-A	58	447	0.130	57	0.1	9.219	A
C-A	159			159			
C-B	171	726	0.235	170	0.3	6.456	A
A-B	44			44			
A-C	265			265			

17:00 - 17:15

Stream	Total Demand (Veh/hr)	Capacity (Veh/hr)	RFC	Throughput (Veh/hr)	End queue (Veh)	Delay (s)	Unsignalised level of service
B-C	179	695	0.258	179	0.3	6.969	A
B-A	69	410	0.169	69	0.2	10.537	B
C-A	190			190			
C-B	204	708	0.288	204	0.4	7.142	A
A-B	52			52			
A-C	316			316			

17:15 - 17:30

Stream	Total Demand (Veh/hr)	Capacity (Veh/hr)	RFC	Throughput (Veh/hr)	End queue (Veh)	Delay (s)	Unsignalised level of service
B-C	219	654	0.335	218	0.5	8.249	A
B-A	85	358	0.237	84	0.3	13.148	B
C-A	232			232			
C-B	250	682	0.366	249	0.6	8.297	A
A-B	64			64			
A-C	388			388			

17:30 - 17:45

Stream	Total Demand (Veh/hr)	Capacity (Veh/hr)	RFC	Throughput (Veh/hr)	End queue (Veh)	Delay (s)	Unsignalised level of service
B-C	219	654	0.335	219	0.5	8.280	A
B-A	85	357	0.237	85	0.3	13.203	B
C-A	232			232			
C-B	250	682	0.366	250	0.6	8.323	A
A-B	64			64			
A-C	388			388			

17:45 - 18:00

Stream	Total Demand (Veh/hr)	Capacity (Veh/hr)	RFC	Throughput (Veh/hr)	End queue (Veh)	Delay (s)	Unsignalised level of service
B-C	179	694	0.258	179	0.4	7.001	A
B-A	69	410	0.169	70	0.2	10.590	B
C-A	190			190			
C-B	204	708	0.288	205	0.4	7.168	A
A-B	52			52			
A-C	316			316			

18:00 - 18:15

Stream	Total Demand (Veh/hr)	Capacity (Veh/hr)	RFC	Throughput (Veh/hr)	End queue (Veh)	Delay (s)	Unsignalised level of service
B-C	150	720	0.208	150	0.3	6.317	A
B-A	58	447	0.130	58	0.2	9.273	A
C-A	159			159			
C-B	171	726	0.235	171	0.3	6.495	A
A-B	44			44			
A-C	265			265			

Queue Variation Results for each time segment

16:45 - 17:00

Stream	Mean (Veh)	Q05 (Veh)	Q50 (Veh)	Q90 (Veh)	Q95 (Veh)	Percentile message	Marker message	Probability of reaching or exceeding marker	Probability of exactly reaching marker
B-C	0.26	0.00	0.00	0.26	0.26			N/A	N/A
B-A	0.15	0.00	0.00	0.15	0.15			N/A	N/A
C-B	0.30	0.00	0.00	0.30	0.30			N/A	N/A

17:00 - 17:15

Stream	Mean (Veh)	Q05 (Veh)	Q50 (Veh)	Q90 (Veh)	Q95 (Veh)	Percentile message	Marker message	Probability of reaching or exceeding marker	Probability of exactly reaching marker
B-C	0.34	0.00	0.00	0.34	0.34			N/A	N/A
B-A	0.20	0.00	0.00	0.20	0.20			N/A	N/A
C-B	0.40	0.00	0.00	0.40	0.40			N/A	N/A

17:15 - 17:30

Stream	Mean (Veh)	Q05 (Veh)	Q50 (Veh)	Q90 (Veh)	Q95 (Veh)	Percentile message	Marker message	Probability of reaching or exceeding marker	Probability of exactly reaching marker
B-C	0.50	0.03	0.26	0.50	0.50			N/A	N/A
B-A	0.30	0.03	0.26	0.46	0.49			N/A	N/A
C-B	0.57	0.03	0.26	0.57	0.57			N/A	N/A

17:30 - 17:45

Stream	Mean (Veh)	Q05 (Veh)	Q50 (Veh)	Q90 (Veh)	Q95 (Veh)	Percentile message	Marker message	Probability of reaching or exceeding marker	Probability of exactly reaching marker
B-C	0.50	0.03	0.30	1.37	2.27			N/A	N/A
B-A	0.31	0.03	0.31	1.08	1.38			N/A	N/A
C-B	0.57	0.03	0.29	1.27	2.66			N/A	N/A

17:45 - 18:00

Stream	Mean (Veh)	Q05 (Veh)	Q50 (Veh)	Q90 (Veh)	Q95 (Veh)	Percentile message	Marker message	Probability of reaching or exceeding marker	Probability of exactly reaching marker
B-C	0.35	0.00	0.00	0.35	0.35			N/A	N/A
B-A	0.21	0.00	0.00	0.21	0.21			N/A	N/A
C-B	0.41	0.00	0.00	0.41	0.41			N/A	N/A

18:00 - 18:15

Stream	Mean (Veh)	Q05 (Veh)	Q50 (Veh)	Q90 (Veh)	Q95 (Veh)	Percentile message	Marker message	Probability of reaching or exceeding marker	Probability of exactly reaching marker
B-C	0.26	0.00	0.00	0.26	0.26			N/A	N/A
B-A	0.15	0.00	0.00	0.15	0.15			N/A	N/A
C-B	0.31	0.00	0.00	0.31	0.31			N/A	N/A

2032 Do Something (FULL), AM

Data Errors and Warnings

Severity	Area	Item	Description
Warning	Queue variations	Analysis Options	Queue percentiles may be unreliable if the mean queue in any time segment is very low or very high.

Junction Network

Junctions

Junction	Name	Junction type	Major road direction	Use circulating lanes	Junction Delay (s)	Junction LOS
1107A	Poplars Ave central	T-Junction	Two-way		1.21	A

Junction Network Options

Driving side	Lighting
Left	Normal/unknown

Traffic Demand

Demand Set Details

ID	Scenario name	Time Period name	Traffic profile type	Start time (HH:mm)	Finish time (HH:mm)	Time segment length (min)
D7	2032 Do Something (FULL)	AM	ONE HOUR	07:45	09:15	15

Vehicle mix source	PCU Factor for a HV (PCU)
HV Percentages	2.00

Demand overview (Traffic)

Arm	Linked arm	Use O-D data	Average Demand (Veh/hr)	Scaling Factor (%)
A		✓	499	100.000
B		✓	119	100.000
C		✓	300	100.000

Origin-Destination Data

Demand (Veh/hr)

		To		
		A	B	C
From	A	0	31	468
	B	29	0	90
	C	255	45	0

Vehicle Mix

Heavy Vehicle Percentages

		To		
		A	B	C
From	A	0	0	1
	B	0	0	0
	C	3	0	0

Results

Results Summary for whole modelled period

Stream	Max RFC	Max Delay (s)	Max Queue (Veh)	Max 95th percentile Queue (Veh)	Max LOS
B-C	0.15	6.41	0.2	0.5	A
B-A	0.08	9.67	0.1	0.5	A
C-A					
C-B	0.08	5.96	0.1	0.5	A
A-B					
A-C					

Main Results for each time segment

07:45 - 08:00

Stream	Total Demand (Veh/hr)	Capacity (Veh/hr)	RFC	Throughput (Veh/hr)	End queue (Veh)	Delay (s)	Unsignalised level of service
B-C	68	718	0.094	67	0.1	5.529	A
B-A	22	472	0.046	22	0.0	7.995	A
C-A	192			192			
C-B	34	706	0.048	34	0.1	5.349	A
A-B	23			23			
A-C	352			352			

08:00 - 08:15

Stream	Total Demand (Veh/hr)	Capacity (Veh/hr)	RFC	Throughput (Veh/hr)	End queue (Veh)	Delay (s)	Unsignalised level of service
B-C	81	694	0.117	81	0.1	5.871	A
B-A	26	443	0.059	26	0.1	8.624	A
C-A	229			229			
C-B	40	684	0.059	40	0.1	5.590	A
A-B	28			28			
A-C	421			421			

08:15 - 08:30

Stream	Total Demand (Veh/hr)	Capacity (Veh/hr)	RFC	Throughput (Veh/hr)	End queue (Veh)	Delay (s)	Unsignalised level of service
B-C	99	661	0.150	99	0.2	6.407	A
B-A	32	404	0.079	32	0.1	9.671	A
C-A	281			281			
C-B	50	654	0.076	49	0.1	5.957	A
A-B	34			34			
A-C	515			515			

08:30 - 08:45

Stream	Total Demand (Veh/hr)	Capacity (Veh/hr)	RFC	Throughput (Veh/hr)	End queue (Veh)	Delay (s)	Unsignalised level of service
B-C	99	661	0.150	99	0.2	6.411	A
B-A	32	404	0.079	32	0.1	9.675	A
C-A	281			281			
C-B	50	654	0.076	50	0.1	5.957	A
A-B	34			34			
A-C	515			515			

08:45 - 09:00

Stream	Total Demand (Veh/hr)	Capacity (Veh/hr)	RFC	Throughput (Veh/hr)	End queue (Veh)	Delay (s)	Unsignalised level of service
B-C	81	694	0.117	81	0.1	5.875	A
B-A	26	443	0.059	26	0.1	8.631	A
C-A	229			229			
C-B	40	684	0.059	41	0.1	5.591	A
A-B	28			28			
A-C	421			421			

09:00 - 09:15

Stream	Total Demand (Veh/hr)	Capacity (Veh/hr)	RFC	Throughput (Veh/hr)	End queue (Veh)	Delay (s)	Unsignalised level of service
B-C	68	718	0.094	68	0.1	5.541	A
B-A	22	472	0.046	22	0.0	8.005	A
C-A	192			192			
C-B	34	706	0.048	34	0.1	5.354	A
A-B	23			23			
A-C	352			352			

Queue Variation Results for each time segment**07:45 - 08:00**

Stream	Mean (Veh)	Q05 (Veh)	Q50 (Veh)	Q90 (Veh)	Q95 (Veh)	Percentile message	Marker message	Probability of reaching or exceeding marker	Probability of exactly reaching marker
B-C	0.10	0.00	0.00	0.10	0.10			N/A	N/A
B-A	0.05	0.00	0.00	0.05	0.05			N/A	N/A
C-B	0.05	0.00	0.00	0.05	0.05			N/A	N/A

08:00 - 08:15

Stream	Mean (Veh)	Q05 (Veh)	Q50 (Veh)	Q90 (Veh)	Q95 (Veh)	Percentile message	Marker message	Probability of reaching or exceeding marker	Probability of exactly reaching marker
B-C	0.13	0.00	0.00	0.13	0.13			N/A	N/A
B-A	0.06	0.03	0.25	0.45	0.48			N/A	N/A
C-B	0.06	0.03	0.25	0.45	0.48			N/A	N/A

08:15 - 08:30

Stream	Mean (Veh)	Q05 (Veh)	Q50 (Veh)	Q90 (Veh)	Q95 (Veh)	Percentile message	Marker message	Probability of reaching or exceeding marker	Probability of exactly reaching marker
B-C	0.18	0.03	0.26	0.46	0.49			N/A	N/A
B-A	0.08	0.03	0.26	0.47	0.49			N/A	N/A
C-B	0.08	0.03	0.26	0.47	0.49			N/A	N/A

08:30 - 08:45

Stream	Mean (Veh)	Q05 (Veh)	Q50 (Veh)	Q90 (Veh)	Q95 (Veh)	Percentile message	Marker message	Probability of reaching or exceeding marker	Probability of exactly reaching marker
B-C	0.18	0.03	0.25	0.45	0.48			N/A	N/A
B-A	0.09	0.03	0.25	0.45	0.48			N/A	N/A
C-B	0.08	0.00	0.00	0.08	0.08			N/A	N/A

08:45 - 09:00

Stream	Mean (Veh)	Q05 (Veh)	Q50 (Veh)	Q90 (Veh)	Q95 (Veh)	Percentile message	Marker message	Probability of reaching or exceeding marker	Probability of exactly reaching marker
B-C	0.13	0.00	0.00	0.13	0.13			N/A	N/A
B-A	0.06	0.00	0.00	0.06	0.06			N/A	N/A
C-B	0.06	0.00	0.00	0.06	0.06			N/A	N/A

09:00 - 09:15

Stream	Mean (Veh)	Q05 (Veh)	Q50 (Veh)	Q90 (Veh)	Q95 (Veh)	Percentile message	Marker message	Probability of reaching or exceeding marker	Probability of exactly reaching marker
B-C	0.10	0.00	0.00	0.10	0.10			N/A	N/A
B-A	0.05	0.00	0.00	0.05	0.05			N/A	N/A
C-B	0.05	0.00	0.00	0.05	0.05			N/A	N/A

2032 Do Something (FULL), PM

Data Errors and Warnings

Severity	Area	Item	Description
Warning	Queue variations	Analysis Options	Queue percentiles may be unreliable if the mean queue in any time segment is very low or very high.

Junction Network

Junctions

Junction	Name	Junction type	Major road direction	Use circulating lanes	Junction Delay (s)	Junction LOS
1107A	Poplars Ave central	T-Junction	Two-way		1.78	A

Junction Network Options

Driving side	Lighting
Left	Normal/unknown

Traffic Demand

Demand Set Details

ID	Scenario name	Time Period name	Traffic profile type	Start time (HH:mm)	Finish time (HH:mm)	Time segment length (min)
D8	2032 Do Something (FULL)	PM	ONE HOUR	16:45	18:15	15

Vehicle mix source	PCU Factor for a HV (PCU)
HV Percentages	2.00

Demand overview (Traffic)

Arm	Linked arm	Use O-D data	Average Demand (Veh/hr)	Scaling Factor (%)
A		✓	463	100.000
B		✓	135	100.000
C		✓	438	100.000

Origin-Destination Data

Demand (Veh/hr)

		To		
		A	B	C
From	A	0	55	408
	B	47	0	88
	C	319	119	0

Vehicle Mix

Heavy Vehicle Percentages

		To		
		A	B	C
From	A	0	0	2
	B	0	0	0
	C	2	0	0

Results

Results Summary for whole modelled period

Stream	Max RFC	Max Delay (s)	Max Queue (Veh)	Max 95th percentile Queue (Veh)	Max LOS
B-C	0.15	6.42	0.2	0.5	A
B-A	0.13	10.73	0.2	0.5	B
C-A					
C-B	0.20	6.75	0.2	1.1	A
A-B					
A-C					

Main Results for each time segment

16:45 - 17:00

Stream	Total Demand (Veh/hr)	Capacity (Veh/hr)	RFC	Throughput (Veh/hr)	End queue (Veh)	Delay (s)	Unsignalised level of service
B-C	66	714	0.093	66	0.1	5.548	A
B-A	35	467	0.076	35	0.1	8.333	A
C-A	240			240			
C-B	90	714	0.126	89	0.1	5.757	A
A-B	41			41			
A-C	307			307			

17:00 - 17:15

Stream	Total Demand (Veh/hr)	Capacity (Veh/hr)	RFC	Throughput (Veh/hr)	End queue (Veh)	Delay (s)	Unsignalised level of service
B-C	79	691	0.115	79	0.1	5.885	A
B-A	42	433	0.097	42	0.1	9.199	A
C-A	287			287			
C-B	107	693	0.154	107	0.2	6.138	A
A-B	49			49			
A-C	367			367			

17:15 - 17:30

Stream	Total Demand (Veh/hr)	Capacity (Veh/hr)	RFC	Throughput (Veh/hr)	End queue (Veh)	Delay (s)	Unsignalised level of service
B-C	97	657	0.147	97	0.2	6.420	A
B-A	52	387	0.134	52	0.2	10.721	B
C-A	351			351			
C-B	131	664	0.197	131	0.2	6.742	A
A-B	61			61			
A-C	449			449			

17:30 - 17:45

Stream	Total Demand (Veh/hr)	Capacity (Veh/hr)	RFC	Throughput (Veh/hr)	End queue (Veh)	Delay (s)	Unsignalised level of service
B-C	97	657	0.147	97	0.2	6.424	A
B-A	52	387	0.134	52	0.2	10.733	B
C-A	351			351			
C-B	131	664	0.197	131	0.2	6.747	A
A-B	61			61			
A-C	449			449			

17:45 - 18:00

Stream	Total Demand (Veh/hr)	Capacity (Veh/hr)	RFC	Throughput (Veh/hr)	End queue (Veh)	Delay (s)	Unsignalised level of service
B-C	79	691	0.115	79	0.1	5.892	A
B-A	42	433	0.098	42	0.1	9.214	A
C-A	287			287			
C-B	107	693	0.154	107	0.2	6.148	A
A-B	49			49			
A-C	367			367			

18:00 - 18:15

Stream	Total Demand (Veh/hr)	Capacity (Veh/hr)	RFC	Throughput (Veh/hr)	End queue (Veh)	Delay (s)	Unsignalised level of service
B-C	66	714	0.093	66	0.1	5.561	A
B-A	35	467	0.076	35	0.1	8.353	A
C-A	240			240			
C-B	90	714	0.126	90	0.1	5.769	A
A-B	41			41			
A-C	307			307			

Queue Variation Results for each time segment

16:45 - 17:00

Stream	Mean (Veh)	Q05 (Veh)	Q50 (Veh)	Q90 (Veh)	Q95 (Veh)	Percentile message	Marker message	Probability of reaching or exceeding marker	Probability of exactly reaching marker
B-C	0.10	0.00	0.00	0.10	0.10			N/A	N/A
B-A	0.08	0.00	0.00	0.08	0.08			N/A	N/A
C-B	0.14	0.00	0.00	0.14	0.14			N/A	N/A

17:00 - 17:15

Stream	Mean (Veh)	Q05 (Veh)	Q50 (Veh)	Q90 (Veh)	Q95 (Veh)	Percentile message	Marker message	Probability of reaching or exceeding marker	Probability of exactly reaching marker
B-C	0.13	0.00	0.00	0.13	0.13			N/A	N/A
B-A	0.11	0.00	0.00	0.11	0.11			N/A	N/A
C-B	0.18	0.00	0.00	0.18	0.18			N/A	N/A

17:15 - 17:30

Stream	Mean (Veh)	Q05 (Veh)	Q50 (Veh)	Q90 (Veh)	Q95 (Veh)	Percentile message	Marker message	Probability of reaching or exceeding marker	Probability of exactly reaching marker
B-C	0.17	0.03	0.26	0.46	0.49			N/A	N/A
B-A	0.15	0.03	0.26	0.47	0.49			N/A	N/A
C-B	0.24	0.03	0.26	0.46	0.48			N/A	N/A

17:30 - 17:45

Stream	Mean (Veh)	Q05 (Veh)	Q50 (Veh)	Q90 (Veh)	Q95 (Veh)	Percentile message	Marker message	Probability of reaching or exceeding marker	Probability of exactly reaching marker
B-C	0.17	0.03	0.25	0.45	0.48			N/A	N/A
B-A	0.15	0.03	0.25	0.45	0.48			N/A	N/A
C-B	0.24	0.03	0.29	0.71	1.12			N/A	N/A

17:45 - 18:00

Stream	Mean (Veh)	Q05 (Veh)	Q50 (Veh)	Q90 (Veh)	Q95 (Veh)	Percentile message	Marker message	Probability of reaching or exceeding marker	Probability of exactly reaching marker
B-C	0.13	0.00	0.00	0.13	0.13			N/A	N/A
B-A	0.11	0.00	0.00	0.11	0.11			N/A	N/A
C-B	0.18	0.00	0.00	0.18	0.18			N/A	N/A

18:00 - 18:15

Stream	Mean (Veh)	Q05 (Veh)	Q50 (Veh)	Q90 (Veh)	Q95 (Veh)	Percentile message	Marker message	Probability of reaching or exceeding marker	Probability of exactly reaching marker
B-C	0.10	0.00	0.00	0.10	0.10			N/A	N/A
B-A	0.08	0.00	0.00	0.08	0.08			N/A	N/A
C-B	0.14	0.00	0.00	0.14	0.14			N/A	N/A

Arrivals deducted from J4/J5, arrivals added to J3/J6, departures added to J1/J2

Option A Junction J Pass-By Trip Calculations

			2022 DS		2022 DS (F)		2032 DS (F)	
			Existing	New	Existing	New	Existing	New
AM	NewA PAve (C)	J1	7	12	23	28	23	29
		J2	24	37	78	91	78	90
		J3	10	17	35	43	35	45
		J4	104	97	156	148	265	255
		J5	287	266	375	367	486	468
		J6	4	25	13	33	13	31
PM	NewA PAve (C)	J1	5	27	22	44	22	47
		J2	13	48	56	91	56	88
		J3	24	45	96	117	96	119
		J4	168	147	216	195	336	313
		J5	274	241	333	300	439	408
		J6	6	39	24	57	24	55

* = Additional buses added 22/01/20

2022 DS			-	J4 + J5 = Jx	J4/Jx & J5/Jx	Food Store Trips	% x FST
AM Arrival	NewA PAve (C)	J4	104	391	27%	28	7
		J5	287		73%		21
AM Departure		-	-	-	-	18	5
		-	-	-	-		13
PM Arrival		J4	168	442	38%	54	21
		J5	274		62%		33
PM Departure	-	-	-	-	57	22	
	-	-	-	-		35	

Arrivals deducted from J4/J5, arrivals added to J3/J6, departures added to J1/J2

- J1 = + smaller Departure
- J2 = + bigger Departure
- J3 = + smaller Arrival
- J4 = - smaller Arrival
- J5 = - bigger Arrival
- J6 = + bigger Arrival

2022 DS (F)			-	J4 + J5 = Jx	J4/Jx & J5/Jx	Food Store Trips	% x FST
AM Arrival	NewA PAve (C)	J4	156	531	29%	28	8
		J5	375		71%		20
AM Departure		-	-	-	-	18	5
		-	-	-	-		13
PM Arrival		J4	216	549	39%	54	21
		J5	333		61%		33
PM Departure	-	-	-	-	57	22	
	-	-	-	-		35	

2032 DS (F)			-	J4 + J5 = Jx	J4/Jx & J5/Jx	Food Store Trips	% x FST
AM Arrival	NewA PAve (C)	J4	265	751	35%	28	10
		J5	486		65%		18
AM Departure		-	-	-	-	18	6
		-	-	-	-		12
PM Arrival		J4	336	775	43%	54	23
		J5	439		57%		31
PM Departure	-	-	-	-	57	25	
	-	-	-	-		32	

OPTION A
AM Demand

	2022 Do Minimum					2022 Do Something					2022 Do Something (F)					2027 Do Minimum					2027 Do Something					2032 Do Minimum					2032 Do Something (F)														
	LVs	HGV	Buses	HVs	HV%	Total	LVs	HGV	Buses	HVs	HV%	Total	LVs	HGV	Buses	HVs	HV%	Total	LVs	HGV	Buses	HVs	HV%	Total	LVs	HGV	Buses	HVs	HV%	Total	LVs	HGV	Buses	HVs	HV%	Total	LVs	HGV	Buses	HVs	HV%	Total			
A&B/Bic/A	G1	1638	48	8	55	3%	1693	1639	48	8	55	3%	1694	1640	54	8	62	4%	1702	1675	65	8	72	4%	1747	1679	70	8	77	4%	1756	1748	73	8	81	4%	1829	1780	74	8	82	4%	1862		
	G2	2	0	0	0	7%	2	2	0	0	0	7%	2	7	0	0	0	2%	7	2	0	0	0	6%	2	7	0	0	0	2%	7	2	0	0	0	6%	2	7	0	0	0	2%	7		
	G4	20	0	0	0	0%	20	20	0	0	0	0%	20	31	0	0	0	0%	31	21	0	0	0	0%	21	32	0	0	0	0%	32	22	0	0	0	0%	22	33	0	0	0	0%	34		
	G6	1279	82	8	89	7%	1368	1282	82	8	89	7%	1371	1312	82	8	89	6%	1401	1350	82	8	89	6%	1439	1383	82	8	89	6%	1472	1448	83	8	90	6%	1538	1505	82	8	90	6%	1594		
NewA Pave (W)	H1	0	0	0	0	#DIV/0!	0	0	0	0	0	#DIV/0!	0	33	0	0	0	0%	33	0	0	0	0	0	#DIV/0!	0	16	0	0	0	0%	16	0	0	0	0	0	#DIV/0!	0	33	0	0	0	0%	33
	H2	0	0	0	0	#DIV/0!	0	0	0	0	0	#DIV/0!	0	46	0	0	0	0%	46	0	0	0	0	0	#DIV/0!	0	23	0	0	0	0%	23	0	0	0	0	0	#DIV/0!	0	46	0	0	0	0%	46
	H3	0	0	0	0	#DIV/0!	0	0	0	0	0	#DIV/0!	0	23	0	0	0	0%	23	0	0	0	0	0	#DIV/0!	0	12	0	0	0	0%	12	0	0	0	0	0	#DIV/0!	0	23	0	0	0	0%	23
	H4	5	0	8	8	62%	12	5	0	8	8	61%	12	5	0	8	8	61%	12	5	0	8	8	60%	13	5	0	8	8	60%	13	6	0	8	8	58%	13	6	0	8	8	58%	13		
	H5	22	0	5	5	19%	27	22	0	5	5	19%	27	23	0	5	5	19%	28	23	0	5	5	18%	29	24	0	5	5	18%	29	25	0	5	5	17%	30	25	0	5	5	17%	30		
	H6	0	0	0	0	#DIV/0!	0	0	0	0	0	#DIV/0!	0	11	0	0	0	0%	11	0	0	0	0	0	#DIV/0!	0	5	0	0	0	0%	5	0	0	0	0	0	#DIV/0!	0	11	0	0	0	0%	11
NewA Pave (C)	J1	0	0	0	0	#DIV/0!	0	7	0	0	0	0%	12	23	0	0	0	0%	28	0	0	0	0	0	#DIV/0!	0	31	0	0	0	0%	31	0	0	0	0	0	#DIV/0!	0	23	0	0	0	0%	29
	J2	0	0	0	0	#DIV/0!	0	24	0	0	0	0%	37	78	0	0	0	0%	91	0	0	0	0	0	#DIV/0!	0	105	0	0	0	0%	105	0	0	0	0	0	#DIV/0!	0	78	0	0	0	0%	90
	J3	0	0	0	0	#DIV/0!	0	10	0	0	0	0%	17	35	0	0	0	0%	43	0	0	0	0	0	#DIV/0!	0	107	0	0	0	0%	107	0	0	0	0	0	#DIV/0!	0	35	0	0	0	0%	45
	J4	95	1	8	8	8%	103	96	1	8	8	8%	97	148	1	8	8	5%	148	142	1	8	8	5%	150	147	1	8	8	5%	155	200	1	8	8	4%	208	257	1	8	8	3%	255		
	J5	273	1	5	6	2%	280	280	1	5	6	2%	266	369	1	5	6	2%	367	327	1	5	6	2%	334	375	1	5	6	2%	381	391	2	5	7	2%	398	480	1	5	6	1%	468		
	J6	0	0	0	0	#DIV/0!	0	4	0	0	0	0%	25	13	0	0	0	0%	33	0	0	0	0	0	#DIV/0!	0	39	0	0	0	0%	39	0	0	0	0	0	#DIV/0!	0	13	0	0	0	0%	31
MILL/MILL	AD3	376	2	0	2	0%	377	377	2	0	2	0%	379	439	2	0	2	0%	440	399	2	0	2	0%	401	421	2	0	2	0%	423	413	2	0	2	0%	415	452	2	0	2	0%	454		
	AD4	0	0	0	0	#DIV/0!	0	12	0	0	0	0%	12	29	0	0	0	0%	29	0	0	0	0	0	#DIV/0!	0	29	0	0	0	0%	29	0	0	0	0	0	#DIV/0!	0	29	0	0	0	0%	29
	AD5	0	0	0	0	#DIV/0!	0	26	0	0	0	0%	26	67	0	0	0	0%	67	0	0	0	0	0	#DIV/0!	0	67	0	0	0	0%	67	0	0	0	0	0	#DIV/0!	0	70	0	0	0	0%	70
	AD6	0	0	0	0	#DIV/0!	0	5	0	0	0	0%	5	13	0	0	0	0%	13	0	0	0	0	0	#DIV/0!	0	12	0	0	0	0%	12	0	0	0	0	0	#DIV/0!	0	9	0	0	0	0%	9
	AD1	0	0	0	0	#DIV/0!	0	2	0	0	0	0%	2	5	0	0	0	0%	5	0	0	0	0	0	#DIV/0!	0	5	0	0	0	0%	5	0	0	0	0	0	#DIV/0!	0	5	0	0	0	0%	5
	AD2	522	2	0	2	0%	524	523	2	0	2	0%	525	544	2	0	2	0%	547	558	2	0	2	0%	561	567	2	0	2	0%	569	604	2	0	2	0%	607	621	1	0	1	0%	623		
NewA MILL RB	AE2	0	0	0	0	#DIV/0!	0	0	0	0	0	#DIV/0!	0	32	0	0	0	0%	32	0	0	0	0	0	#DIV/0!	0	9	0	0	0	0%	9	0	0	0	0	0	#DIV/0!	0	29	0	0	0	0%	29
	AE3	528	2	0	2	0%	531	555	2	0	2	0%	558	586	2	0	2	0%	588	565	2	0	2	0%	567	631	2	0	2	0%	634	612	2	0	2	0%	614	670	1	0	1	0%	672		
	AE5	378	2	0	2	0%	380	391	2	0	2	0%	393	406	2	0	2	0%	408	401	2	0	2	0%	403	431	2	0	2	0%	432	415	2	0	2	0%	417	439	2	0	2	0%	441		
	AE6	0	0	0	0	#DIV/0!	0	0	0	0	0	#DIV/0!	0	183	0	0	0	0%	183	0	0	0	0	0	#DIV/0!	0	54	0	0	0	0%	54	0	0	0	0	0	#DIV/0!	0	186	0	0	0	0%	186
	AE8	0	0	0	0	#DIV/0!	0	0	0	0	0	#DIV/0!	0	343	0	0	0	0%	343	0	0	0	0	0	#DIV/0!	0	125	0	0	0	0%	125	0	0	0	0	0	#DIV/0!	0	362	0	0	0	0%	362
	AE9	0	0	0	0	#DIV/0!	0	0	0	0	0	#DIV/0!	0	63	0	0	0	0%	63	0	0	0	0	0	#DIV/0!	0	22	0	0	0	0%	22	0	0	0	0	0	#DIV/0!	0	44	0	0	0	0%	44

OPTION A
PM Demand

	2022 Do Minimum					2022 Do Something					2022 Do Something (F)					2027 Do Minimum					2027 Do Something					2032 Do Minimum					2032 Do Something (F)														
	LVs	HGV	Buses	HVs	HV%	Total	LVs	HGV	Buses	HVs	HV%	Total	LVs	HGV	Buses	HVs	HV%	Total	LVs	HGV	Buses	HVs	HV%	Total	LVs	HGV	Buses	HVs	HV%	Total	LVs	HGV	Buses	HVs	HV%	Total	LVs	HGV	Buses	HVs	HV%	Total			
A&B/Bic/A	G1	1698	60	9	69	4%	1767	1697	60	9	69	4%	1766	1709	60	9	69	4%	1778	1781	60	9	69	4%	1850	1812	60	9	69	4%	1881	1882	60	9	69	4%	1952	1910	60	9	69	4%	1980		
	G2	12	0	0	0	1%	12	12	0	0	0	1%	12	22	0	0	0	1%	22	13	0	0	0	1%	13	23	0	0	0	1%	23	13	0	0	0	1%	13	23	0	0	0	1%	23		
	G4	2	0	0	0	1%	2	2	0	0	0	1%	2	8	0	0	0	0%	8	3	0	0	0	1%	3	9	0	0	0	0%	9	3	0	0	0	0	1%	3	9	0	0	0	0%	9	
	G6	1780	43	9	52	3%	1832	1781	43	9	52	3%	1834	1798	43	9	52	3%	1850	1813	43	9	52	3%	1865	1841	42	9	51	3%	1892	1899	41	9	50	3%	1949	1937	41	9	50	3%	1987		
NewA Pave (W)	H1	0	0	0	0	#DIV/0!	0	0	0	0	0	#DIV/0!	0	23	0	0	0	0%	23	0	0	0	0	0	#DIV/0!	0	11	0	0	0	0%	11	0	0	0	0	0	#DIV/0!	0	23	0	0	0	0%	23
	H2	0	0	0	0	#DIV/0!	0	0	0	0	0	#DIV/0!	0	23	0	0	0	0%	23	0	0	0	0	0	#DIV/0!	0	12	0	0	0	0%	12	0	0	0	0	0	#DIV/0!	0	23	0	0	0	0%	23
	H3	0	0	0	0	#DIV/0!	0	0	0	0	0	#DIV/0!	0	48	0	0	0	0%	48	0	0	0	0	0	#DIV/0!	0	24	0	0	0	0%	24	0	0	0	0	0	#DIV/0!	0	48	0	0	0	0%	48
	H4	19	0	6	6	24%	26	20	0	6	6	23%	26	20	0	6	6	23%	26	20	0	6	6	23%	27	21	0	6	6	22%	27	22	0	6	6	22%	28	22	0	6	6	21%	28		
	H5	5	0	6	6	58%	11	5	0	6	6	58%	11	5	0	6	6	57%	11	5	0	6	6	56%	11	5	0	6	6	55%	11	5	0	6	6	55%	11	5	0	6	6	54%	12		
	H6	0	0	0	0	#DIV/0!	0	0	0	0	0	#DIV/0!	0	26	0	0	0	0%	26	0	0	0	0	0	#DIV/0!	0	13	0	0	0	0%	13	0	0	0	0	0	#DIV/0!	0	26	0	0	0	0%	26
NewA Pave (C)	J1	0	0	0	0	#DIV/																																							

Junctions 9

PICADY 9 - Priority Intersection Module

Version: 9.5.1.7462
© Copyright TRL Limited, 2019

For sales and distribution information, program advice and maintenance, contact TRL:
+44 (0)1344 379777 software@trl.co.uk www.trlsoftware.co.uk

The users of this computer program for the solution of an engineering problem are in no way relieved of their responsibility for the correctness of the solution

Filename: 1901 150120 Poplars Avenue West.j9

Path: C:\Users\Charlie\Highgate Transportation\HTp - 1901 - Peel Hall\Modelling\Site Access Junctions\CJ\Poplars Ave W

Report generation date: 22/01/2020 10:16:55

Summary of junction performance

	AM				PM			
	Set ID	Queue (Veh)	Delay (s)	RFC	Set ID	Queue (Veh)	Delay (s)	RFC
2022 Do Something								
Stream B-AC	D1	0.0	0.00	0.00	D2	0.0	0.00	0.00
Stream C-AB		0.0	0.00	0.00		0.0	0.00	0.00
2022 Do Something (FULL)								
Stream B-AC	D3	0.2	8.06	0.16	D4	0.1	7.69	0.10
Stream C-AB		0.0	6.37	0.04		0.1	6.58	0.09
2027 Do Something								
Stream B-AC	D5	0.1	7.29	0.08	D6	0.1	7.16	0.05
Stream C-AB		0.0	6.21	0.02		0.1	6.22	0.05
2032 Do Something (FULL)								
Stream B-AC	D7	0.2	8.07	0.16	D8	0.1	7.69	0.10
Stream C-AB		0.1	6.38	0.05		0.1	6.57	0.09

There are warnings associated with one or more model runs - see the 'Data Errors and Warnings' tables for each Analysis or Demand Set.

Values shown are the highest values encountered over all time segments. Delay is the maximum value of average delay per arriving vehicle.

File summary

File Description

Title	(untitled)
Location	
Site number	
Date	18/05/2016
Version	
Status	(new file)
Identifier	
Client	
Jobnumber	
Enumerator	DESKTOP-MD9GBJC\Fiona
Description	

Units

Distance units	Speed units	Traffic units input	Traffic units results	Flow units	Average delay units	Total delay units	Rate of delay units
m	kph	Veh	Veh	perHour	s	-Min	perMin

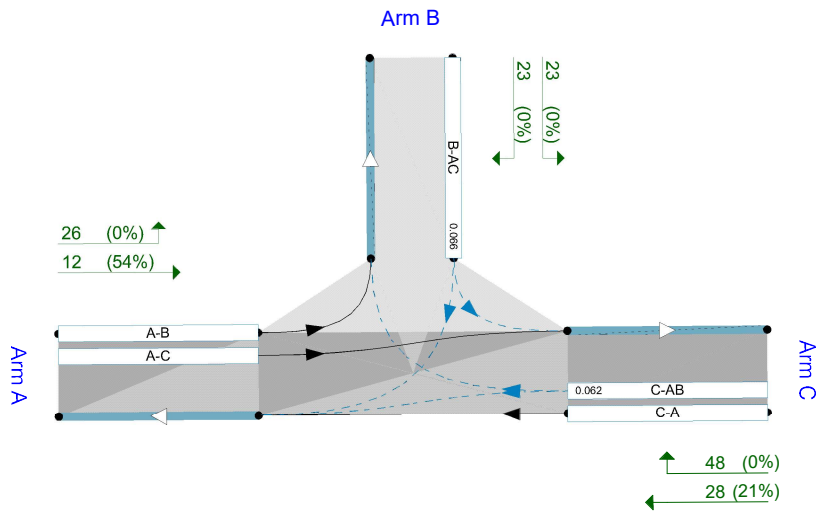

Flows show original traffic demand (Veh/hr).
Streams (downstream end) show RFC (%)

The junction diagram reflects the last run of Junctions.

Analysis Options

Calculate Queue Percentiles	Calculate residual capacity	RFC Threshold	Average Delay threshold (s)	Queue threshold (PCU)
✓		0.85	36.00	20.00

Demand Set Summary

ID	Scenario name	Time Period name	Traffic profile type	Start time (HH:mm)	Finish time (HH:mm)	Time segment length (min)
D1	2022 Do Something	AM	ONE HOUR	07:45	09:15	15
D2	2022 Do Something	PM	ONE HOUR	16:45	18:15	15
D3	2022 Do Something (FULL)	AM	ONE HOUR	07:45	09:15	15
D4	2022 Do Something (FULL)	PM	ONE HOUR	16:45	18:15	15
D5	2027 Do Something	AM	ONE HOUR	07:45	09:15	15
D6	2027 Do Something	PM	ONE HOUR	16:45	18:15	15
D7	2032 Do Something (FULL)	AM	ONE HOUR	07:45	09:15	15
D8	2032 Do Something (FULL)	PM	ONE HOUR	16:45	18:15	15

Analysis Set Details

ID	Network flow scaling factor (%)
A1	100.000

2022 Do Something, AM

Data Errors and Warnings

Severity	Area	Item	Description
Warning	Queue variations	Analysis Options	Queue percentiles may be unreliable if the mean queue in any time segment is very low or very high.

Junction Network

Junctions

Junction	Name	Junction type	Major road direction	Use circulating lanes	Junction Delay (s)	Junction LOS
1	untitled	T-Junction	Two-way		0.00	A

Junction Network Options

Driving side	Lighting
Left	Normal/unknown

Arms

Arms

Arm	Name	Description	Arm type
A	Cotswold Road		Major
B	Site		Minor
C	Poplars Avenue		Major

Major Arm Geometry

Arm	Width of carriageway (m)	Has kerbed central reserve	Has right turn bay	Visibility for right turn (m)	Blocks?	Blocking queue (PCU)
C	7.30			38.0	✓	0.00

Geometries for Arm C are measured opposite Arm B. Geometries for Arm A (if relevant) are measured opposite Arm D.

Minor Arm Geometry

Arm	Minor arm type	Lane width (m)	Visibility to left (m)	Visibility to right (m)
B	One lane	2.20	79	51

Slope / Intercept / Capacity

Priority Intersection Slopes and Intercepts

Stream	Intercept (Veh/hr)	Slope for A-B	Slope for A-C	Slope for C-A	Slope for C-B
B-A	486	0.084	0.211	0.133	0.302
B-C	603	0.087	0.221	-	-
C-B	596	0.218	0.218	-	-

The slopes and intercepts shown above do NOT include any corrections or adjustments.

Streams may be combined, in which case capacity will be adjusted.

Values are shown for the first time segment only; they may differ for subsequent time segments.

Traffic Demand

Demand Set Details

ID	Scenario name	Time Period name	Traffic profile type	Start time (HH:mm)	Finish time (HH:mm)	Time segment length (min)
D1	2022 Do Something	AM	ONE HOUR	07:45	09:15	15

Vehicle mix source	PCU Factor for a HV (PCU)
HV Percentages	2.00

Demand overview (Traffic)

Arm	Linked arm	Use O-D data	Average Demand (Veh/hr)	Scaling Factor (%)
A		✓	27	100.000
B		✓	0	100.000
C		✓	12	100.000

Origin-Destination Data

Demand (Veh/hr)

		To		
		A	B	C
From	A	0	0	27
	B	0	0	0
	C	12	0	0

Vehicle Mix

Heavy Vehicle Percentages

		To		
		A	B	C
From	A	0	0	19
	B	0	0	0
	C	61	0	0

Results

Results Summary for whole modelled period

Stream	Max RFC	Max Delay (s)	Max Queue (Veh)	Max 95th percentile Queue (Veh)	Max LOS
B-AC	0.00	0.00	0.0	~1	A
C-AB	0.00	0.00	0.0	~1	A
C-A					
A-B					
A-C					

Main Results for each time segment

07:45 - 08:00

Stream	Total Demand (Veh/hr)	Capacity (Veh/hr)	RFC	Throughput (Veh/hr)	End queue (Veh)	Delay (s)	Unsignalised level of service
B-AC	0	532	0.000	0	0.0	0.000	A
C-AB	0	453	0.000	0	0.0	0.000	A
C-A	9			9			
A-B	0			0			
A-C	20			20			

08:00 - 08:15

Stream	Total Demand (Veh/hr)	Capacity (Veh/hr)	RFC	Throughput (Veh/hr)	End queue (Veh)	Delay (s)	Unsignalised level of service
B-AC	0	531	0.000	0	0.0	0.000	A
C-AB	0	452	0.000	0	0.0	0.000	A
C-A	11			11			
A-B	0			0			
A-C	24			24			

08:15 - 08:30

Stream	Total Demand (Veh/hr)	Capacity (Veh/hr)	RFC	Throughput (Veh/hr)	End queue (Veh)	Delay (s)	Unsignalised level of service
B-AC	0	529	0.000	0	0.0	0.000	A
C-AB	0	451	0.000	0	0.0	0.000	A
C-A	13			13			
A-B	0			0			
A-C	30			30			

08:30 - 08:45

Stream	Total Demand (Veh/hr)	Capacity (Veh/hr)	RFC	Throughput (Veh/hr)	End queue (Veh)	Delay (s)	Unsignalised level of service
B-AC	0	529	0.000	0	0.0	0.000	A
C-AB	0	451	0.000	0	0.0	0.000	A
C-A	13			13			
A-B	0			0			
A-C	30			30			

08:45 - 09:00

Stream	Total Demand (Veh/hr)	Capacity (Veh/hr)	RFC	Throughput (Veh/hr)	End queue (Veh)	Delay (s)	Unsignalised level of service
B-AC	0	531	0.000	0	0.0	0.000	A
C-AB	0	452	0.000	0	0.0	0.000	A
C-A	11			11			
A-B	0			0			
A-C	24			24			

09:00 - 09:15

Stream	Total Demand (Veh/hr)	Capacity (Veh/hr)	RFC	Throughput (Veh/hr)	End queue (Veh)	Delay (s)	Unsignalised level of service
B-AC	0	532	0.000	0	0.0	0.000	A
C-AB	0	453	0.000	0	0.0	0.000	A
C-A	9			9			
A-B	0			0			
A-C	20			20			

Queue Variation Results for each time segment

07:45 - 08:00

Stream	Mean (Veh)	Q05 (Veh)	Q50 (Veh)	Q90 (Veh)	Q95 (Veh)	Percentile message	Marker message	Probability of reaching or exceeding marker	Probability of exactly reaching marker
B-AC	0.00	0.00	0.00	0.00	0.00			N/A	N/A
C-AB	0.00	0.00	0.00	0.00	0.00			N/A	N/A

08:00 - 08:15

Stream	Mean (Veh)	Q05 (Veh)	Q50 (Veh)	Q90 (Veh)	Q95 (Veh)	Percentile message	Marker message	Probability of reaching or exceeding marker	Probability of exactly reaching marker
B-AC	0.00	0.00	0.00	0.00	0.00			N/A	N/A
C-AB	0.00	0.00	0.00	0.00	0.00			N/A	N/A

08:15 - 08:30

Stream	Mean (Veh)	Q05 (Veh)	Q50 (Veh)	Q90 (Veh)	Q95 (Veh)	Percentile message	Marker message	Probability of reaching or exceeding marker	Probability of exactly reaching marker
B-AC	0.00	0.00	0.00	0.00	0.00			N/A	N/A
C-AB	0.00	0.00	0.00	0.00	0.00			N/A	N/A

08:30 - 08:45

Stream	Mean (Veh)	Q05 (Veh)	Q50 (Veh)	Q90 (Veh)	Q95 (Veh)	Percentile message	Marker message	Probability of reaching or exceeding marker	Probability of exactly reaching marker
B-AC	0.00	0.00	0.00	0.00	0.00			N/A	N/A
C-AB	0.00	0.00	0.00	0.00	0.00			N/A	N/A

08:45 - 09:00

Stream	Mean (Veh)	Q05 (Veh)	Q50 (Veh)	Q90 (Veh)	Q95 (Veh)	Percentile message	Marker message	Probability of reaching or exceeding marker	Probability of exactly reaching marker
B-AC	0.00	0.00	0.00	0.00	0.00			N/A	N/A
C-AB	0.00	0.00	0.00	0.00	0.00			N/A	N/A

09:00 - 09:15

Stream	Mean (Veh)	Q05 (Veh)	Q50 (Veh)	Q90 (Veh)	Q95 (Veh)	Percentile message	Marker message	Probability of reaching or exceeding marker	Probability of exactly reaching marker
B-AC	0.00	0.00	0.00	0.00	0.00			N/A	N/A
C-AB	0.00	0.00	0.00	0.00	0.00			N/A	N/A

2022 Do Something, PM

Data Errors and Warnings

Severity	Area	Item	Description
Warning	Queue variations	Analysis Options	Queue percentiles may be unreliable if the mean queue in any time segment is very low or very high.

Junction Network

Junctions

Junction	Name	Junction type	Major road direction	Use circulating lanes	Junction Delay (s)	Junction LOS
1	untitled	T-Junction	Two-way		0.00	A

Junction Network Options

Driving side	Lighting
Left	Normal/unknown

Traffic Demand

Demand Set Details

ID	Scenario name	Time Period name	Traffic profile type	Start time (HH:mm)	Finish time (HH:mm)	Time segment length (min)
D2	2022 Do Something	PM	ONE HOUR	16:45	18:15	15

Vehicle mix source	PCU Factor for a HV (PCU)
HV Percentages	2.00

Demand overview (Traffic)

Arm	Linked arm	Use O-D data	Average Demand (Veh/hr)	Scaling Factor (%)
A		✓	11	100.000
B		✓	0	100.000
C		✓	26	100.000

Origin-Destination Data

Demand (Veh/hr)

		To		
		A	B	C
From	A	0	0	11
	B	0	0	0
	C	26	0	0

Vehicle Mix

Heavy Vehicle Percentages

		To		
		A	B	C
From	A	0	0	58
	B	0	0	0
	C	23	0	0

Results

Results Summary for whole modelled period

Stream	Max RFC	Max Delay (s)	Max Queue (Veh)	Max 95th percentile Queue (Veh)	Max LOS
B-AC	0.00	0.00	0.0	~1	A
C-AB	0.00	0.00	0.0	~1	A
C-A					
A-B					
A-C					

Main Results for each time segment

16:45 - 17:00

Stream	Total Demand (Veh/hr)	Capacity (Veh/hr)	RFC	Throughput (Veh/hr)	End queue (Veh)	Delay (s)	Unsignalised level of service
B-AC	0	534	0.000	0	0.0	0.000	A
C-AB	0	532	0.000	0	0.0	0.000	A
C-A	20			20			
A-B	0			0			
A-C	8			8			

17:00 - 17:15

Stream	Total Demand (Veh/hr)	Capacity (Veh/hr)	RFC	Throughput (Veh/hr)	End queue (Veh)	Delay (s)	Unsignalised level of service
B-AC	0	533	0.000	0	0.0	0.000	A
C-AB	0	531	0.000	0	0.0	0.000	A
C-A	23			23			
A-B	0			0			
A-C	10			10			

17:15 - 17:30

Stream	Total Demand (Veh/hr)	Capacity (Veh/hr)	RFC	Throughput (Veh/hr)	End queue (Veh)	Delay (s)	Unsignalised level of service
B-AC	0	532	0.000	0	0.0	0.000	A
C-AB	0	531	0.000	0	0.0	0.000	A
C-A	29			29			
A-B	0			0			
A-C	12			12			

17:30 - 17:45

Stream	Total Demand (Veh/hr)	Capacity (Veh/hr)	RFC	Throughput (Veh/hr)	End queue (Veh)	Delay (s)	Unsignalised level of service
B-AC	0	532	0.000	0	0.0	0.000	A
C-AB	0	531	0.000	0	0.0	0.000	A
C-A	29			29			
A-B	0			0			
A-C	12			12			

17:45 - 18:00

Stream	Total Demand (Veh/hr)	Capacity (Veh/hr)	RFC	Throughput (Veh/hr)	End queue (Veh)	Delay (s)	Unsignalised level of service
B-AC	0	533	0.000	0	0.0	0.000	A
C-AB	0	531	0.000	0	0.0	0.000	A
C-A	23			23			
A-B	0			0			
A-C	10			10			

18:00 - 18:15

Stream	Total Demand (Veh/hr)	Capacity (Veh/hr)	RFC	Throughput (Veh/hr)	End queue (Veh)	Delay (s)	Unsignalised level of service
B-AC	0	534	0.000	0	0.0	0.000	A
C-AB	0	532	0.000	0	0.0	0.000	A
C-A	20			20			
A-B	0			0			
A-C	8			8			

Queue Variation Results for each time segment

16:45 - 17:00

Stream	Mean (Veh)	Q05 (Veh)	Q50 (Veh)	Q90 (Veh)	Q95 (Veh)	Percentile message	Marker message	Probability of reaching or exceeding marker	Probability of exactly reaching marker
B-AC	0.00	0.00	0.00	0.00	0.00			N/A	N/A
C-AB	0.00	0.00	0.00	0.00	0.00			N/A	N/A

17:00 - 17:15

Stream	Mean (Veh)	Q05 (Veh)	Q50 (Veh)	Q90 (Veh)	Q95 (Veh)	Percentile message	Marker message	Probability of reaching or exceeding marker	Probability of exactly reaching marker
B-AC	0.00	0.00	0.00	0.00	0.00			N/A	N/A
C-AB	0.00	0.00	0.00	0.00	0.00			N/A	N/A

17:15 - 17:30

Stream	Mean (Veh)	Q05 (Veh)	Q50 (Veh)	Q90 (Veh)	Q95 (Veh)	Percentile message	Marker message	Probability of reaching or exceeding marker	Probability of exactly reaching marker
B-AC	0.00	0.00	0.00	0.00	0.00			N/A	N/A
C-AB	0.00	0.00	0.00	0.00	0.00			N/A	N/A

17:30 - 17:45

Stream	Mean (Veh)	Q05 (Veh)	Q50 (Veh)	Q90 (Veh)	Q95 (Veh)	Percentile message	Marker message	Probability of reaching or exceeding marker	Probability of exactly reaching marker
B-AC	0.00	0.00	0.00	0.00	0.00			N/A	N/A
C-AB	0.00	0.00	0.00	0.00	0.00			N/A	N/A

17:45 - 18:00

Stream	Mean (Veh)	Q05 (Veh)	Q50 (Veh)	Q90 (Veh)	Q95 (Veh)	Percentile message	Marker message	Probability of reaching or exceeding marker	Probability of exactly reaching marker
B-AC	0.00	0.00	0.00	0.00	0.00			N/A	N/A
C-AB	0.00	0.00	0.00	0.00	0.00			N/A	N/A

18:00 - 18:15

Stream	Mean (Veh)	Q05 (Veh)	Q50 (Veh)	Q90 (Veh)	Q95 (Veh)	Percentile message	Marker message	Probability of reaching or exceeding marker	Probability of exactly reaching marker
B-AC	0.00	0.00	0.00	0.00	0.00			N/A	N/A
C-AB	0.00	0.00	0.00	0.00	0.00			N/A	N/A

2022 Do Something (FULL), AM

Data Errors and Warnings

Severity	Area	Item	Description
Warning	Queue variations	Analysis Options	Queue percentiles may be unreliable if the mean queue in any time segment is very low or very high.

Junction Network

Junctions

Junction	Name	Junction type	Major road direction	Use circulating lanes	Junction Delay (s)	Junction LOS
1	untitled	T-Junction	Two-way		4.76	A

Junction Network Options

Driving side	Lighting
Left	Normal/unknown

Traffic Demand

Demand Set Details

ID	Scenario name	Time Period name	Traffic profile type	Start time (HH:mm)	Finish time (HH:mm)	Time segment length (min)
D3	2022 Do Something (FULL)	AM	ONE HOUR	07:45	09:15	15

Vehicle mix source	PCU Factor for a HV (PCU)
HV Percentages	2.00

Demand overview (Traffic)

Arm	Linked arm	Use O-D data	Average Demand (Veh/hr)	Scaling Factor (%)
A		✓	39	100.000
B		✓	79	100.000
C		✓	35	100.000

Origin-Destination Data

Demand (Veh/hr)

		To		
		A	B	C
From	A	0	11	28
	B	33	0	46
	C	12	23	0

Vehicle Mix

Heavy Vehicle Percentages

		To		
		A	B	C
From	A	0	0	19
	B	0	0	0
	C	61	0	0

Results

Results Summary for whole modelled period

Stream	Max RFC	Max Delay (s)	Max Queue (Veh)	Max 95th percentile Queue (Veh)	Max LOS
B-AC	0.16	8.06	0.2	0.5	A
C-AB	0.04	6.37	0.0	0.5	A
C-A					
A-B					
A-C					

Main Results for each time segment

07:45 - 08:00

Stream	Total Demand (Veh/hr)	Capacity (Veh/hr)	RFC	Throughput (Veh/hr)	End queue (Veh)	Delay (s)	Unsignalised level of service
B-AC	59	538	0.111	59	0.1	7.503	A
C-AB	18	593	0.030	17	0.0	6.253	A
C-A	9			9			
A-B	8			8			
A-C	21			21			

08:00 - 08:15

Stream	Total Demand (Veh/hr)	Capacity (Veh/hr)	RFC	Throughput (Veh/hr)	End queue (Veh)	Delay (s)	Unsignalised level of service
B-AC	71	536	0.132	71	0.2	7.734	A
C-AB	21	592	0.036	21	0.0	6.295	A
C-A	10			10			
A-B	10			10			
A-C	25			25			

08:15 - 08:30

Stream	Total Demand (Veh/hr)	Capacity (Veh/hr)	RFC	Throughput (Veh/hr)	End queue (Veh)	Delay (s)	Unsignalised level of service
B-AC	87	534	0.163	87	0.2	8.058	A
C-AB	26	592	0.044	26	0.0	6.355	A
C-A	13			13			
A-B	12			12			
A-C	31			31			

08:30 - 08:45

Stream	Total Demand (Veh/hr)	Capacity (Veh/hr)	RFC	Throughput (Veh/hr)	End queue (Veh)	Delay (s)	Unsignalised level of service
B-AC	87	534	0.163	87	0.2	8.060	A
C-AB	26	592	0.044	26	0.0	6.365	A
C-A	13			13			
A-B	12			12			
A-C	31			31			

08:45 - 09:00

Stream	Total Demand (Veh/hr)	Capacity (Veh/hr)	RFC	Throughput (Veh/hr)	End queue (Veh)	Delay (s)	Unsignalised level of service
B-AC	71	536	0.132	71	0.2	7.744	A
C-AB	21	592	0.036	21	0.0	6.310	A
C-A	10			10			
A-B	10			10			
A-C	25			25			

09:00 - 09:15

Stream	Total Demand (Veh/hr)	Capacity (Veh/hr)	RFC	Throughput (Veh/hr)	End queue (Veh)	Delay (s)	Unsignalised level of service
B-AC	59	538	0.111	60	0.1	7.522	A
C-AB	18	593	0.030	18	0.0	6.265	A
C-A	9			9			
A-B	8			8			
A-C	21			21			

Queue Variation Results for each time segment

07:45 - 08:00

Stream	Mean (Veh)	Q05 (Veh)	Q50 (Veh)	Q90 (Veh)	Q95 (Veh)	Percentile message	Marker message	Probability of reaching or exceeding marker	Probability of exactly reaching marker
B-AC	0.12	0.00	0.00	0.12	0.12			N/A	N/A
C-AB	0.03	0.00	0.00	0.03	0.03			N/A	N/A

08:00 - 08:15

Stream	Mean (Veh)	Q05 (Veh)	Q50 (Veh)	Q90 (Veh)	Q95 (Veh)	Percentile message	Marker message	Probability of reaching or exceeding marker	Probability of exactly reaching marker
B-AC	0.15	0.00	0.00	0.15	0.15			N/A	N/A
C-AB	0.04	0.03	0.25	0.45	0.48			N/A	N/A

08:15 - 08:30

Stream	Mean (Veh)	Q05 (Veh)	Q50 (Veh)	Q90 (Veh)	Q95 (Veh)	Percentile message	Marker message	Probability of reaching or exceeding marker	Probability of exactly reaching marker
B-AC	0.19	0.03	0.26	0.46	0.49			N/A	N/A
C-AB	0.05	0.03	0.25	0.46	0.48			N/A	N/A

08:30 - 08:45

Stream	Mean (Veh)	Q05 (Veh)	Q50 (Veh)	Q90 (Veh)	Q95 (Veh)	Percentile message	Marker message	Probability of reaching or exceeding marker	Probability of exactly reaching marker
B-AC	0.19	0.03	0.26	0.47	0.50			N/A	N/A
C-AB	0.05	0.00	0.00	0.05	0.05			N/A	N/A

08:45 - 09:00

Stream	Mean (Veh)	Q05 (Veh)	Q50 (Veh)	Q90 (Veh)	Q95 (Veh)	Percentile message	Marker message	Probability of reaching or exceeding marker	Probability of exactly reaching marker
B-AC	0.15	0.00	0.00	0.15	0.15			N/A	N/A
C-AB	0.04	0.00	0.00	0.04	0.04			N/A	N/A

09:00 - 09:15

Stream	Mean (Veh)	Q05 (Veh)	Q50 (Veh)	Q90 (Veh)	Q95 (Veh)	Percentile message	Marker message	Probability of reaching or exceeding marker	Probability of exactly reaching marker
B-AC	0.13	0.00	0.00	0.13	0.13			N/A	N/A
C-AB	0.03	0.00	0.00	0.03	0.03			N/A	N/A

2022 Do Something (FULL), PM

Data Errors and Warnings

Severity	Area	Item	Description
Warning	Queue variations	Analysis Options	Queue percentiles may be unreliable if the mean queue in any time segment is very low or very high.

Junction Network

Junctions

Junction	Name	Junction type	Major road direction	Use circulating lanes	Junction Delay (s)	Junction LOS
1	untitled	T-Junction	Two-way		4.05	A

Junction Network Options

Driving side	Lighting
Left	Normal/unknown

Traffic Demand

Demand Set Details

ID	Scenario name	Time Period name	Traffic profile type	Start time (HH:mm)	Finish time (HH:mm)	Time segment length (min)
D4	2022 Do Something (FULL)	PM	ONE HOUR	16:45	18:15	15

Vehicle mix source	PCU Factor for a HV (PCU)
HV Percentages	2.00

Demand overview (Traffic)

Arm	Linked arm	Use O-D data	Average Demand (Veh/hr)	Scaling Factor (%)
A		✓	37	100.000
B		✓	46	100.000
C		✓	74	100.000

Origin-Destination Data

Demand (Veh/hr)

		To		
		A	B	C
From	A	0	26	11
	B	23	0	23
	C	26	48	0

Vehicle Mix

Heavy Vehicle Percentages

		To		
		A	B	C
From	A	0	0	57
	B	0	0	0
	C	23	0	0

Results

Results Summary for whole modelled period

Stream	Max RFC	Max Delay (s)	Max Queue (Veh)	Max 95th percentile Queue (Veh)	Max LOS
B-AC	0.10	7.69	0.1	0.5	A
C-AB	0.09	6.58	0.1	0.5	A
C-A					
A-B					
A-C					

Main Results for each time segment

16:45 - 17:00

Stream	Total Demand (Veh/hr)	Capacity (Veh/hr)	RFC	Throughput (Veh/hr)	End queue (Veh)	Delay (s)	Unsignalised level of service
B-AC	35	525	0.066	34	0.1	7.330	A
C-AB	37	601	0.062	37	0.1	6.386	A
C-A	18			18			
A-B	20			20			
A-C	8			8			

17:00 - 17:15

Stream	Total Demand (Veh/hr)	Capacity (Veh/hr)	RFC	Throughput (Veh/hr)	End queue (Veh)	Delay (s)	Unsignalised level of service
B-AC	41	523	0.079	41	0.1	7.479	A
C-AB	45	601	0.075	45	0.1	6.462	A
C-A	22			22			
A-B	23			23			
A-C	10			10			

17:15 - 17:30

Stream	Total Demand (Veh/hr)	Capacity (Veh/hr)	RFC	Throughput (Veh/hr)	End queue (Veh)	Delay (s)	Unsignalised level of service
B-AC	51	519	0.098	51	0.1	7.685	A
C-AB	56	603	0.092	55	0.1	6.571	A
C-A	26			26			
A-B	29			29			
A-C	12			12			

17:30 - 17:45

Stream	Total Demand (Veh/hr)	Capacity (Veh/hr)	RFC	Throughput (Veh/hr)	End queue (Veh)	Delay (s)	Unsignalised level of service
B-AC	51	519	0.098	51	0.1	7.686	A
C-AB	56	603	0.092	56	0.1	6.580	A
C-A	26			26			
A-B	29			29			
A-C	12			12			

17:45 - 18:00

Stream	Total Demand (Veh/hr)	Capacity (Veh/hr)	RFC	Throughput (Veh/hr)	End queue (Veh)	Delay (s)	Unsignalised level of service
B-AC	41	523	0.079	41	0.1	7.482	A
C-AB	45	601	0.075	45	0.1	6.477	A
C-A	22			22			
A-B	23			23			
A-C	10			10			

18:00 - 18:15

Stream	Total Demand (Veh/hr)	Capacity (Veh/hr)	RFC	Throughput (Veh/hr)	End queue (Veh)	Delay (s)	Unsignalised level of service
B-AC	35	525	0.066	35	0.1	7.338	A
C-AB	37	601	0.062	37	0.1	6.398	A
C-A	18			18			
A-B	20			20			
A-C	8			8			

Queue Variation Results for each time segment

16:45 - 17:00

Stream	Mean (Veh)	Q05 (Veh)	Q50 (Veh)	Q90 (Veh)	Q95 (Veh)	Percentile message	Marker message	Probability of reaching or exceeding marker	Probability of exactly reaching marker
B-AC	0.07	0.00	0.00	0.07	0.07			N/A	N/A
C-AB	0.07	0.00	0.00	0.07	0.07			N/A	N/A

17:00 - 17:15

Stream	Mean (Veh)	Q05 (Veh)	Q50 (Veh)	Q90 (Veh)	Q95 (Veh)	Percentile message	Marker message	Probability of reaching or exceeding marker	Probability of exactly reaching marker
B-AC	0.09	0.03	0.26	0.47	0.50			N/A	N/A
C-AB	0.08	0.03	0.25	0.46	0.48			N/A	N/A

17:15 - 17:30

Stream	Mean (Veh)	Q05 (Veh)	Q50 (Veh)	Q90 (Veh)	Q95 (Veh)	Percentile message	Marker message	Probability of reaching or exceeding marker	Probability of exactly reaching marker
B-AC	0.11	0.03	0.26	0.47	0.49			N/A	N/A
C-AB	0.11	0.03	0.26	0.47	0.49			N/A	N/A

17:30 - 17:45

Stream	Mean (Veh)	Q05 (Veh)	Q50 (Veh)	Q90 (Veh)	Q95 (Veh)	Percentile message	Marker message	Probability of reaching or exceeding marker	Probability of exactly reaching marker
B-AC	0.11	0.03	0.25	0.45	0.48			N/A	N/A
C-AB	0.11	0.03	0.25	0.45	0.48			N/A	N/A

17:45 - 18:00

Stream	Mean (Veh)	Q05 (Veh)	Q50 (Veh)	Q90 (Veh)	Q95 (Veh)	Percentile message	Marker message	Probability of reaching or exceeding marker	Probability of exactly reaching marker
B-AC	0.09	0.00	0.00	0.09	0.09			N/A	N/A
C-AB	0.09	0.00	0.00	0.09	0.09			N/A	N/A

18:00 - 18:15

Stream	Mean (Veh)	Q05 (Veh)	Q50 (Veh)	Q90 (Veh)	Q95 (Veh)	Percentile message	Marker message	Probability of reaching or exceeding marker	Probability of exactly reaching marker
B-AC	0.07	0.00	0.00	0.07	0.07			N/A	N/A
C-AB	0.07	0.00	0.00	0.07	0.07			N/A	N/A

2027 Do Something, AM

Data Errors and Warnings

Severity	Area	Item	Description
Warning	Queue variations	Analysis Options	Queue percentiles may be unreliable if the mean queue in any time segment is very low or very high.

Junction Network

Junctions

Junction	Name	Junction type	Major road direction	Use circulating lanes	Junction Delay (s)	Junction LOS
1	untitled	T-Junction	Two-way		3.25	A

Junction Network Options

Driving side	Lighting
Left	Normal/unknown

Traffic Demand

Demand Set Details

ID	Scenario name	Time Period name	Traffic profile type	Start time (HH:mm)	Finish time (HH:mm)	Time segment length (min)
D5	2027 Do Something	AM	ONE HOUR	07:45	09:15	15

Vehicle mix source	PCU Factor for a HV (PCU)
HV Percentages	2.00

Demand overview (Traffic)

Arm	Linked arm	Use O-D data	Average Demand (Veh/hr)	Scaling Factor (%)
A		✓	34	100.000
B		✓	39	100.000
C		✓	25	100.000

Origin-Destination Data

Demand (Veh/hr)

		To		
		A	B	C
From	A	0	5	29
	B	16	0	23
	C	13	12	0

Vehicle Mix

Heavy Vehicle Percentages

		To		
		A	B	C
From	A	0	0	18
	B	0	0	0
	C	60	0	0

Results

Results Summary for whole modelled period

Stream	Max RFC	Max Delay (s)	Max Queue (Veh)	Max 95th percentile Queue (Veh)	Max LOS
B-AC	0.08	7.29	0.1	0.5	A
C-AB	0.02	6.21	0.0	0.5	A
C-A					
A-B					
A-C					

Main Results for each time segment

07:45 - 08:00

Stream	Total Demand (Veh/hr)	Capacity (Veh/hr)	RFC	Throughput (Veh/hr)	End queue (Veh)	Delay (s)	Unsignalised level of service
B-AC	29	541	0.054	29	0.1	7.033	A
C-AB	9	594	0.015	9	0.0	6.153	A
C-A	10			10			
A-B	4			4			
A-C	22			22			

08:00 - 08:15

Stream	Total Demand (Veh/hr)	Capacity (Veh/hr)	RFC	Throughput (Veh/hr)	End queue (Veh)	Delay (s)	Unsignalised level of service
B-AC	35	539	0.065	35	0.1	7.142	A
C-AB	11	594	0.019	11	0.0	6.170	A
C-A	11			11			
A-B	4			4			
A-C	26			26			

08:15 - 08:30

Stream	Total Demand (Veh/hr)	Capacity (Veh/hr)	RFC	Throughput (Veh/hr)	End queue (Veh)	Delay (s)	Unsignalised level of service
B-AC	43	537	0.080	43	0.1	7.289	A
C-AB	14	593	0.023	14	0.0	6.200	A
C-A	14			14			
A-B	6			6			
A-C	32			32			

08:30 - 08:45

Stream	Total Demand (Veh/hr)	Capacity (Veh/hr)	RFC	Throughput (Veh/hr)	End queue (Veh)	Delay (s)	Unsignalised level of service
B-AC	43	537	0.080	43	0.1	7.289	A
C-AB	14	593	0.023	14	0.0	6.208	A
C-A	14			14			
A-B	6			6			
A-C	32			32			

08:45 - 09:00

Stream	Total Demand (Veh/hr)	Capacity (Veh/hr)	RFC	Throughput (Veh/hr)	End queue (Veh)	Delay (s)	Unsignalised level of service
B-AC	35	539	0.065	35	0.1	7.144	A
C-AB	11	594	0.019	11	0.0	6.188	A
C-A	11			11			
A-B	4			4			
A-C	26			26			

09:00 - 09:15

Stream	Total Demand (Veh/hr)	Capacity (Veh/hr)	RFC	Throughput (Veh/hr)	End queue (Veh)	Delay (s)	Unsignalised level of service
B-AC	29	541	0.054	29	0.1	7.043	A
C-AB	9	594	0.015	9	0.0	6.162	A
C-A	10			10			
A-B	4			4			
A-C	22			22			

Queue Variation Results for each time segment

07:45 - 08:00

Stream	Mean (Veh)	Q05 (Veh)	Q50 (Veh)	Q90 (Veh)	Q95 (Veh)	Percentile message	Marker message	Probability of reaching or exceeding marker	Probability of exactly reaching marker
B-AC	0.06	0.00	0.00	0.06	0.06			N/A	N/A
C-AB	0.02	0.00	0.00	0.02	0.02			N/A	N/A

08:00 - 08:15

Stream	Mean (Veh)	Q05 (Veh)	Q50 (Veh)	Q90 (Veh)	Q95 (Veh)	Percentile message	Marker message	Probability of reaching or exceeding marker	Probability of exactly reaching marker
B-AC	0.07	0.03	0.25	0.45	0.48			N/A	N/A
C-AB	0.02	0.02	0.25	0.45	0.48			N/A	N/A

08:15 - 08:30

Stream	Mean (Veh)	Q05 (Veh)	Q50 (Veh)	Q90 (Veh)	Q95 (Veh)	Percentile message	Marker message	Probability of reaching or exceeding marker	Probability of exactly reaching marker
B-AC	0.09	0.03	0.26	0.47	0.49			N/A	N/A
C-AB	0.02	0.00	0.00	0.02	0.02			N/A	N/A

08:30 - 08:45

Stream	Mean (Veh)	Q05 (Veh)	Q50 (Veh)	Q90 (Veh)	Q95 (Veh)	Percentile message	Marker message	Probability of reaching or exceeding marker	Probability of exactly reaching marker
B-AC	0.09	0.00	0.00	0.09	0.09			N/A	N/A
C-AB	0.03	0.00	0.00	0.03	0.03			N/A	N/A

08:45 - 09:00

Stream	Mean (Veh)	Q05 (Veh)	Q50 (Veh)	Q90 (Veh)	Q95 (Veh)	Percentile message	Marker message	Probability of reaching or exceeding marker	Probability of exactly reaching marker
B-AC	0.07	0.00	0.00	0.07	0.07			N/A	N/A
C-AB	0.02	0.00	0.00	0.02	0.02			N/A	N/A

09:00 - 09:15

Stream	Mean (Veh)	Q05 (Veh)	Q50 (Veh)	Q90 (Veh)	Q95 (Veh)	Percentile message	Marker message	Probability of reaching or exceeding marker	Probability of exactly reaching marker
B-AC	0.06	0.00	0.00	0.06	0.06			N/A	N/A
C-AB	0.02	0.00	0.00	0.02	0.02			N/A	N/A

2027 Do Something, PM

Data Errors and Warnings

Severity	Area	Item	Description
Warning	Queue variations	Analysis Options	Queue percentiles may be unreliable if the mean queue in any time segment is very low or very high.

Junction Network

Junctions

Junction	Name	Junction type	Major road direction	Use circulating lanes	Junction Delay (s)	Junction LOS
1	untitled	T-Junction	Two-way		2.93	A

Junction Network Options

Driving side	Lighting
Left	Normal/unknown

Traffic Demand

Demand Set Details

ID	Scenario name	Time Period name	Traffic profile type	Start time (HH:mm)	Finish time (HH:mm)	Time segment length (min)
D6	2027 Do Something	PM	ONE HOUR	16:45	18:15	15

Vehicle mix source	PCU Factor for a HV (PCU)
HV Percentages	2.00

Demand overview (Traffic)

Arm	Linked arm	Use O-D data	Average Demand (Veh/hr)	Scaling Factor (%)
A		✓	24	100.000
B		✓	23	100.000
C		✓	51	100.000

Origin-Destination Data

Demand (Veh/hr)

		To		
		A	B	C
From	A	0	13	11
	B	11	0	12
	C	27	24	0

Vehicle Mix

Heavy Vehicle Percentages

		To		
		A	B	C
From	A	0	0	55
	B	0	0	0
	C	22	0	0

Results

Results Summary for whole modelled period

Stream	Max RFC	Max Delay (s)	Max Queue (Veh)	Max 95th percentile Queue (Veh)	Max LOS
B-AC	0.05	7.16	0.1	0.5	A
C-AB	0.05	6.22	0.1	0.5	A
C-A					
A-B					
A-C					

Main Results for each time segment

16:45 - 17:00

Stream	Total Demand (Veh/hr)	Capacity (Veh/hr)	RFC	Throughput (Veh/hr)	End queue (Veh)	Delay (s)	Unsignalised level of service
B-AC	17	532	0.033	17	0.0	6.987	A
C-AB	19	603	0.031	19	0.0	6.155	A
C-A	20			20			
A-B	10			10			
A-C	8			8			

17:00 - 17:15

Stream	Total Demand (Veh/hr)	Capacity (Veh/hr)	RFC	Throughput (Veh/hr)	End queue (Veh)	Delay (s)	Unsignalised level of service
B-AC	21	530	0.039	21	0.0	7.060	A
C-AB	22	605	0.037	22	0.0	6.179	A
C-A	23			23			
A-B	12			12			
A-C	10			10			

17:15 - 17:30

Stream	Total Demand (Veh/hr)	Capacity (Veh/hr)	RFC	Throughput (Veh/hr)	End queue (Veh)	Delay (s)	Unsignalised level of service
B-AC	25	528	0.048	25	0.0	7.159	A
C-AB	28	607	0.046	28	0.1	6.213	A
C-A	28			28			
A-B	14			14			
A-C	12			12			

17:30 - 17:45

Stream	Total Demand (Veh/hr)	Capacity (Veh/hr)	RFC	Throughput (Veh/hr)	End queue (Veh)	Delay (s)	Unsignalised level of service
B-AC	25	528	0.048	25	0.1	7.159	A
C-AB	28	607	0.046	28	0.1	6.219	A
C-A	28			28			
A-B	14			14			
A-C	12			12			

17:45 - 18:00

Stream	Total Demand (Veh/hr)	Capacity (Veh/hr)	RFC	Throughput (Veh/hr)	End queue (Veh)	Delay (s)	Unsignalised level of service
B-AC	21	530	0.039	21	0.0	7.061	A
C-AB	22	605	0.037	23	0.0	6.193	A
C-A	23			23			
A-B	12			12			
A-C	10			10			

18:00 - 18:15

Stream	Total Demand (Veh/hr)	Capacity (Veh/hr)	RFC	Throughput (Veh/hr)	End queue (Veh)	Delay (s)	Unsignalised level of service
B-AC	17	532	0.033	17	0.0	6.994	A
C-AB	19	603	0.031	19	0.0	6.164	A
C-A	20			20			
A-B	10			10			
A-C	8			8			

Queue Variation Results for each time segment

16:45 - 17:00

Stream	Mean (Veh)	Q05 (Veh)	Q50 (Veh)	Q90 (Veh)	Q95 (Veh)	Percentile message	Marker message	Probability of reaching or exceeding marker	Probability of exactly reaching marker
B-AC	0.03	0.00	0.00	0.03	0.03			N/A	N/A
C-AB	0.03	0.00	0.00	0.03	0.03			N/A	N/A

17:00 - 17:15

Stream	Mean (Veh)	Q05 (Veh)	Q50 (Veh)	Q90 (Veh)	Q95 (Veh)	Percentile message	Marker message	Probability of reaching or exceeding marker	Probability of exactly reaching marker
B-AC	0.04	0.03	0.25	0.45	0.48			N/A	N/A
C-AB	0.04	0.03	0.25	0.45	0.48			N/A	N/A

17:15 - 17:30

Stream	Mean (Veh)	Q05 (Veh)	Q50 (Veh)	Q90 (Veh)	Q95 (Veh)	Percentile message	Marker message	Probability of reaching or exceeding marker	Probability of exactly reaching marker
B-AC	0.05	0.03	0.26	0.46	0.49			N/A	N/A
C-AB	0.05	0.03	0.26	0.46	0.49			N/A	N/A

17:30 - 17:45

Stream	Mean (Veh)	Q05 (Veh)	Q50 (Veh)	Q90 (Veh)	Q95 (Veh)	Percentile message	Marker message	Probability of reaching or exceeding marker	Probability of exactly reaching marker
B-AC	0.05	0.00	0.00	0.05	0.05			N/A	N/A
C-AB	0.05	0.00	0.00	0.05	0.05			N/A	N/A

17:45 - 18:00

Stream	Mean (Veh)	Q05 (Veh)	Q50 (Veh)	Q90 (Veh)	Q95 (Veh)	Percentile message	Marker message	Probability of reaching or exceeding marker	Probability of exactly reaching marker
B-AC	0.04	0.00	0.00	0.04	0.04			N/A	N/A
C-AB	0.04	0.00	0.00	0.04	0.04			N/A	N/A

18:00 - 18:15

Stream	Mean (Veh)	Q05 (Veh)	Q50 (Veh)	Q90 (Veh)	Q95 (Veh)	Percentile message	Marker message	Probability of reaching or exceeding marker	Probability of exactly reaching marker
B-AC	0.03	0.00	0.00	0.03	0.03			N/A	N/A
C-AB	0.03	0.00	0.00	0.03	0.03			N/A	N/A

2032 Do Something (FULL), AM

Data Errors and Warnings

Severity	Area	Item	Description
Warning	Queue variations	Analysis Options	Queue percentiles may be unreliable if the mean queue in any time segment is very low or very high.

Junction Network

Junctions

Junction	Name	Junction type	Major road direction	Use circulating lanes	Junction Delay (s)	Junction LOS
1	untitled	T-Junction	Two-way		4.76	A

Junction Network Options

Driving side	Lighting
Left	Normal/unknown

Traffic Demand

Demand Set Details

ID	Scenario name	Time Period name	Traffic profile type	Start time (HH:mm)	Finish time (HH:mm)	Time segment length (min)
D7	2032 Do Something (FULL)	AM	ONE HOUR	07:45	09:15	15

Vehicle mix source	PCU Factor for a HV (PCU)
HV Percentages	2.00

Demand overview (Traffic)

Arm	Linked arm	Use O-D data	Average Demand (Veh/hr)	Scaling Factor (%)
A		✓	39	100.000
B		✓	79	100.000
C		✓	38	100.000

Origin-Destination Data

Demand (Veh/hr)

		To		
		A	B	C
From	A	0	9	30
	B	33	0	46
	C	13	25	0

Vehicle Mix

Heavy Vehicle Percentages

		To		
		A	B	C
From	A	0	0	17
	B	0	0	0
	C	58	0	0

Results

Results Summary for whole modelled period

Stream	Max RFC	Max Delay (s)	Max Queue (Veh)	Max 95th percentile Queue (Veh)	Max LOS
B-AC	0.16	8.07	0.2	0.5	A
C-AB	0.05	6.38	0.1	0.5	A
C-A					
A-B					
A-C					

Main Results for each time segment

07:45 - 08:00

Stream	Total Demand (Veh/hr)	Capacity (Veh/hr)	RFC	Throughput (Veh/hr)	End queue (Veh)	Delay (s)	Unsignalised level of service
B-AC	59	538	0.111	59	0.1	7.510	A
C-AB	19	593	0.032	19	0.0	6.265	A
C-A	9			9			
A-B	7			7			
A-C	23			23			

08:00 - 08:15

Stream	Total Demand (Veh/hr)	Capacity (Veh/hr)	RFC	Throughput (Veh/hr)	End queue (Veh)	Delay (s)	Unsignalised level of service
B-AC	71	536	0.133	71	0.2	7.743	A
C-AB	23	593	0.039	23	0.0	6.309	A
C-A	11			11			
A-B	8			8			
A-C	27			27			

08:15 - 08:30

Stream	Total Demand (Veh/hr)	Capacity (Veh/hr)	RFC	Throughput (Veh/hr)	End queue (Veh)	Delay (s)	Unsignalised level of service
B-AC	87	533	0.163	87	0.2	8.071	A
C-AB	28	592	0.048	28	0.1	6.373	A
C-A	14			14			
A-B	10			10			
A-C	33			33			

08:30 - 08:45

Stream	Total Demand (Veh/hr)	Capacity (Veh/hr)	RFC	Throughput (Veh/hr)	End queue (Veh)	Delay (s)	Unsignalised level of service
B-AC	87	533	0.163	87	0.2	8.073	A
C-AB	28	592	0.048	28	0.1	6.381	A
C-A	14			14			
A-B	10			10			
A-C	33			33			

08:45 - 09:00

Stream	Total Demand (Veh/hr)	Capacity (Veh/hr)	RFC	Throughput (Veh/hr)	End queue (Veh)	Delay (s)	Unsignalised level of service
B-AC	71	536	0.133	71	0.2	7.753	A
C-AB	23	593	0.039	23	0.0	6.327	A
C-A	11			11			
A-B	8			8			
A-C	27			27			

09:00 - 09:15

Stream	Total Demand (Veh/hr)	Capacity (Veh/hr)	RFC	Throughput (Veh/hr)	End queue (Veh)	Delay (s)	Unsignalised level of service
B-AC	59	538	0.111	60	0.1	7.529	A
C-AB	19	593	0.032	19	0.0	6.275	A
C-A	9			9			
A-B	7			7			
A-C	23			23			

Queue Variation Results for each time segment

07:45 - 08:00

Stream	Mean (Veh)	Q05 (Veh)	Q50 (Veh)	Q90 (Veh)	Q95 (Veh)	Percentile message	Marker message	Probability of reaching or exceeding marker	Probability of exactly reaching marker
B-AC	0.12	0.00	0.00	0.12	0.12			N/A	N/A
C-AB	0.03	0.00	0.00	0.03	0.03			N/A	N/A

08:00 - 08:15

Stream	Mean (Veh)	Q05 (Veh)	Q50 (Veh)	Q90 (Veh)	Q95 (Veh)	Percentile message	Marker message	Probability of reaching or exceeding marker	Probability of exactly reaching marker
B-AC	0.15	0.00	0.00	0.15	0.15			N/A	N/A
C-AB	0.04	0.03	0.25	0.45	0.48			N/A	N/A

08:15 - 08:30

Stream	Mean (Veh)	Q05 (Veh)	Q50 (Veh)	Q90 (Veh)	Q95 (Veh)	Percentile message	Marker message	Probability of reaching or exceeding marker	Probability of exactly reaching marker
B-AC	0.19	0.03	0.26	0.46	0.49			N/A	N/A
C-AB	0.05	0.03	0.26	0.46	0.49			N/A	N/A

08:30 - 08:45

Stream	Mean (Veh)	Q05 (Veh)	Q50 (Veh)	Q90 (Veh)	Q95 (Veh)	Percentile message	Marker message	Probability of reaching or exceeding marker	Probability of exactly reaching marker
B-AC	0.19	0.03	0.26	0.47	0.50			N/A	N/A
C-AB	0.05	0.00	0.00	0.05	0.05			N/A	N/A

08:45 - 09:00

Stream	Mean (Veh)	Q05 (Veh)	Q50 (Veh)	Q90 (Veh)	Q95 (Veh)	Percentile message	Marker message	Probability of reaching or exceeding marker	Probability of exactly reaching marker
B-AC	0.15	0.00	0.00	0.15	0.15			N/A	N/A
C-AB	0.04	0.00	0.00	0.04	0.04			N/A	N/A

09:00 - 09:15

Stream	Mean (Veh)	Q05 (Veh)	Q50 (Veh)	Q90 (Veh)	Q95 (Veh)	Percentile message	Marker message	Probability of reaching or exceeding marker	Probability of exactly reaching marker
B-AC	0.13	0.00	0.00	0.13	0.13			N/A	N/A
C-AB	0.04	0.00	0.00	0.04	0.04			N/A	N/A

2032 Do Something (FULL), PM

Data Errors and Warnings

Severity	Area	Item	Description
Warning	Queue variations	Analysis Options	Queue percentiles may be unreliable if the mean queue in any time segment is very low or very high.

Junction Network

Junctions

Junction	Name	Junction type	Major road direction	Use circulating lanes	Junction Delay (s)	Junction LOS
1	untitled	T-Junction	Two-way		3.98	A

Junction Network Options

Driving side	Lighting
Left	Normal/unknown

Traffic Demand

Demand Set Details

ID	Scenario name	Time Period name	Traffic profile type	Start time (HH:mm)	Finish time (HH:mm)	Time segment length (min)
D8	2032 Do Something (FULL)	PM	ONE HOUR	16:45	18:15	15

Vehicle mix source	PCU Factor for a HV (PCU)
HV Percentages	2.00

Demand overview (Traffic)

Arm	Linked arm	Use O-D data	Average Demand (Veh/hr)	Scaling Factor (%)
A		✓	38	100.000
B		✓	46	100.000
C		✓	76	100.000

Origin-Destination Data

Demand (Veh/hr)

		To		
		A	B	C
From	A	0	26	12
	B	23	0	23
	C	28	48	0

Vehicle Mix

Heavy Vehicle Percentages

		To		
		A	B	C
From	A	0	0	54
	B	0	0	0
	C	21	0	0

Results

Results Summary for whole modelled period

Stream	Max RFC	Max Delay (s)	Max Queue (Veh)	Max 95th percentile Queue (Veh)	Max LOS
B-AC	0.10	7.69	0.1	0.5	A
C-AB	0.09	6.57	0.1	0.5	A
C-A					
A-B					
A-C					

Main Results for each time segment

16:45 - 17:00

Stream	Total Demand (Veh/hr)	Capacity (Veh/hr)	RFC	Throughput (Veh/hr)	End queue (Veh)	Delay (s)	Unsignalised level of service
B-AC	35	525	0.066	34	0.1	7.335	A
C-AB	37	601	0.062	37	0.1	6.377	A
C-A	20			20			
A-B	20			20			
A-C	9			9			

17:00 - 17:15

Stream	Total Demand (Veh/hr)	Capacity (Veh/hr)	RFC	Throughput (Veh/hr)	End queue (Veh)	Delay (s)	Unsignalised level of service
B-AC	41	522	0.079	41	0.1	7.485	A
C-AB	45	602	0.075	45	0.1	6.452	A
C-A	23			23			
A-B	23			23			
A-C	11			11			

17:15 - 17:30

Stream	Total Demand (Veh/hr)	Capacity (Veh/hr)	RFC	Throughput (Veh/hr)	End queue (Veh)	Delay (s)	Unsignalised level of service
B-AC	51	519	0.098	51	0.1	7.693	A
C-AB	56	604	0.092	56	0.1	6.559	A
C-A	28			28			
A-B	29			29			
A-C	13			13			

17:30 - 17:45

Stream	Total Demand (Veh/hr)	Capacity (Veh/hr)	RFC	Throughput (Veh/hr)	End queue (Veh)	Delay (s)	Unsignalised level of service
B-AC	51	519	0.098	51	0.1	7.694	A
C-AB	56	604	0.092	56	0.1	6.568	A
C-A	28			28			
A-B	29			29			
A-C	13			13			

17:45 - 18:00

Stream	Total Demand (Veh/hr)	Capacity (Veh/hr)	RFC	Throughput (Veh/hr)	End queue (Veh)	Delay (s)	Unsignalised level of service
B-AC	41	522	0.079	41	0.1	7.491	A
C-AB	45	602	0.075	45	0.1	6.470	A
C-A	23			23			
A-B	23			23			
A-C	11			11			

18:00 - 18:15

Stream	Total Demand (Veh/hr)	Capacity (Veh/hr)	RFC	Throughput (Veh/hr)	End queue (Veh)	Delay (s)	Unsignalised level of service
B-AC	35	525	0.066	35	0.1	7.343	A
C-AB	37	601	0.062	38	0.1	6.390	A
C-A	20			20			
A-B	20			20			
A-C	9			9			

Queue Variation Results for each time segment

16:45 - 17:00

Stream	Mean (Veh)	Q05 (Veh)	Q50 (Veh)	Q90 (Veh)	Q95 (Veh)	Percentile message	Marker message	Probability of reaching or exceeding marker	Probability of exactly reaching marker
B-AC	0.07	0.00	0.00	0.07	0.07			N/A	N/A
C-AB	0.07	0.00	0.00	0.07	0.07			N/A	N/A

17:00 - 17:15

Stream	Mean (Veh)	Q05 (Veh)	Q50 (Veh)	Q90 (Veh)	Q95 (Veh)	Percentile message	Marker message	Probability of reaching or exceeding marker	Probability of exactly reaching marker
B-AC	0.09	0.03	0.26	0.47	0.50			N/A	N/A
C-AB	0.09	0.03	0.25	0.46	0.48			N/A	N/A

17:15 - 17:30

Stream	Mean (Veh)	Q05 (Veh)	Q50 (Veh)	Q90 (Veh)	Q95 (Veh)	Percentile message	Marker message	Probability of reaching or exceeding marker	Probability of exactly reaching marker
B-AC	0.11	0.03	0.26	0.47	0.49			N/A	N/A
C-AB	0.11	0.03	0.26	0.47	0.49			N/A	N/A

17:30 - 17:45

Stream	Mean (Veh)	Q05 (Veh)	Q50 (Veh)	Q90 (Veh)	Q95 (Veh)	Percentile message	Marker message	Probability of reaching or exceeding marker	Probability of exactly reaching marker
B-AC	0.11	0.03	0.25	0.45	0.48			N/A	N/A
C-AB	0.11	0.03	0.25	0.45	0.48			N/A	N/A

17:45 - 18:00

Stream	Mean (Veh)	Q05 (Veh)	Q50 (Veh)	Q90 (Veh)	Q95 (Veh)	Percentile message	Marker message	Probability of reaching or exceeding marker	Probability of exactly reaching marker
B-AC	0.09	0.00	0.00	0.09	0.09			N/A	N/A
C-AB	0.09	0.00	0.00	0.09	0.09			N/A	N/A

18:00 - 18:15

Stream	Mean (Veh)	Q05 (Veh)	Q50 (Veh)	Q90 (Veh)	Q95 (Veh)	Percentile message	Marker message	Probability of reaching or exceeding marker	Probability of exactly reaching marker
B-AC	0.07	0.00	0.00	0.07	0.07			N/A	N/A
C-AB	0.07	0.00	0.00	0.07	0.07			N/A	N/A

Junctions 9

PICADY 9 - Priority Intersection Module

Version: 9.5.1.7462
© Copyright TRL Limited, 2019

For sales and distribution information, program advice and maintenance, contact TRL:
+44 (0)1344 379777 software@trl.co.uk www.trlsoftware.co.uk

The users of this computer program for the solution of an engineering problem are in no way relieved of their responsibility for the correctness of the solution

Filename: 1901 050320 Mill Lane Turn Off 2019 Calibration.j9

Path: C:\Users\Charlie\Highgate Transportation\HTp - 1901 - Peel Hall\Modelling\Site Access Junctions\CJ\Option A\Mill Lane

Report generation date: 05/03/2020 11:59:37

Summary of junction performance

	AM					PM				
	Set ID	Queue (Veh)	Delay (s)	RFC	LOS	Set ID	Queue (Veh)	Delay (s)	RFC	LOS
2022 Do Minimum										
Stream B-C	D1	0.0	5.55	0.02	A	D2	0.0	6.41	0.01	A
Stream B-A		0.1	10.96	0.05	B		0.1	10.48	0.07	B
Stream C-AB		0.0	8.38	0.01	A		0.0	7.41	0.04	A
2022 Do Something										
Stream B-C	D3	0.0	5.73	0.03	A	D4	0.0	6.33	0.02	A
Stream B-A		0.2	11.58	0.13	B		0.1	11.18	0.12	B
Stream C-AB		0.0	7.88	0.01	A		0.1	7.45	0.05	A
2022 Do Something (FULL)										
Stream B-C	D5	0.0	6.26	0.04	A	D6	0.0	6.52	0.03	A
Stream B-A		0.4	14.60	0.27	B		0.3	13.08	0.20	B
Stream C-AB		0.0	7.82	0.02	A		0.1	7.56	0.06	A
2027 Do Minimum										
Stream B-C	D7	0.0	5.62	0.02	A	D8	0.0	6.55	0.01	A
Stream B-A		0.1	11.37	0.06	B		0.1	11.03	0.07	B
Stream C-AB		0.0	8.45	0.01	A		0.0	7.53	0.04	A
2027 Do Something										
Stream B-C	D9	0.0	6.19	0.04	A	D10	0.0	6.70	0.03	A
Stream B-A		0.4	14.55	0.27	B		0.3	13.77	0.21	B
Stream C-AB		0.0	7.75	0.02	A		0.1	7.74	0.06	A
2032 Do Minimum										
Stream B-C	D11	0.0	5.66	0.02	A	D12	0.0	6.67	0.01	A
Stream B-A		0.1	11.77	0.06	B		0.1	11.49	0.08	B
Stream C-AB		0.0	8.48	0.01	A		0.0	7.63	0.04	A
2032 Do Something (FULL)										
Stream B-C	D13	0.0	6.30	0.04	A	D14	0.0	6.80	0.02	A
Stream B-A		0.4	15.87	0.30	C		0.3	14.60	0.22	B
Stream C-AB		0.0	7.83	0.02	A		0.1	7.78	0.06	A
2019 Calibration										
Stream B-C	D15	0.0	5.52	0.02	A	D16	0.0	6.60	0.01	A
Stream B-A		0.1	11.08	0.05	B		0.1	10.74	0.07	B
Stream C-AB		0.0	8.32	0.01	A		0.0	7.66	0.04	A

There are warnings associated with one or more model runs - see the 'Data Errors and Warnings' tables for each Analysis or Demand Set.

Values shown are the highest values encountered over all time segments. Delay is the maximum value of average delay per arriving vehicle.

File summary

File Description

Title	(untitled)
Location	
Site number	
Date	18/05/2016
Version	
Status	(new file)
Identifier	
Client	
Jobnumber	
Enumerator	DESKTOP-MD9GBJC\Fiona
Description	

Units

Distance units	Speed units	Traffic units input	Traffic units results	Flow units	Average delay units	Total delay units	Rate of delay units
m	kph	Veh	Veh	perHour	s	-Min	perMin

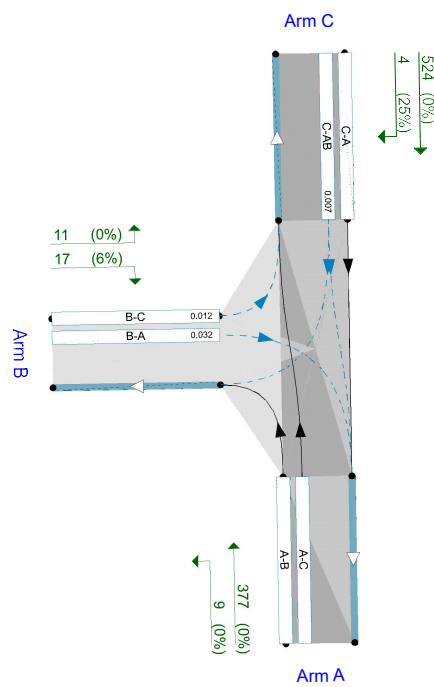

Flows show original traffic demand (veh/h).
Streams (downstream end) show RFC (1)

The junction diagram reflects the last run of Junctions.

Analysis Options

Calculate Queue Percentiles	Calculate residual capacity	RFC Threshold	Average Delay threshold (s)	Queue threshold (PCU)
✓		0.85	36.00	20.00

Demand Set Summary

ID	Scenario name	Time Period name	Traffic profile type	Start time (HH:mm)	Finish time (HH:mm)	Time segment length (min)
D1	2022 Do Minimum	AM	ONE HOUR	07:45	09:15	15
D2	2022 Do Minimum	PM	ONE HOUR	16:45	18:15	15
D3	2022 Do Something	AM	ONE HOUR	07:45	09:15	15
D4	2022 Do Something	PM	ONE HOUR	16:45	18:15	15
D5	2022 Do Something (FULL)	AM	ONE HOUR	07:45	09:15	15
D6	2022 Do Something (FULL)	PM	ONE HOUR	16:45	18:15	15
D7	2027 Do Minimum	AM	ONE HOUR	07:45	09:15	15
D8	2027 Do Minimum	PM	ONE HOUR	16:45	18:15	15
D9	2027 Do Something	AM	ONE HOUR	07:45	09:15	15
D10	2027 Do Something	PM	ONE HOUR	16:45	18:15	15
D11	2032 Do Minimum	AM	ONE HOUR	07:45	09:15	15
D12	2032 Do Minimum	PM	ONE HOUR	16:45	18:15	15
D13	2032 Do Something (FULL)	AM	ONE HOUR	07:45	09:15	15
D14	2032 Do Something (FULL)	PM	ONE HOUR	16:45	18:15	15
D15	2019 Calibration	AM	ONE HOUR	07:45	09:15	15
D16	2019 Calibration	PM	ONE HOUR	16:45	18:15	15

Analysis Set Details

ID	Network flow scaling factor (%)
A1	100.000

2022 Do Minimum, AM

Data Errors and Warnings

Severity	Area	Item	Description
Warning	Queue variations	Analysis Options	Queue percentiles may be unreliable if the mean queue in any time segment is very low or very high.

Junction Network

Junctions

Junction	Name	Junction type	Major road direction	Use circulating lanes	Junction Delay (s)	Junction LOS
1	Mill Lane/Delph Lane	T-Junction	Two-way		0.32	A

Junction Network Options

Driving side	Lighting
Left	Normal/unknown

Arms

Arms

Arm	Name	Description	Arm type
A	Mill Lane S		Major
B	Mill Lane/Site		Minor
C	Delph Lane		Major

Major Arm Geometry

Arm	Width of carriageway (m)	Has kerbed central reserve	Has right turn bay	Visibility for right turn (m)	Blocks?	Blocking queue (PCU)
C	7.30			80.0	✓	1.00

Geometries for Arm C are measured opposite Arm B. Geometries for Arm A (if relevant) are measured opposite Arm D.

Minor Arm Geometry

Arm	Minor arm type	Lane Width (Left) (m)	Lane Width (Right) (m)	Visibility to left (m)	Visibility to right (m)
B	Two lanes	5.00	3.80	42	56

Slope / Intercept / Capacity

Priority Intersection Slopes and Intercepts

Stream	Intercept (Veh/hr)	Slope for A-B	Slope for A-C	Slope for C-A	Slope for C-B
B-A	560	0.096	0.243	0.153	0.348
B-C	791	0.114	0.289	-	-
C-B	620	0.227	0.227	-	-

The slopes and intercepts shown above do NOT include any corrections or adjustments.

Streams may be combined, in which case capacity will be adjusted.

Values are shown for the first time segment only; they may differ for subsequent time segments.

Traffic Demand

Demand Set Details

ID	Scenario name	Time Period name	Traffic profile type	Start time (HH:mm)	Finish time (HH:mm)	Time segment length (min)
D1	2022 Do Minimum	AM	ONE HOUR	07:45	09:15	15

Vehicle mix source	PCU Factor for a HV (PCU)
HV Percentages	2.00

Demand overview (Traffic)

Arm	Linked arm	Use O-D data	Average Demand (Veh/hr)	Scaling Factor (%)
A		✓	386	100.000
B		✓	28	100.000
C		✓	528	100.000

Origin-Destination Data

Demand (Veh/hr)

		To		
		A	B	C
From	A	0	9	377
	B	17	0	11
	C	524	4	0

Vehicle Mix

Heavy Vehicle Percentages

		To		
		A	B	C
From	A	0	0	0
	B	6	0	0
	C	0	25	0

Results

Results Summary for whole modelled period

Stream	Max RFC	Max Delay (s)	Max Queue (Veh)	Max 95th percentile Queue (Veh)	Max LOS
B-C	0.02	5.55	0.0	0.5	A
B-A	0.05	10.96	0.1	0.5	B
C-AB	0.01	8.38	0.0	0.5	A
C-A					
A-B					
A-C					

Main Results for each time segment

07:45 - 08:00

Stream	Total Demand (Veh/hr)	Capacity (Veh/hr)	RFC	Throughput (Veh/hr)	End queue (Veh)	Delay (s)	Unsignalised level of service
B-C	8	703	0.012	8	0.0	5.183	A
B-A	13	405	0.032	13	0.0	9.181	A
C-AB	3	451	0.007	3	0.0	8.040	A
C-A	394			394			
A-B	7			7			
A-C	284			284			

08:00 - 08:15

Stream	Total Demand (Veh/hr)	Capacity (Veh/hr)	RFC	Throughput (Veh/hr)	End queue (Veh)	Delay (s)	Unsignalised level of service
B-C	10	685	0.014	10	0.0	5.330	A
B-A	15	381	0.040	15	0.0	9.852	A
C-AB	4	444	0.008	4	0.0	8.185	A
C-A	471			471			
A-B	8			8			
A-C	339			339			

08:15 - 08:30

Stream	Total Demand (Veh/hr)	Capacity (Veh/hr)	RFC	Throughput (Veh/hr)	End queue (Veh)	Delay (s)	Unsignalised level of service
B-C	12	661	0.018	12	0.0	5.548	A
B-A	19	347	0.054	19	0.1	10.954	B
C-AB	5	435	0.011	5	0.0	8.378	A
C-A	577			577			
A-B	10			10			
A-C	415			415			

08:30 - 08:45

Stream	Total Demand (Veh/hr)	Capacity (Veh/hr)	RFC	Throughput (Veh/hr)	End queue (Veh)	Delay (s)	Unsignalised level of service
B-C	12	661	0.018	12	0.0	5.548	A
B-A	19	347	0.054	19	0.1	10.955	B
C-AB	5	434	0.011	5	0.0	8.380	A
C-A	577			577			
A-B	10			10			
A-C	415			415			

08:45 - 09:00

Stream	Total Demand (Veh/hr)	Capacity (Veh/hr)	RFC	Throughput (Veh/hr)	End queue (Veh)	Delay (s)	Unsignalised level of service
B-C	10	685	0.014	10	0.0	5.332	A
B-A	15	381	0.040	15	0.0	9.859	A
C-AB	4	443	0.008	4	0.0	8.187	A
C-A	471			471			
A-B	8			8			
A-C	339			339			

09:00 - 09:15

Stream	Total Demand (Veh/hr)	Capacity (Veh/hr)	RFC	Throughput (Veh/hr)	End queue (Veh)	Delay (s)	Unsignalised level of service
B-C	8	703	0.012	8	0.0	5.186	A
B-A	13	405	0.032	13	0.0	9.190	A
C-AB	3	450	0.007	3	0.0	8.040	A
C-A	394			394			
A-B	7			7			
A-C	284			284			

Queue Variation Results for each time segment**07:45 - 08:00**

Stream	Mean (Veh)	Q05 (Veh)	Q50 (Veh)	Q90 (Veh)	Q95 (Veh)	Percentile message	Marker message	Probability of reaching or exceeding marker	Probability of exactly reaching marker
B-C	0.01	0.00	0.00	0.01	0.01			N/A	N/A
B-A	0.03	0.00	0.00	0.03	0.03			N/A	N/A
C-AB	0.01	0.00	0.00	0.01	0.01			N/A	N/A

08:00 - 08:15

Stream	Mean (Veh)	Q05 (Veh)	Q50 (Veh)	Q90 (Veh)	Q95 (Veh)	Percentile message	Marker message	Probability of reaching or exceeding marker	Probability of exactly reaching marker
B-C	0.01	0.01	0.25	0.45	0.48			N/A	N/A
B-A	0.04	0.03	0.25	0.45	0.48			N/A	N/A
C-AB	0.01	0.01	0.25	0.45	0.48			N/A	N/A

08:15 - 08:30

Stream	Mean (Veh)	Q05 (Veh)	Q50 (Veh)	Q90 (Veh)	Q95 (Veh)	Percentile message	Marker message	Probability of reaching or exceeding marker	Probability of exactly reaching marker
B-C	0.02	0.00	0.00	0.02	0.02			N/A	N/A
B-A	0.06	0.03	0.26	0.46	0.49			N/A	N/A
C-AB	0.01	0.00	0.00	0.01	0.01			N/A	N/A

08:30 - 08:45

Stream	Mean (Veh)	Q05 (Veh)	Q50 (Veh)	Q90 (Veh)	Q95 (Veh)	Percentile message	Marker message	Probability of reaching or exceeding marker	Probability of exactly reaching marker
B-C	0.02	0.00	0.00	0.02	0.02			N/A	N/A
B-A	0.06	0.00	0.00	0.06	0.06			N/A	N/A
C-AB	0.01	0.00	0.00	0.01	0.01			N/A	N/A

08:45 - 09:00

Stream	Mean (Veh)	Q05 (Veh)	Q50 (Veh)	Q90 (Veh)	Q95 (Veh)	Percentile message	Marker message	Probability of reaching or exceeding marker	Probability of exactly reaching marker
B-C	0.01	0.00	0.00	0.01	0.01			N/A	N/A
B-A	0.04	0.00	0.00	0.04	0.04			N/A	N/A
C-AB	0.01	0.00	0.00	0.01	0.01			N/A	N/A

09:00 - 09:15

Stream	Mean (Veh)	Q05 (Veh)	Q50 (Veh)	Q90 (Veh)	Q95 (Veh)	Percentile message	Marker message	Probability of reaching or exceeding marker	Probability of exactly reaching marker
B-C	0.01	0.00	0.00	0.01	0.01			N/A	N/A
B-A	0.03	0.00	0.00	0.03	0.03			N/A	N/A
C-AB	0.01	0.00	0.00	0.01	0.01			N/A	N/A

2022 Do Minimum, PM

Data Errors and Warnings

Severity	Area	Item	Description
Warning	Queue variations	Analysis Options	Queue percentiles may be unreliable if the mean queue in any time segment is very low or very high.

Junction Network

Junctions

Junction	Name	Junction type	Major road direction	Use circulating lanes	Junction Delay (s)	Junction LOS
1	Mill Lane/Delph Lane	T-Junction	Two-way		0.49	A

Junction Network Options

Driving side	Lighting
Left	Normal/unknown

Traffic Demand

Demand Set Details

ID	Scenario name	Time Period name	Traffic profile type	Start time (HH:mm)	Finish time (HH:mm)	Time segment length (min)
D2	2022 Do Minimum	PM	ONE HOUR	16:45	18:15	15

Vehicle mix source	PCU Factor for a HV (PCU)
HV Percentages	2.00

Demand overview (Traffic)

Arm	Linked arm	Use O-D data	Average Demand (Veh/hr)	Scaling Factor (%)
A		✓	433	100.000
B		✓	31	100.000
C		✓	449	100.000

Origin-Destination Data

Demand (Veh/hr)

		To		
		A	B	C
From	A	0	38	395
	B	24	0	7
	C	431	18	0

Vehicle Mix

Heavy Vehicle Percentages

		To		
		A	B	C
From	A	0	0	0
	B	0	0	14
	C	1	6	0

Results

Results Summary for whole modelled period

Stream	Max RFC	Max Delay (s)	Max Queue (Veh)	Max 95th percentile Queue (Veh)	Max LOS
B-C	0.01	6.41	0.0	0.5	A
B-A	0.07	10.48	0.1	0.5	B
C-AB	0.04	7.41	0.0	0.5	A
C-A					
A-B					
A-C					

Main Results for each time segment

16:45 - 17:00

Stream	Total Demand (Veh/hr)	Capacity (Veh/hr)	RFC	Throughput (Veh/hr)	End queue (Veh)	Delay (s)	Unsignalised level of service
B-C	5	609	0.009	5	0.0	5.959	A
B-A	18	430	0.042	18	0.0	8.730	A
C-AB	14	526	0.026	14	0.0	7.026	A
C-A	324			324			
A-B	29			29			
A-C	297			297			

17:00 - 17:15

Stream	Total Demand (Veh/hr)	Capacity (Veh/hr)	RFC	Throughput (Veh/hr)	End queue (Veh)	Delay (s)	Unsignalised level of service
B-C	6	592	0.011	6	0.0	6.141	A
B-A	22	405	0.053	22	0.1	9.393	A
C-AB	17	517	0.032	17	0.0	7.193	A
C-A	387			387			
A-B	34			34			
A-C	355			355			

17:15 - 17:30

Stream	Total Demand (Veh/hr)	Capacity (Veh/hr)	RFC	Throughput (Veh/hr)	End queue (Veh)	Delay (s)	Unsignalised level of service
B-C	8	569	0.014	8	0.0	6.412	A
B-A	26	370	0.071	26	0.1	10.480	B
C-AB	21	507	0.041	21	0.0	7.410	A
C-A	474			474			
A-B	42			42			
A-C	435			435			

17:30 - 17:45

Stream	Total Demand (Veh/hr)	Capacity (Veh/hr)	RFC	Throughput (Veh/hr)	End queue (Veh)	Delay (s)	Unsignalised level of service
B-C	8	569	0.014	8	0.0	6.412	A
B-A	26	370	0.071	26	0.1	10.485	B
C-AB	21	507	0.041	21	0.0	7.410	A
C-A	474			474			
A-B	42			42			
A-C	435			435			

17:45 - 18:00

Stream	Total Demand (Veh/hr)	Capacity (Veh/hr)	RFC	Throughput (Veh/hr)	End queue (Veh)	Delay (s)	Unsignalised level of service
B-C	6	592	0.011	6	0.0	6.141	A
B-A	22	405	0.053	22	0.1	9.399	A
C-AB	17	517	0.032	17	0.0	7.197	A
C-A	387			387			
A-B	34			34			
A-C	355			355			

18:00 - 18:15

Stream	Total Demand (Veh/hr)	Capacity (Veh/hr)	RFC	Throughput (Veh/hr)	End queue (Veh)	Delay (s)	Unsignalised level of service
B-C	5	609	0.009	5	0.0	5.963	A
B-A	18	430	0.042	18	0.0	8.742	A
C-AB	14	526	0.026	14	0.0	7.029	A
C-A	324			324			
A-B	29			29			
A-C	297			297			

Queue Variation Results for each time segment**16:45 - 17:00**

Stream	Mean (Veh)	Q05 (Veh)	Q50 (Veh)	Q90 (Veh)	Q95 (Veh)	Percentile message	Marker message	Probability of reaching or exceeding marker	Probability of exactly reaching marker
B-C	0.01	0.00	0.00	0.01	0.01			N/A	N/A
B-A	0.04	0.00	0.00	0.04	0.04			N/A	N/A
C-AB	0.03	0.00	0.00	0.03	0.03			N/A	N/A

17:00 - 17:15

Stream	Mean (Veh)	Q05 (Veh)	Q50 (Veh)	Q90 (Veh)	Q95 (Veh)	Percentile message	Marker message	Probability of reaching or exceeding marker	Probability of exactly reaching marker
B-C	0.01	0.01	0.25	0.45	0.48			N/A	N/A
B-A	0.06	0.03	0.25	0.45	0.48			N/A	N/A
C-AB	0.03	0.03	0.25	0.45	0.48			N/A	N/A

17:15 - 17:30

Stream	Mean (Veh)	Q05 (Veh)	Q50 (Veh)	Q90 (Veh)	Q95 (Veh)	Percentile message	Marker message	Probability of reaching or exceeding marker	Probability of exactly reaching marker
B-C	0.01	0.00	0.00	0.01	0.01			N/A	N/A
B-A	0.08	0.03	0.26	0.47	0.49			N/A	N/A
C-AB	0.04	0.03	0.25	0.46	0.48			N/A	N/A

17:30 - 17:45

Stream	Mean (Veh)	Q05 (Veh)	Q50 (Veh)	Q90 (Veh)	Q95 (Veh)	Percentile message	Marker message	Probability of reaching or exceeding marker	Probability of exactly reaching marker
B-C	0.01	0.00	0.00	0.01	0.01			N/A	N/A
B-A	0.08	0.00	0.00	0.08	0.08			N/A	N/A
C-AB	0.04	0.00	0.00	0.04	0.04			N/A	N/A

17:45 - 18:00

Stream	Mean (Veh)	Q05 (Veh)	Q50 (Veh)	Q90 (Veh)	Q95 (Veh)	Percentile message	Marker message	Probability of reaching or exceeding marker	Probability of exactly reaching marker
B-C	0.01	0.00	0.00	0.01	0.01			N/A	N/A
B-A	0.06	0.00	0.00	0.06	0.06			N/A	N/A
C-AB	0.03	0.00	0.00	0.03	0.03			N/A	N/A

18:00 - 18:15

Stream	Mean (Veh)	Q05 (Veh)	Q50 (Veh)	Q90 (Veh)	Q95 (Veh)	Percentile message	Marker message	Probability of reaching or exceeding marker	Probability of exactly reaching marker
B-C	0.01	0.00	0.00	0.01	0.01			N/A	N/A
B-A	0.04	0.00	0.00	0.04	0.04			N/A	N/A
C-AB	0.03	0.00	0.00	0.03	0.03			N/A	N/A

2022 Do Something, AM

Data Errors and Warnings

Severity	Area	Item	Description
Warning	Queue variations	Analysis Options	Queue percentiles may be unreliable if the mean queue in any time segment is very low or very high.

Junction Network

Junctions

Junction	Name	Junction type	Major road direction	Use circulating lanes	Junction Delay (s)	Junction LOS
1	Mill Lane/Delph Lane	T-Junction	Two-way		0.66	A

Junction Network Options

Driving side	Lighting
Left	Normal/unknown

Traffic Demand

Demand Set Details

ID	Scenario name	Time Period name	Traffic profile type	Start time (HH:mm)	Finish time (HH:mm)	Time segment length (min)
D3	2022 Do Something	AM	ONE HOUR	07:45	09:15	15

Vehicle mix source	PCU Factor for a HV (PCU)
HV Percentages	2.00

Demand overview (Traffic)

Arm	Linked arm	Use O-D data	Average Demand (Veh/hr)	Scaling Factor (%)
A		✓	400	100.000
B		✓	59	100.000
C		✓	531	100.000

Origin-Destination Data

Demand (Veh/hr)

		To		
		A	B	C
From	A	0	21	379
	B	43	0	16
	C	525	6	0

Vehicle Mix

Heavy Vehicle Percentages

		To		
		A	B	C
From	A	0	0	0
	B	2	0	0
	C	0	16	0

Results

Results Summary for whole modelled period

Stream	Max RFC	Max Delay (s)	Max Queue (Veh)	Max 95th percentile Queue (Veh)	Max LOS
B-C	0.03	5.73	0.0	0.5	A
B-A	0.13	11.58	0.2	0.5	B
C-AB	0.01	7.88	0.0	0.5	A
C-A					
A-B					
A-C					

Main Results for each time segment

07:45 - 08:00

Stream	Total Demand (Veh/hr)	Capacity (Veh/hr)	RFC	Throughput (Veh/hr)	End queue (Veh)	Delay (s)	Unsignalised level of service
B-C	12	693	0.017	12	0.0	5.284	A
B-A	32	419	0.077	32	0.1	9.303	A
C-AB	5	483	0.009	5	0.0	7.523	A
C-A	395			395			
A-B	16			16			
A-C	285			285			

08:00 - 08:15

Stream	Total Demand (Veh/hr)	Capacity (Veh/hr)	RFC	Throughput (Veh/hr)	End queue (Veh)	Delay (s)	Unsignalised level of service
B-C	14	673	0.021	14	0.0	5.462	A
B-A	39	393	0.098	39	0.1	10.146	B
C-AB	6	475	0.012	6	0.0	7.673	A
C-A	472			472			
A-B	19			19			
A-C	341			341			

08:15 - 08:30

Stream	Total Demand (Veh/hr)	Capacity (Veh/hr)	RFC	Throughput (Veh/hr)	End queue (Veh)	Delay (s)	Unsignalised level of service
B-C	18	646	0.027	18	0.0	5.732	A
B-A	47	358	0.132	47	0.2	11.567	B
C-AB	7	464	0.015	7	0.0	7.876	A
C-A	578			578			
A-B	23			23			
A-C	417			417			

08:30 - 08:45

Stream	Total Demand (Veh/hr)	Capacity (Veh/hr)	RFC	Throughput (Veh/hr)	End queue (Veh)	Delay (s)	Unsignalised level of service
B-C	18	646	0.027	18	0.0	5.732	A
B-A	47	358	0.132	47	0.2	11.579	B
C-AB	7	464	0.015	7	0.0	7.876	A
C-A	578			578			
A-B	23			23			
A-C	417			417			

08:45 - 09:00

Stream	Total Demand (Veh/hr)	Capacity (Veh/hr)	RFC	Throughput (Veh/hr)	End queue (Veh)	Delay (s)	Unsignalised level of service
B-C	14	673	0.021	14	0.0	5.465	A
B-A	39	393	0.098	39	0.1	10.161	B
C-AB	6	474	0.012	6	0.0	7.674	A
C-A	472			472			
A-B	19			19			
A-C	341			341			

09:00 - 09:15

Stream	Total Demand (Veh/hr)	Capacity (Veh/hr)	RFC	Throughput (Veh/hr)	End queue (Veh)	Delay (s)	Unsignalised level of service
B-C	12	693	0.017	12	0.0	5.286	A
B-A	32	419	0.077	32	0.1	9.323	A
C-AB	5	483	0.010	5	0.0	7.527	A
C-A	395			395			
A-B	16			16			
A-C	285			285			

Queue Variation Results for each time segment**07:45 - 08:00**

Stream	Mean (Veh)	Q05 (Veh)	Q50 (Veh)	Q90 (Veh)	Q95 (Veh)	Percentile message	Marker message	Probability of reaching or exceeding marker	Probability of exactly reaching marker
B-C	0.02	0.00	0.00	0.02	0.02			N/A	N/A
B-A	0.08	0.00	0.00	0.08	0.08			N/A	N/A
C-AB	0.01	0.00	0.00	0.01	0.01			N/A	N/A

08:00 - 08:15

Stream	Mean (Veh)	Q05 (Veh)	Q50 (Veh)	Q90 (Veh)	Q95 (Veh)	Percentile message	Marker message	Probability of reaching or exceeding marker	Probability of exactly reaching marker
B-C	0.02	0.02	0.25	0.45	0.48			N/A	N/A
B-A	0.11	0.00	0.00	0.11	0.11			N/A	N/A
C-AB	0.01	0.01	0.25	0.45	0.48			N/A	N/A

08:15 - 08:30

Stream	Mean (Veh)	Q05 (Veh)	Q50 (Veh)	Q90 (Veh)	Q95 (Veh)	Percentile message	Marker message	Probability of reaching or exceeding marker	Probability of exactly reaching marker
B-C	0.03	0.00	0.00	0.03	0.03			N/A	N/A
B-A	0.15	0.03	0.26	0.47	0.49			N/A	N/A
C-AB	0.02	0.00	0.00	0.02	0.02			N/A	N/A

08:30 - 08:45

Stream	Mean (Veh)	Q05 (Veh)	Q50 (Veh)	Q90 (Veh)	Q95 (Veh)	Percentile message	Marker message	Probability of reaching or exceeding marker	Probability of exactly reaching marker
B-C	0.03	0.00	0.00	0.03	0.03			N/A	N/A
B-A	0.15	0.03	0.25	0.45	0.48			N/A	N/A
C-AB	0.02	0.00	0.00	0.02	0.02			N/A	N/A

08:45 - 09:00

Stream	Mean (Veh)	Q05 (Veh)	Q50 (Veh)	Q90 (Veh)	Q95 (Veh)	Percentile message	Marker message	Probability of reaching or exceeding marker	Probability of exactly reaching marker
B-C	0.02	0.00	0.00	0.02	0.02			N/A	N/A
B-A	0.11	0.00	0.00	0.11	0.11			N/A	N/A
C-AB	0.01	0.00	0.00	0.01	0.01			N/A	N/A

09:00 - 09:15

Stream	Mean (Veh)	Q05 (Veh)	Q50 (Veh)	Q90 (Veh)	Q95 (Veh)	Percentile message	Marker message	Probability of reaching or exceeding marker	Probability of exactly reaching marker
B-C	0.02	0.00	0.00	0.02	0.02			N/A	N/A
B-A	0.08	0.00	0.00	0.08	0.08			N/A	N/A
C-AB	0.01	0.00	0.00	0.01	0.01			N/A	N/A

2022 Do Something, PM

Data Errors and Warnings

Severity	Area	Item	Description
Warning	Queue variations	Analysis Options	Queue percentiles may be unreliable if the mean queue in any time segment is very low or very high.

Junction Network

Junctions

Junction	Name	Junction type	Major road direction	Use circulating lanes	Junction Delay (s)	Junction LOS
1	Mill Lane/Delph Lane	T-Junction	Two-way		0.70	A

Junction Network Options

Driving side	Lighting
Left	Normal/unknown

Traffic Demand

Demand Set Details

ID	Scenario name	Time Period name	Traffic profile type	Start time (HH:mm)	Finish time (HH:mm)	Time segment length (min)
D4	2022 Do Something	PM	ONE HOUR	16:45	18:15	15

Vehicle mix source	PCU Factor for a HV (PCU)
HV Percentages	2.00

Demand overview (Traffic)

Arm	Linked arm	Use O-D data	Average Demand (Veh/hr)	Scaling Factor (%)
A		✓	461	100.000
B		✓	49	100.000
C		✓	456	100.000

Origin-Destination Data

Demand (Veh/hr)

		To		
		A	B	C
From	A	0	65	396
	B	39	0	10
	C	435	21	0

Vehicle Mix

Heavy Vehicle Percentages

		To		
		A	B	C
From	A	0	0	0
	B	0	0	10
	C	1	5	0

Results

Results Summary for whole modelled period

Stream	Max RFC	Max Delay (s)	Max Queue (Veh)	Max 95th percentile Queue (Veh)	Max LOS
B-C	0.02	6.33	0.0	0.5	A
B-A	0.12	11.18	0.1	0.5	B
C-AB	0.05	7.45	0.1	0.5	A
C-A					
A-B					
A-C					

Main Results for each time segment

16:45 - 17:00

Stream	Total Demand (Veh/hr)	Capacity (Veh/hr)	RFC	Throughput (Veh/hr)	End queue (Veh)	Delay (s)	Unsignalised level of service
B-C	8	625	0.012	7	0.0	5.831	A
B-A	29	427	0.069	29	0.1	9.047	A
C-AB	16	528	0.031	16	0.0	7.034	A
C-A	327			327			
A-B	49			49			
A-C	298			298			

17:00 - 17:15

Stream	Total Demand (Veh/hr)	Capacity (Veh/hr)	RFC	Throughput (Veh/hr)	End queue (Veh)	Delay (s)	Unsignalised level of service
B-C	9	606	0.015	9	0.0	6.030	A
B-A	35	401	0.088	35	0.1	9.841	A
C-AB	20	519	0.038	19	0.0	7.214	A
C-A	390			390			
A-B	58			58			
A-C	356			356			

17:15 - 17:30

Stream	Total Demand (Veh/hr)	Capacity (Veh/hr)	RFC	Throughput (Veh/hr)	End queue (Veh)	Delay (s)	Unsignalised level of service
B-C	11	579	0.019	11	0.0	6.332	A
B-A	43	365	0.118	43	0.1	11.175	B
C-AB	24	508	0.048	24	0.1	7.447	A
C-A	478			478			
A-B	72			72			
A-C	436			436			

17:30 - 17:45

Stream	Total Demand (Veh/hr)	Capacity (Veh/hr)	RFC	Throughput (Veh/hr)	End queue (Veh)	Delay (s)	Unsignalised level of service
B-C	11	579	0.019	11	0.0	6.333	A
B-A	43	365	0.118	43	0.1	11.184	B
C-AB	24	508	0.048	24	0.1	7.447	A
C-A	478			478			
A-B	72			72			
A-C	436			436			

17:45 - 18:00

Stream	Total Demand (Veh/hr)	Capacity (Veh/hr)	RFC	Throughput (Veh/hr)	End queue (Veh)	Delay (s)	Unsignalised level of service
B-C	9	606	0.015	9	0.0	6.033	A
B-A	35	401	0.088	35	0.1	9.855	A
C-AB	20	518	0.038	20	0.0	7.215	A
C-A	390			390			
A-B	58			58			
A-C	356			356			

18:00 - 18:15

Stream	Total Demand (Veh/hr)	Capacity (Veh/hr)	RFC	Throughput (Veh/hr)	End queue (Veh)	Delay (s)	Unsignalised level of service
B-C	8	625	0.012	8	0.0	5.832	A
B-A	29	427	0.069	29	0.1	9.067	A
C-AB	16	528	0.031	16	0.0	7.041	A
C-A	327			327			
A-B	49			49			
A-C	298			298			

Queue Variation Results for each time segment

16:45 - 17:00

Stream	Mean (Veh)	Q05 (Veh)	Q50 (Veh)	Q90 (Veh)	Q95 (Veh)	Percentile message	Marker message	Probability of reaching or exceeding marker	Probability of exactly reaching marker
B-C	0.01	0.00	0.00	0.01	0.01			N/A	N/A
B-A	0.07	0.00	0.00	0.07	0.07			N/A	N/A
C-AB	0.03	0.00	0.00	0.03	0.03			N/A	N/A

17:00 - 17:15

Stream	Mean (Veh)	Q05 (Veh)	Q50 (Veh)	Q90 (Veh)	Q95 (Veh)	Percentile message	Marker message	Probability of reaching or exceeding marker	Probability of exactly reaching marker
B-C	0.01	0.01	0.25	0.45	0.48			N/A	N/A
B-A	0.09	0.03	0.25	0.45	0.48			N/A	N/A
C-AB	0.04	0.03	0.25	0.45	0.48			N/A	N/A

17:15 - 17:30

Stream	Mean (Veh)	Q05 (Veh)	Q50 (Veh)	Q90 (Veh)	Q95 (Veh)	Percentile message	Marker message	Probability of reaching or exceeding marker	Probability of exactly reaching marker
B-C	0.02	0.00	0.00	0.02	0.02			N/A	N/A
B-A	0.13	0.03	0.26	0.47	0.49			N/A	N/A
C-AB	0.05	0.03	0.26	0.46	0.49			N/A	N/A

17:30 - 17:45

Stream	Mean (Veh)	Q05 (Veh)	Q50 (Veh)	Q90 (Veh)	Q95 (Veh)	Percentile message	Marker message	Probability of reaching or exceeding marker	Probability of exactly reaching marker
B-C	0.02	0.00	0.00	0.02	0.02			N/A	N/A
B-A	0.13	0.03	0.25	0.45	0.48			N/A	N/A
C-AB	0.05	0.00	0.00	0.05	0.05			N/A	N/A

17:45 - 18:00

Stream	Mean (Veh)	Q05 (Veh)	Q50 (Veh)	Q90 (Veh)	Q95 (Veh)	Percentile message	Marker message	Probability of reaching or exceeding marker	Probability of exactly reaching marker
B-C	0.02	0.00	0.00	0.02	0.02			N/A	N/A
B-A	0.10	0.00	0.00	0.10	0.10			N/A	N/A
C-AB	0.04	0.00	0.00	0.04	0.04			N/A	N/A

18:00 - 18:15

Stream	Mean (Veh)	Q05 (Veh)	Q50 (Veh)	Q90 (Veh)	Q95 (Veh)	Percentile message	Marker message	Probability of reaching or exceeding marker	Probability of exactly reaching marker
B-C	0.01	0.00	0.00	0.01	0.01			N/A	N/A
B-A	0.07	0.00	0.00	0.07	0.07			N/A	N/A
C-AB	0.03	0.00	0.00	0.03	0.03			N/A	N/A

2022 Do Something (FULL), AM

Data Errors and Warnings

Severity	Area	Item	Description
Warning	Queue variations	Analysis Options	Queue percentiles may be unreliable if the mean queue in any time segment is very low or very high.

Junction Network

Junctions

Junction	Name	Junction type	Major road direction	Use circulating lanes	Junction Delay (s)	Junction LOS
1	Mill Lane/Delph Lane	T-Junction	Two-way		1.28	A

Junction Network Options

Driving side	Lighting
Left	Normal/unknown

Traffic Demand

Demand Set Details

ID	Scenario name	Time Period name	Traffic profile type	Start time (HH:mm)	Finish time (HH:mm)	Time segment length (min)
D5	2022 Do Something (FULL)	AM	ONE HOUR	07:45	09:15	15

Vehicle mix source	PCU Factor for a HV (PCU)
HV Percentages	2.00

Demand overview (Traffic)

Arm	Linked arm	Use O-D data	Average Demand (Veh/hr)	Scaling Factor (%)
A		✓	478	100.000
B		✓	108	100.000
C		✓	556	100.000

Origin-Destination Data

Demand (Veh/hr)

		To		
		A	B	C
From	A	0	38	440
	B	84	0	24
	C	547	9	0

Vehicle Mix

Heavy Vehicle Percentages

		To		
		A	B	C
From	A	0	0	0
	B	1	0	0
	C	0	11	0

Results

Results Summary for whole modelled period

Stream	Max RFC	Max Delay (s)	Max Queue (Veh)	Max 95th percentile Queue (Veh)	Max LOS
B-C	0.04	6.26	0.0	0.5	A
B-A	0.27	14.60	0.4	1.4	B
C-AB	0.02	7.82	0.0	0.5	A
C-A					
A-B					
A-C					

Main Results for each time segment

07:45 - 08:00

Stream	Total Demand (Veh/hr)	Capacity (Veh/hr)	RFC	Throughput (Veh/hr)	End queue (Veh)	Delay (s)	Unsignalised level of service
B-C	18	665	0.027	18	0.0	5.562	A
B-A	63	407	0.155	63	0.2	10.421	B
C-AB	7	494	0.014	7	0.0	7.388	A
C-A	412			412			
A-B	29			29			
A-C	331			331			

08:00 - 08:15

Stream	Total Demand (Veh/hr)	Capacity (Veh/hr)	RFC	Throughput (Veh/hr)	End queue (Veh)	Delay (s)	Unsignalised level of service
B-C	22	639	0.034	22	0.0	5.830	A
B-A	76	379	0.199	75	0.2	11.858	B
C-AB	8	484	0.017	8	0.0	7.572	A
C-A	492			492			
A-B	34			34			
A-C	396			396			

08:15 - 08:30

Stream	Total Demand (Veh/hr)	Capacity (Veh/hr)	RFC	Throughput (Veh/hr)	End queue (Veh)	Delay (s)	Unsignalised level of service
B-C	26	602	0.044	26	0.0	6.256	A
B-A	92	339	0.273	92	0.4	14.546	B
C-AB	10	471	0.022	10	0.0	7.820	A
C-A	602			602			
A-B	42			42			
A-C	484			484			

08:30 - 08:45

Stream	Total Demand (Veh/hr)	Capacity (Veh/hr)	RFC	Throughput (Veh/hr)	End queue (Veh)	Delay (s)	Unsignalised level of service
B-C	26	602	0.044	26	0.0	6.259	A
B-A	92	339	0.273	92	0.4	14.601	B
C-AB	10	471	0.022	10	0.0	7.822	A
C-A	602			602			
A-B	42			42			
A-C	484			484			

08:45 - 09:00

Stream	Total Demand (Veh/hr)	Capacity (Veh/hr)	RFC	Throughput (Veh/hr)	End queue (Veh)	Delay (s)	Unsignalised level of service
B-C	22	639	0.034	22	0.0	5.836	A
B-A	76	379	0.199	76	0.3	11.915	B
C-AB	8	483	0.017	8	0.0	7.572	A
C-A	492			492			
A-B	34			34			
A-C	396			396			

09:00 - 09:15

Stream	Total Demand (Veh/hr)	Capacity (Veh/hr)	RFC	Throughput (Veh/hr)	End queue (Veh)	Delay (s)	Unsignalised level of service
B-C	18	665	0.027	18	0.0	5.566	A
B-A	63	407	0.155	64	0.2	10.483	B
C-AB	7	494	0.014	7	0.0	7.391	A
C-A	412			412			
A-B	29			29			
A-C	331			331			

Queue Variation Results for each time segment**07:45 - 08:00**

Stream	Mean (Veh)	Q05 (Veh)	Q50 (Veh)	Q90 (Veh)	Q95 (Veh)	Percentile message	Marker message	Probability of reaching or exceeding marker	Probability of exactly reaching marker
B-C	0.03	0.00	0.00	0.03	0.03			N/A	N/A
B-A	0.18	0.00	0.00	0.18	0.18			N/A	N/A
C-AB	0.01	0.00	0.00	0.01	0.01			N/A	N/A

08:00 - 08:15

Stream	Mean (Veh)	Q05 (Veh)	Q50 (Veh)	Q90 (Veh)	Q95 (Veh)	Percentile message	Marker message	Probability of reaching or exceeding marker	Probability of exactly reaching marker
B-C	0.03	0.03	0.25	0.45	0.48			N/A	N/A
B-A	0.25	0.00	0.00	0.25	0.25			N/A	N/A
C-AB	0.02	0.02	0.25	0.45	0.48			N/A	N/A

08:15 - 08:30

Stream	Mean (Veh)	Q05 (Veh)	Q50 (Veh)	Q90 (Veh)	Q95 (Veh)	Percentile message	Marker message	Probability of reaching or exceeding marker	Probability of exactly reaching marker
B-C	0.05	0.03	0.25	0.46	0.48			N/A	N/A
B-A	0.37	0.03	0.26	0.46	0.49			N/A	N/A
C-AB	0.02	0.00	0.00	0.02	0.02			N/A	N/A

08:30 - 08:45

Stream	Mean (Veh)	Q05 (Veh)	Q50 (Veh)	Q90 (Veh)	Q95 (Veh)	Percentile message	Marker message	Probability of reaching or exceeding marker	Probability of exactly reaching marker
B-C	0.05	0.00	0.00	0.05	0.05			N/A	N/A
B-A	0.37	0.03	0.31	1.24	1.37			N/A	N/A
C-AB	0.02	0.00	0.00	0.02	0.02			N/A	N/A

08:45 - 09:00

Stream	Mean (Veh)	Q05 (Veh)	Q50 (Veh)	Q90 (Veh)	Q95 (Veh)	Percentile message	Marker message	Probability of reaching or exceeding marker	Probability of exactly reaching marker
B-C	0.04	0.00	0.00	0.04	0.04			N/A	N/A
B-A	0.25	0.00	0.00	0.25	0.25			N/A	N/A
C-AB	0.02	0.00	0.00	0.02	0.02			N/A	N/A

09:00 - 09:15

Stream	Mean (Veh)	Q05 (Veh)	Q50 (Veh)	Q90 (Veh)	Q95 (Veh)	Percentile message	Marker message	Probability of reaching or exceeding marker	Probability of exactly reaching marker
B-C	0.03	0.00	0.00	0.03	0.03			N/A	N/A
B-A	0.19	0.00	0.00	0.19	0.19			N/A	N/A
C-AB	0.01	0.00	0.00	0.01	0.01			N/A	N/A

2022 Do Something (FULL), PM

Data Errors and Warnings

Severity	Area	Item	Description
Warning	Queue variations	Analysis Options	Queue percentiles may be unreliable if the mean queue in any time segment is very low or very high.

Junction Network

Junctions

Junction	Name	Junction type	Major road direction	Use circulating lanes	Junction Delay (s)	Junction LOS
1	Mill Lane/Delph Lane	T-Junction	Two-way		1.02	A

Junction Network Options

Driving side	Lighting
Left	Normal/unknown

Traffic Demand

Demand Set Details

ID	Scenario name	Time Period name	Traffic profile type	Start time (HH:mm)	Finish time (HH:mm)	Time segment length (min)
D6	2022 Do Something (FULL)	PM	ONE HOUR	16:45	18:15	15

Vehicle mix source	PCU Factor for a HV (PCU)
HV Percentages	2.00

Demand overview (Traffic)

Arm	Linked arm	Use O-D data	Average Demand (Veh/hr)	Scaling Factor (%)
A		✓	522	100.000
B		✓	77	100.000
C		✓	510	100.000

Origin-Destination Data

Demand (Veh/hr)

		To		
		A	B	C
From	A	0	105	417
	B	64	0	13
	C	485	25	0

Vehicle Mix

Heavy Vehicle Percentages

		To		
		A	B	C
From	A	0	0	0
	B	0	0	8
	C	0	4	0

Results

Results Summary for whole modelled period

Stream	Max RFC	Max Delay (s)	Max Queue (Veh)	Max 95th percentile Queue (Veh)	Max LOS
B-C	0.03	6.52	0.0	0.5	A
B-A	0.20	13.08	0.3	1.2	B
C-AB	0.06	7.56	0.1	0.5	A
C-A					
A-B					
A-C					

Main Results for each time segment

16:45 - 17:00

Stream	Total Demand (Veh/hr)	Capacity (Veh/hr)	RFC	Throughput (Veh/hr)	End queue (Veh)	Delay (s)	Unsignalised level of service
B-C	10	621	0.016	10	0.0	5.884	A
B-A	48	414	0.116	48	0.1	9.823	A
C-AB	19	526	0.037	19	0.0	7.101	A
C-A	365			365			
A-B	79			79			
A-C	314			314			

17:00 - 17:15

Stream	Total Demand (Veh/hr)	Capacity (Veh/hr)	RFC	Throughput (Veh/hr)	End queue (Veh)	Delay (s)	Unsignalised level of service
B-C	12	599	0.020	12	0.0	6.131	A
B-A	58	385	0.149	57	0.2	10.978	B
C-AB	23	517	0.045	23	0.0	7.301	A
C-A	435			435			
A-B	94			94			
A-C	375			375			

17:15 - 17:30

Stream	Total Demand (Veh/hr)	Capacity (Veh/hr)	RFC	Throughput (Veh/hr)	End queue (Veh)	Delay (s)	Unsignalised level of service
B-C	14	567	0.025	14	0.0	6.517	A
B-A	70	346	0.204	70	0.3	13.050	B
C-AB	30	506	0.058	29	0.1	7.556	A
C-A	532			532			
A-B	116			116			
A-C	459			459			

17:30 - 17:45

Stream	Total Demand (Veh/hr)	Capacity (Veh/hr)	RFC	Throughput (Veh/hr)	End queue (Veh)	Delay (s)	Unsignalised level of service
B-C	14	567	0.025	14	0.0	6.518	A
B-A	70	346	0.204	70	0.3	13.079	B
C-AB	30	506	0.058	30	0.1	7.559	A
C-A	532			532			
A-B	116			116			
A-C	459			459			

17:45 - 18:00

Stream	Total Demand (Veh/hr)	Capacity (Veh/hr)	RFC	Throughput (Veh/hr)	End queue (Veh)	Delay (s)	Unsignalised level of service
B-C	12	599	0.020	12	0.0	6.136	A
B-A	58	385	0.149	58	0.2	11.010	B
C-AB	23	516	0.046	24	0.1	7.303	A
C-A	435			435			
A-B	94			94			
A-C	375			375			

18:00 - 18:15

Stream	Total Demand (Veh/hr)	Capacity (Veh/hr)	RFC	Throughput (Veh/hr)	End queue (Veh)	Delay (s)	Unsignalised level of service
B-C	10	621	0.016	10	0.0	5.889	A
B-A	48	414	0.117	48	0.1	9.861	A
C-AB	19	526	0.037	19	0.0	7.105	A
C-A	365			365			
A-B	79			79			
A-C	314			314			

Queue Variation Results for each time segment

16:45 - 17:00

Stream	Mean (Veh)	Q05 (Veh)	Q50 (Veh)	Q90 (Veh)	Q95 (Veh)	Percentile message	Marker message	Probability of reaching or exceeding marker	Probability of exactly reaching marker
B-C	0.02	0.00	0.00	0.02	0.02			N/A	N/A
B-A	0.13	0.00	0.00	0.13	0.13			N/A	N/A
C-AB	0.04	0.00	0.00	0.04	0.04			N/A	N/A

17:00 - 17:15

Stream	Mean (Veh)	Q05 (Veh)	Q50 (Veh)	Q90 (Veh)	Q95 (Veh)	Percentile message	Marker message	Probability of reaching or exceeding marker	Probability of exactly reaching marker
B-C	0.02	0.02	0.25	0.45	0.48			N/A	N/A
B-A	0.17	0.00	0.00	0.17	0.17			N/A	N/A
C-AB	0.05	0.03	0.25	0.45	0.48			N/A	N/A

17:15 - 17:30

Stream	Mean (Veh)	Q05 (Veh)	Q50 (Veh)	Q90 (Veh)	Q95 (Veh)	Percentile message	Marker message	Probability of reaching or exceeding marker	Probability of exactly reaching marker
B-C	0.03	0.00	0.00	0.03	0.03			N/A	N/A
B-A	0.25	0.03	0.26	0.46	0.49			N/A	N/A
C-AB	0.07	0.03	0.26	0.47	0.49			N/A	N/A

17:30 - 17:45

Stream	Mean (Veh)	Q05 (Veh)	Q50 (Veh)	Q90 (Veh)	Q95 (Veh)	Percentile message	Marker message	Probability of reaching or exceeding marker	Probability of exactly reaching marker
B-C	0.03	0.00	0.00	0.03	0.03			N/A	N/A
B-A	0.25	0.03	0.30	0.87	1.21			N/A	N/A
C-AB	0.07	0.00	0.00	0.07	0.07			N/A	N/A

17:45 - 18:00

Stream	Mean (Veh)	Q05 (Veh)	Q50 (Veh)	Q90 (Veh)	Q95 (Veh)	Percentile message	Marker message	Probability of reaching or exceeding marker	Probability of exactly reaching marker
B-C	0.02	0.00	0.00	0.02	0.02			N/A	N/A
B-A	0.18	0.00	0.00	0.18	0.18			N/A	N/A
C-AB	0.05	0.00	0.00	0.05	0.05			N/A	N/A

18:00 - 18:15

Stream	Mean (Veh)	Q05 (Veh)	Q50 (Veh)	Q90 (Veh)	Q95 (Veh)	Percentile message	Marker message	Probability of reaching or exceeding marker	Probability of exactly reaching marker
B-C	0.02	0.00	0.00	0.02	0.02			N/A	N/A
B-A	0.13	0.00	0.00	0.13	0.13			N/A	N/A
C-AB	0.04	0.00	0.00	0.04	0.04			N/A	N/A

2027 Do Minimum, AM

Data Errors and Warnings

Severity	Area	Item	Description
Warning	Queue variations	Analysis Options	Queue percentiles may be unreliable if the mean queue in any time segment is very low or very high.

Junction Network

Junctions

Junction	Name	Junction type	Major road direction	Use circulating lanes	Junction Delay (s)	Junction LOS
1	Mill Lane/Delph Lane	T-Junction	Two-way		0.31	A

Junction Network Options

Driving side	Lighting
Left	Normal/unknown

Traffic Demand

Demand Set Details

ID	Scenario name	Time Period name	Traffic profile type	Start time (HH:mm)	Finish time (HH:mm)	Time segment length (min)
D7	2027 Do Minimum	AM	ONE HOUR	07:45	09:15	15

Vehicle mix source	PCU Factor for a HV (PCU)
HV Percentages	2.00

Demand overview (Traffic)

Arm	Linked arm	Use O-D data	Average Demand (Veh/hr)	Scaling Factor (%)
A		✓	410	100.000
B		✓	28	100.000
C		✓	565	100.000

Origin-Destination Data

Demand (Veh/hr)

		To		
		A	B	C
From	A	0	9	401
	B	17	0	11
	C	561	4	0

Vehicle Mix

Heavy Vehicle Percentages

		To		
		A	B	C
From	A	0	0	0
	B	6	0	0
	C	0	25	0

Results

Results Summary for whole modelled period

Stream	Max RFC	Max Delay (s)	Max Queue (Veh)	Max 95th percentile Queue (Veh)	Max LOS
B-C	0.02	5.62	0.0	0.5	A
B-A	0.06	11.37	0.1	0.5	B
C-AB	0.01	8.45	0.0	0.5	A
C-A					
A-B					
A-C					

Main Results for each time segment

07:45 - 08:00

Stream	Total Demand (Veh/hr)	Capacity (Veh/hr)	RFC	Throughput (Veh/hr)	End queue (Veh)	Delay (s)	Unsignalised level of service
B-C	8	697	0.012	8	0.0	5.223	A
B-A	13	396	0.032	13	0.0	9.376	A
C-AB	3	448	0.007	3	0.0	8.089	A
C-A	422			422			
A-B	7			7			
A-C	302			302			

08:00 - 08:15

Stream	Total Demand (Veh/hr)	Capacity (Veh/hr)	RFC	Throughput (Veh/hr)	End queue (Veh)	Delay (s)	Unsignalised level of service
B-C	10	679	0.015	10	0.0	5.380	A
B-A	15	371	0.041	15	0.0	10.123	B
C-AB	4	441	0.008	4	0.0	8.243	A
C-A	504			504			
A-B	8			8			
A-C	360			360			

08:15 - 08:30

Stream	Total Demand (Veh/hr)	Capacity (Veh/hr)	RFC	Throughput (Veh/hr)	End queue (Veh)	Delay (s)	Unsignalised level of service
B-C	12	653	0.019	12	0.0	5.616	A
B-A	19	335	0.056	19	0.1	11.363	B
C-AB	5	431	0.011	5	0.0	8.449	A
C-A	617			617			
A-B	10			10			
A-C	442			442			

08:30 - 08:45

Stream	Total Demand (Veh/hr)	Capacity (Veh/hr)	RFC	Throughput (Veh/hr)	End queue (Veh)	Delay (s)	Unsignalised level of service
B-C	12	653	0.019	12	0.0	5.616	A
B-A	19	335	0.056	19	0.1	11.369	B
C-AB	5	431	0.011	5	0.0	8.450	A
C-A	617			617			
A-B	10			10			
A-C	442			442			

08:45 - 09:00

Stream	Total Demand (Veh/hr)	Capacity (Veh/hr)	RFC	Throughput (Veh/hr)	End queue (Veh)	Delay (s)	Unsignalised level of service
B-C	10	679	0.015	10	0.0	5.381	A
B-A	15	371	0.041	15	0.0	10.130	B
C-AB	4	440	0.008	4	0.0	8.244	A
C-A	504			504			
A-B	8			8			
A-C	360			360			

09:00 - 09:15

Stream	Total Demand (Veh/hr)	Capacity (Veh/hr)	RFC	Throughput (Veh/hr)	End queue (Veh)	Delay (s)	Unsignalised level of service
B-C	8	697	0.012	8	0.0	5.226	A
B-A	13	396	0.032	13	0.0	9.386	A
C-AB	3	448	0.007	3	0.0	8.091	A
C-A	422			422			
A-B	7			7			
A-C	302			302			

Queue Variation Results for each time segment

07:45 - 08:00

Stream	Mean (Veh)	Q05 (Veh)	Q50 (Veh)	Q90 (Veh)	Q95 (Veh)	Percentile message	Marker message	Probability of reaching or exceeding marker	Probability of exactly reaching marker
B-C	0.01	0.00	0.00	0.01	0.01			N/A	N/A
B-A	0.03	0.00	0.00	0.03	0.03			N/A	N/A
C-AB	0.01	0.00	0.00	0.01	0.01			N/A	N/A

08:00 - 08:15

Stream	Mean (Veh)	Q05 (Veh)	Q50 (Veh)	Q90 (Veh)	Q95 (Veh)	Percentile message	Marker message	Probability of reaching or exceeding marker	Probability of exactly reaching marker
B-C	0.01	0.01	0.25	0.45	0.48			N/A	N/A
B-A	0.04	0.03	0.25	0.45	0.48			N/A	N/A
C-AB	0.01	0.01	0.25	0.45	0.48			N/A	N/A

08:15 - 08:30

Stream	Mean (Veh)	Q05 (Veh)	Q50 (Veh)	Q90 (Veh)	Q95 (Veh)	Percentile message	Marker message	Probability of reaching or exceeding marker	Probability of exactly reaching marker
B-C	0.02	0.00	0.00	0.02	0.02			N/A	N/A
B-A	0.06	0.03	0.26	0.46	0.49			N/A	N/A
C-AB	0.01	0.00	0.00	0.01	0.01			N/A	N/A

08:30 - 08:45

Stream	Mean (Veh)	Q05 (Veh)	Q50 (Veh)	Q90 (Veh)	Q95 (Veh)	Percentile message	Marker message	Probability of reaching or exceeding marker	Probability of exactly reaching marker
B-C	0.02	0.00	0.00	0.02	0.02			N/A	N/A
B-A	0.06	0.00	0.00	0.06	0.06			N/A	N/A
C-AB	0.01	0.00	0.00	0.01	0.01			N/A	N/A

08:45 - 09:00

Stream	Mean (Veh)	Q05 (Veh)	Q50 (Veh)	Q90 (Veh)	Q95 (Veh)	Percentile message	Marker message	Probability of reaching or exceeding marker	Probability of exactly reaching marker
B-C	0.01	0.00	0.00	0.01	0.01			N/A	N/A
B-A	0.04	0.00	0.00	0.04	0.04			N/A	N/A
C-AB	0.01	0.00	0.00	0.01	0.01			N/A	N/A

09:00 - 09:15

Stream	Mean (Veh)	Q05 (Veh)	Q50 (Veh)	Q90 (Veh)	Q95 (Veh)	Percentile message	Marker message	Probability of reaching or exceeding marker	Probability of exactly reaching marker
B-C	0.01	0.00	0.00	0.01	0.01			N/A	N/A
B-A	0.03	0.00	0.00	0.03	0.03			N/A	N/A
C-AB	0.01	0.00	0.00	0.01	0.01			N/A	N/A

2027 Do Minimum, PM

Data Errors and Warnings

Severity	Area	Item	Description
Warning	Queue variations	Analysis Options	Queue percentiles may be unreliable if the mean queue in any time segment is very low or very high.

Junction Network

Junctions

Junction	Name	Junction type	Major road direction	Use circulating lanes	Junction Delay (s)	Junction LOS
1	Mill Lane/Delph Lane	T-Junction	Two-way		0.47	A

Junction Network Options

Driving side	Lighting
Left	Normal/unknown

Traffic Demand

Demand Set Details

ID	Scenario name	Time Period name	Traffic profile type	Start time (HH:mm)	Finish time (HH:mm)	Time segment length (min)
D8	2027 Do Minimum	PM	ONE HOUR	16:45	18:15	15

Vehicle mix source	PCU Factor for a HV (PCU)
HV Percentages	2.00

Demand overview (Traffic)

Arm	Linked arm	Use O-D data	Average Demand (Veh/hr)	Scaling Factor (%)
A		✓	475	100.000
B		✓	31	100.000
C		✓	482	100.000

Origin-Destination Data

Demand (Veh/hr)

		To		
		A	B	C
From	A	0	38	437
	B	24	0	7
	C	464	18	0

Vehicle Mix

Heavy Vehicle Percentages

		To		
		A	B	C
From	A	0	0	0
	B	0	0	14
	C	1	6	0

Results

Results Summary for whole modelled period

Stream	Max RFC	Max Delay (s)	Max Queue (Veh)	Max 95th percentile Queue (Veh)	Max LOS
B-C	0.01	6.55	0.0	0.5	A
B-A	0.07	11.03	0.1	0.5	B
C-AB	0.04	7.53	0.0	0.5	A
C-A					
A-B					
A-C					

Main Results for each time segment

16:45 - 17:00

Stream	Total Demand (Veh/hr)	Capacity (Veh/hr)	RFC	Throughput (Veh/hr)	End queue (Veh)	Delay (s)	Unsignalised level of service
B-C	5	601	0.009	5	0.0	6.041	A
B-A	18	419	0.043	18	0.0	8.982	A
C-AB	14	520	0.027	14	0.0	7.107	A
C-A	349			349			
A-B	29			29			
A-C	329			329			

17:00 - 17:15

Stream	Total Demand (Veh/hr)	Capacity (Veh/hr)	RFC	Throughput (Veh/hr)	End queue (Veh)	Delay (s)	Unsignalised level of service
B-C	6	583	0.011	6	0.0	6.244	A
B-A	22	391	0.055	22	0.1	9.743	A
C-AB	17	511	0.033	17	0.0	7.290	A
C-A	417			417			
A-B	34			34			
A-C	393			393			

17:15 - 17:30

Stream	Total Demand (Veh/hr)	Capacity (Veh/hr)	RFC	Throughput (Veh/hr)	End queue (Veh)	Delay (s)	Unsignalised level of service
B-C	8	557	0.014	8	0.0	6.552	A
B-A	26	353	0.075	26	0.1	11.022	B
C-AB	21	499	0.042	21	0.0	7.530	A
C-A	510			510			
A-B	42			42			
A-C	481			481			

17:30 - 17:45

Stream	Total Demand (Veh/hr)	Capacity (Veh/hr)	RFC	Throughput (Veh/hr)	End queue (Veh)	Delay (s)	Unsignalised level of service
B-C	8	557	0.014	8	0.0	6.553	A
B-A	26	353	0.075	26	0.1	11.027	B
C-AB	21	499	0.042	21	0.0	7.533	A
C-A	510			510			
A-B	42			42			
A-C	481			481			

17:45 - 18:00

Stream	Total Demand (Veh/hr)	Capacity (Veh/hr)	RFC	Throughput (Veh/hr)	End queue (Veh)	Delay (s)	Unsignalised level of service
B-C	6	583	0.011	6	0.0	6.245	A
B-A	22	391	0.055	22	0.1	9.752	A
C-AB	17	510	0.033	17	0.0	7.295	A
C-A	417			417			
A-B	34			34			
A-C	393			393			

18:00 - 18:15

Stream	Total Demand (Veh/hr)	Capacity (Veh/hr)	RFC	Throughput (Veh/hr)	End queue (Veh)	Delay (s)	Unsignalised level of service
B-C	5	601	0.009	5	0.0	6.042	A
B-A	18	418	0.043	18	0.0	8.992	A
C-AB	14	520	0.027	14	0.0	7.111	A
C-A	349			349			
A-B	29			29			
A-C	329			329			

Queue Variation Results for each time segment

16:45 - 17:00

Stream	Mean (Veh)	Q05 (Veh)	Q50 (Veh)	Q90 (Veh)	Q95 (Veh)	Percentile message	Marker message	Probability of reaching or exceeding marker	Probability of exactly reaching marker
B-C	0.01	0.00	0.00	0.01	0.01			N/A	N/A
B-A	0.04	0.00	0.00	0.04	0.04			N/A	N/A
C-AB	0.03	0.00	0.00	0.03	0.03			N/A	N/A

17:00 - 17:15

Stream	Mean (Veh)	Q05 (Veh)	Q50 (Veh)	Q90 (Veh)	Q95 (Veh)	Percentile message	Marker message	Probability of reaching or exceeding marker	Probability of exactly reaching marker
B-C	0.01	0.01	0.25	0.45	0.48			N/A	N/A
B-A	0.06	0.03	0.25	0.45	0.48			N/A	N/A
C-AB	0.03	0.03	0.25	0.45	0.48			N/A	N/A

17:15 - 17:30

Stream	Mean (Veh)	Q05 (Veh)	Q50 (Veh)	Q90 (Veh)	Q95 (Veh)	Percentile message	Marker message	Probability of reaching or exceeding marker	Probability of exactly reaching marker
B-C	0.01	0.00	0.00	0.01	0.01			N/A	N/A
B-A	0.08	0.03	0.26	0.47	0.49			N/A	N/A
C-AB	0.05	0.03	0.25	0.46	0.48			N/A	N/A

17:30 - 17:45

Stream	Mean (Veh)	Q05 (Veh)	Q50 (Veh)	Q90 (Veh)	Q95 (Veh)	Percentile message	Marker message	Probability of reaching or exceeding marker	Probability of exactly reaching marker
B-C	0.01	0.00	0.00	0.01	0.01			N/A	N/A
B-A	0.08	0.03	0.25	0.45	0.48			N/A	N/A
C-AB	0.05	0.00	0.00	0.05	0.05			N/A	N/A

17:45 - 18:00

Stream	Mean (Veh)	Q05 (Veh)	Q50 (Veh)	Q90 (Veh)	Q95 (Veh)	Percentile message	Marker message	Probability of reaching or exceeding marker	Probability of exactly reaching marker
B-C	0.01	0.00	0.00	0.01	0.01			N/A	N/A
B-A	0.06	0.00	0.00	0.06	0.06			N/A	N/A
C-AB	0.04	0.00	0.00	0.04	0.04			N/A	N/A

18:00 - 18:15

Stream	Mean (Veh)	Q05 (Veh)	Q50 (Veh)	Q90 (Veh)	Q95 (Veh)	Percentile message	Marker message	Probability of reaching or exceeding marker	Probability of exactly reaching marker
B-C	0.01	0.00	0.00	0.01	0.01			N/A	N/A
B-A	0.05	0.00	0.00	0.05	0.05			N/A	N/A
C-AB	0.03	0.00	0.00	0.03	0.03			N/A	N/A

2027 Do Something, AM

Data Errors and Warnings

Severity	Area	Item	Description
Warning	Queue variations	Analysis Options	Queue percentiles may be unreliable if the mean queue in any time segment is very low or very high.

Junction Network

Junctions

Junction	Name	Junction type	Major road direction	Use circulating lanes	Junction Delay (s)	Junction LOS
1	Mill Lane/Delph Lane	T-Junction	Two-way		1.27	A

Junction Network Options

Driving side	Lighting
Left	Normal/unknown

Traffic Demand

Demand Set Details

ID	Scenario name	Time Period name	Traffic profile type	Start time (HH:mm)	Finish time (HH:mm)	Time segment length (min)
D9	2027 Do Something	AM	ONE HOUR	07:45	09:15	15

Vehicle mix source	PCU Factor for a HV (PCU)
HV Percentages	2.00

Demand overview (Traffic)

Arm	Linked arm	Use O-D data	Average Demand (Veh/hr)	Scaling Factor (%)
A		✓	461	100.000
B		✓	107	100.000
C		✓	578	100.000

Origin-Destination Data

Demand (Veh/hr)

		To		
		A	B	C
From	A	0	38	423
	B	84	0	23
	C	569	9	0

Vehicle Mix

Heavy Vehicle Percentages

		To		
		A	B	C
From	A	0	0	0
	B	1	0	0
	C	0	11	0

Results

Results Summary for whole modelled period

Stream	Max RFC	Max Delay (s)	Max Queue (Veh)	Max 95th percentile Queue (Veh)	Max LOS
B-C	0.04	6.19	0.0	0.5	A
B-A	0.27	14.55	0.4	1.4	B
C-AB	0.02	7.75	0.0	0.5	A
C-A					
A-B					
A-C					

Main Results for each time segment

07:45 - 08:00

Stream	Total Demand (Veh/hr)	Capacity (Veh/hr)	RFC	Throughput (Veh/hr)	End queue (Veh)	Delay (s)	Unsignalised level of service
B-C	17	669	0.026	17	0.0	5.524	A
B-A	63	408	0.155	63	0.2	10.403	B
C-AB	7	497	0.014	7	0.0	7.344	A
C-A	428			428			
A-B	29			29			
A-C	318			318			

08:00 - 08:15

Stream	Total Demand (Veh/hr)	Capacity (Veh/hr)	RFC	Throughput (Veh/hr)	End queue (Veh)	Delay (s)	Unsignalised level of service
B-C	21	643	0.032	21	0.0	5.781	A
B-A	76	379	0.199	75	0.2	11.832	B
C-AB	8	487	0.017	8	0.0	7.515	A
C-A	511			511			
A-B	34			34			
A-C	380			380			

08:15 - 08:30

Stream	Total Demand (Veh/hr)	Capacity (Veh/hr)	RFC	Throughput (Veh/hr)	End queue (Veh)	Delay (s)	Unsignalised level of service
B-C	25	607	0.042	25	0.0	6.189	A
B-A	92	340	0.272	92	0.4	14.497	B
C-AB	10	475	0.022	10	0.0	7.746	A
C-A	626			626			
A-B	42			42			
A-C	466			466			

08:30 - 08:45

Stream	Total Demand (Veh/hr)	Capacity (Veh/hr)	RFC	Throughput (Veh/hr)	End queue (Veh)	Delay (s)	Unsignalised level of service
B-C	25	607	0.042	25	0.0	6.191	A
B-A	92	340	0.272	92	0.4	14.551	B
C-AB	10	475	0.022	10	0.0	7.746	A
C-A	626			626			
A-B	42			42			
A-C	466			466			

08:45 - 09:00

Stream	Total Demand (Veh/hr)	Capacity (Veh/hr)	RFC	Throughput (Veh/hr)	End queue (Veh)	Delay (s)	Unsignalised level of service
B-C	21	643	0.032	21	0.0	5.785	A
B-A	76	379	0.199	76	0.3	11.890	B
C-AB	8	487	0.017	8	0.0	7.516	A
C-A	511			511			
A-B	34			34			
A-C	380			380			

09:00 - 09:15

Stream	Total Demand (Veh/hr)	Capacity (Veh/hr)	RFC	Throughput (Veh/hr)	End queue (Veh)	Delay (s)	Unsignalised level of service
B-C	17	668	0.026	17	0.0	5.531	A
B-A	63	408	0.155	64	0.2	10.465	B
C-AB	7	497	0.014	7	0.0	7.347	A
C-A	428			428			
A-B	29			29			
A-C	318			318			

Queue Variation Results for each time segment**07:45 - 08:00**

Stream	Mean (Veh)	Q05 (Veh)	Q50 (Veh)	Q90 (Veh)	Q95 (Veh)	Percentile message	Marker message	Probability of reaching or exceeding marker	Probability of exactly reaching marker
B-C	0.03	0.00	0.00	0.03	0.03			N/A	N/A
B-A	0.18	0.00	0.00	0.18	0.18			N/A	N/A
C-AB	0.01	0.00	0.00	0.01	0.01			N/A	N/A

08:00 - 08:15

Stream	Mean (Veh)	Q05 (Veh)	Q50 (Veh)	Q90 (Veh)	Q95 (Veh)	Percentile message	Marker message	Probability of reaching or exceeding marker	Probability of exactly reaching marker
B-C	0.03	0.03	0.25	0.45	0.48			N/A	N/A
B-A	0.24	0.00	0.00	0.24	0.24			N/A	N/A
C-AB	0.02	0.02	0.25	0.45	0.48			N/A	N/A

08:15 - 08:30

Stream	Mean (Veh)	Q05 (Veh)	Q50 (Veh)	Q90 (Veh)	Q95 (Veh)	Percentile message	Marker message	Probability of reaching or exceeding marker	Probability of exactly reaching marker
B-C	0.04	0.03	0.25	0.46	0.48			N/A	N/A
B-A	0.37	0.03	0.26	0.46	0.49			N/A	N/A
C-AB	0.02	0.00	0.00	0.02	0.02			N/A	N/A

08:30 - 08:45

Stream	Mean (Veh)	Q05 (Veh)	Q50 (Veh)	Q90 (Veh)	Q95 (Veh)	Percentile message	Marker message	Probability of reaching or exceeding marker	Probability of exactly reaching marker
B-C	0.04	0.00	0.00	0.04	0.04			N/A	N/A
B-A	0.37	0.03	0.31	1.24	1.35			N/A	N/A
C-AB	0.02	0.00	0.00	0.02	0.02			N/A	N/A

08:45 - 09:00

Stream	Mean (Veh)	Q05 (Veh)	Q50 (Veh)	Q90 (Veh)	Q95 (Veh)	Percentile message	Marker message	Probability of reaching or exceeding marker	Probability of exactly reaching marker
B-C	0.03	0.00	0.00	0.03	0.03			N/A	N/A
B-A	0.25	0.00	0.00	0.25	0.25			N/A	N/A
C-AB	0.02	0.00	0.00	0.02	0.02			N/A	N/A

09:00 - 09:15

Stream	Mean (Veh)	Q05 (Veh)	Q50 (Veh)	Q90 (Veh)	Q95 (Veh)	Percentile message	Marker message	Probability of reaching or exceeding marker	Probability of exactly reaching marker
B-C	0.03	0.00	0.00	0.03	0.03			N/A	N/A
B-A	0.19	0.00	0.00	0.19	0.19			N/A	N/A
C-AB	0.01	0.00	0.00	0.01	0.01			N/A	N/A

2027 Do Something, PM

Data Errors and Warnings

Severity	Area	Item	Description
Warning	Queue variations	Analysis Options	Queue percentiles may be unreliable if the mean queue in any time segment is very low or very high.

Junction Network

Junctions

Junction	Name	Junction type	Major road direction	Use circulating lanes	Junction Delay (s)	Junction LOS
1	Mill Lane/Delph Lane	T-Junction	Two-way		1.02	A

Junction Network Options

Driving side	Lighting
Left	Normal/unknown

Traffic Demand

Demand Set Details

ID	Scenario name	Time Period name	Traffic profile type	Start time (HH:mm)	Finish time (HH:mm)	Time segment length (min)
D10	2027 Do Something	PM	ONE HOUR	16:45	18:15	15

Vehicle mix source	PCU Factor for a HV (PCU)
HV Percentages	2.00

Demand overview (Traffic)

Arm	Linked arm	Use O-D data	Average Demand (Veh/hr)	Scaling Factor (%)
A		✓	572	100.000
B		✓	77	100.000
C		✓	512	100.000

Origin-Destination Data

Demand (Veh/hr)

		To		
		A	B	C
From	A	0	105	467
	B	64	0	13
	C	487	25	0

Vehicle Mix

Heavy Vehicle Percentages

		To		
		A	B	C
From	A	0	0	0
	B	0	0	8
	C	0	4	0

Results

Results Summary for whole modelled period

Stream	Max RFC	Max Delay (s)	Max Queue (Veh)	Max 95th percentile Queue (Veh)	Max LOS
B-C	0.03	6.70	0.0	0.5	A
B-A	0.21	13.77	0.3	1.3	B
C-AB	0.06	7.74	0.1	0.5	A
C-A					
A-B					
A-C					

Main Results for each time segment

16:45 - 17:00

Stream	Total Demand (Veh/hr)	Capacity (Veh/hr)	RFC	Throughput (Veh/hr)	End queue (Veh)	Delay (s)	Unsignalised level of service
B-C	10	611	0.016	10	0.0	5.984	A
B-A	48	404	0.119	48	0.1	10.080	B
C-AB	19	518	0.037	19	0.0	7.214	A
C-A	366			366			
A-B	79			79			
A-C	352			352			

17:00 - 17:15

Stream	Total Demand (Veh/hr)	Capacity (Veh/hr)	RFC	Throughput (Veh/hr)	End queue (Veh)	Delay (s)	Unsignalised level of service
B-C	12	586	0.020	12	0.0	6.262	A
B-A	58	374	0.154	57	0.2	11.364	B
C-AB	24	507	0.046	23	0.1	7.442	A
C-A	437			437			
A-B	94			94			
A-C	420			420			

17:15 - 17:30

Stream	Total Demand (Veh/hr)	Capacity (Veh/hr)	RFC	Throughput (Veh/hr)	End queue (Veh)	Delay (s)	Unsignalised level of service
B-C	14	551	0.026	14	0.0	6.701	A
B-A	70	332	0.212	70	0.3	13.730	B
C-AB	30	495	0.060	30	0.1	7.735	A
C-A	534			534			
A-B	116			116			
A-C	514			514			

17:30 - 17:45

Stream	Total Demand (Veh/hr)	Capacity (Veh/hr)	RFC	Throughput (Veh/hr)	End queue (Veh)	Delay (s)	Unsignalised level of service
B-C	14	551	0.026	14	0.0	6.703	A
B-A	70	332	0.212	70	0.3	13.766	B
C-AB	30	495	0.060	30	0.1	7.739	A
C-A	534			534			
A-B	116			116			
A-C	514			514			

17:45 - 18:00

Stream	Total Demand (Veh/hr)	Capacity (Veh/hr)	RFC	Throughput (Veh/hr)	End queue (Veh)	Delay (s)	Unsignalised level of service
B-C	12	586	0.020	12	0.0	6.265	A
B-A	58	374	0.154	58	0.2	11.404	B
C-AB	24	507	0.046	24	0.1	7.447	A
C-A	437			437			
A-B	94			94			
A-C	420			420			

18:00 - 18:15

Stream	Total Demand (Veh/hr)	Capacity (Veh/hr)	RFC	Throughput (Veh/hr)	End queue (Veh)	Delay (s)	Unsignalised level of service
B-C	10	611	0.016	10	0.0	5.987	A
B-A	48	404	0.119	48	0.1	10.124	B
C-AB	19	518	0.037	19	0.0	7.218	A
C-A	366			366			
A-B	79			79			
A-C	352			352			

Queue Variation Results for each time segment

16:45 - 17:00

Stream	Mean (Veh)	Q05 (Veh)	Q50 (Veh)	Q90 (Veh)	Q95 (Veh)	Percentile message	Marker message	Probability of reaching or exceeding marker	Probability of exactly reaching marker
B-C	0.02	0.00	0.00	0.02	0.02			N/A	N/A
B-A	0.13	0.00	0.00	0.13	0.13			N/A	N/A
C-AB	0.04	0.00	0.00	0.04	0.04			N/A	N/A

17:00 - 17:15

Stream	Mean (Veh)	Q05 (Veh)	Q50 (Veh)	Q90 (Veh)	Q95 (Veh)	Percentile message	Marker message	Probability of reaching or exceeding marker	Probability of exactly reaching marker
B-C	0.02	0.02	0.25	0.45	0.48			N/A	N/A
B-A	0.18	0.00	0.00	0.18	0.18			N/A	N/A
C-AB	0.05	0.03	0.25	0.45	0.48			N/A	N/A

17:15 - 17:30

Stream	Mean (Veh)	Q05 (Veh)	Q50 (Veh)	Q90 (Veh)	Q95 (Veh)	Percentile message	Marker message	Probability of reaching or exceeding marker	Probability of exactly reaching marker
B-C	0.03	0.00	0.00	0.03	0.03			N/A	N/A
B-A	0.26	0.03	0.26	0.46	0.49			N/A	N/A
C-AB	0.07	0.03	0.26	0.47	0.49			N/A	N/A

17:30 - 17:45

Stream	Mean (Veh)	Q05 (Veh)	Q50 (Veh)	Q90 (Veh)	Q95 (Veh)	Percentile message	Marker message	Probability of reaching or exceeding marker	Probability of exactly reaching marker
B-C	0.03	0.00	0.00	0.03	0.03			N/A	N/A
B-A	0.27	0.03	0.30	0.94	1.26			N/A	N/A
C-AB	0.07	0.00	0.00	0.07	0.07			N/A	N/A

17:45 - 18:00

Stream	Mean (Veh)	Q05 (Veh)	Q50 (Veh)	Q90 (Veh)	Q95 (Veh)	Percentile message	Marker message	Probability of reaching or exceeding marker	Probability of exactly reaching marker
B-C	0.02	0.00	0.00	0.02	0.02			N/A	N/A
B-A	0.18	0.00	0.00	0.18	0.18			N/A	N/A
C-AB	0.05	0.00	0.00	0.05	0.05			N/A	N/A

18:00 - 18:15

Stream	Mean (Veh)	Q05 (Veh)	Q50 (Veh)	Q90 (Veh)	Q95 (Veh)	Percentile message	Marker message	Probability of reaching or exceeding marker	Probability of exactly reaching marker
B-C	0.02	0.00	0.00	0.02	0.02			N/A	N/A
B-A	0.14	0.00	0.00	0.14	0.14			N/A	N/A
C-AB	0.04	0.00	0.00	0.04	0.04			N/A	N/A

2032 Do Minimum, AM

Data Errors and Warnings

Severity	Area	Item	Description
Warning	Queue variations	Analysis Options	Queue percentiles may be unreliable if the mean queue in any time segment is very low or very high.

Junction Network

Junctions

Junction	Name	Junction type	Major road direction	Use circulating lanes	Junction Delay (s)	Junction LOS
1	Mill Lane/Delph Lane	T-Junction	Two-way		0.30	A

Junction Network Options

Driving side	Lighting
Left	Normal/unknown

Traffic Demand

Demand Set Details

ID	Scenario name	Time Period name	Traffic profile type	Start time (HH:mm)	Finish time (HH:mm)	Time segment length (min)
D11	2032 Do Minimum	AM	ONE HOUR	07:45	09:15	15

Vehicle mix source	PCU Factor for a HV (PCU)
HV Percentages	2.00

Demand overview (Traffic)

Arm	Linked arm	Use O-D data	Average Demand (Veh/hr)	Scaling Factor (%)
A		✓	424	100.000
B		✓	28	100.000
C		✓	611	100.000

Origin-Destination Data

Demand (Veh/hr)

		To		
		A	B	C
From	A	0	9	415
	B	17	0	11
	C	607	4	0

Vehicle Mix

Heavy Vehicle Percentages

		To		
		A	B	C
From	A	0	0	0
	B	6	0	0
	C	0	25	0

Results

Results Summary for whole modelled period

Stream	Max RFC	Max Delay (s)	Max Queue (Veh)	Max 95th percentile Queue (Veh)	Max LOS
B-C	0.02	5.66	0.0	0.5	A
B-A	0.06	11.77	0.1	0.5	B
C-AB	0.01	8.48	0.0	0.5	A
C-A					
A-B					
A-C					

Main Results for each time segment

07:45 - 08:00

Stream	Total Demand (Veh/hr)	Capacity (Veh/hr)	RFC	Throughput (Veh/hr)	End queue (Veh)	Delay (s)	Unsignalised level of service
B-C	8	694	0.012	8	0.0	5.247	A
B-A	13	389	0.033	13	0.0	9.561	A
C-AB	3	447	0.007	3	0.0	8.112	A
C-A	457			457			
A-B	7			7			
A-C	312			312			

08:00 - 08:15

Stream	Total Demand (Veh/hr)	Capacity (Veh/hr)	RFC	Throughput (Veh/hr)	End queue (Veh)	Delay (s)	Unsignalised level of service
B-C	10	675	0.015	10	0.0	5.411	A
B-A	15	362	0.042	15	0.0	10.381	B
C-AB	4	439	0.008	4	0.0	8.269	A
C-A	546			546			
A-B	8			8			
A-C	373			373			

08:15 - 08:30

Stream	Total Demand (Veh/hr)	Capacity (Veh/hr)	RFC	Throughput (Veh/hr)	End queue (Veh)	Delay (s)	Unsignalised level of service
B-C	12	648	0.019	12	0.0	5.657	A
B-A	19	324	0.058	19	0.1	11.768	B
C-AB	5	430	0.011	5	0.0	8.476	A
C-A	668			668			
A-B	10			10			
A-C	457			457			

08:30 - 08:45

Stream	Total Demand (Veh/hr)	Capacity (Veh/hr)	RFC	Throughput (Veh/hr)	End queue (Veh)	Delay (s)	Unsignalised level of service
B-C	12	648	0.019	12	0.0	5.658	A
B-A	19	324	0.058	19	0.1	11.773	B
C-AB	5	429	0.011	5	0.0	8.478	A
C-A	668			668			
A-B	10			10			
A-C	457			457			

08:45 - 09:00

Stream	Total Demand (Veh/hr)	Capacity (Veh/hr)	RFC	Throughput (Veh/hr)	End queue (Veh)	Delay (s)	Unsignalised level of service
B-C	10	675	0.015	10	0.0	5.414	A
B-A	15	362	0.042	15	0.0	10.390	B
C-AB	4	438	0.008	4	0.0	8.269	A
C-A	546			546			
A-B	8			8			
A-C	373			373			

09:00 - 09:15

Stream	Total Demand (Veh/hr)	Capacity (Veh/hr)	RFC	Throughput (Veh/hr)	End queue (Veh)	Delay (s)	Unsignalised level of service
B-C	8	694	0.012	8	0.0	5.250	A
B-A	13	389	0.033	13	0.0	9.569	A
C-AB	3	446	0.007	3	0.0	8.112	A
C-A	457			457			
A-B	7			7			
A-C	312			312			

Queue Variation Results for each time segment

07:45 - 08:00

Stream	Mean (Veh)	Q05 (Veh)	Q50 (Veh)	Q90 (Veh)	Q95 (Veh)	Percentile message	Marker message	Probability of reaching or exceeding marker	Probability of exactly reaching marker
B-C	0.01	0.00	0.00	0.01	0.01			N/A	N/A
B-A	0.03	0.00	0.00	0.03	0.03			N/A	N/A
C-AB	0.01	0.00	0.00	0.01	0.01			N/A	N/A

08:00 - 08:15

Stream	Mean (Veh)	Q05 (Veh)	Q50 (Veh)	Q90 (Veh)	Q95 (Veh)	Percentile message	Marker message	Probability of reaching or exceeding marker	Probability of exactly reaching marker
B-C	0.01	0.01	0.25	0.45	0.48			N/A	N/A
B-A	0.04	0.03	0.25	0.45	0.48			N/A	N/A
C-AB	0.01	0.01	0.25	0.45	0.48			N/A	N/A

08:15 - 08:30

Stream	Mean (Veh)	Q05 (Veh)	Q50 (Veh)	Q90 (Veh)	Q95 (Veh)	Percentile message	Marker message	Probability of reaching or exceeding marker	Probability of exactly reaching marker
B-C	0.02	0.00	0.00	0.02	0.02			N/A	N/A
B-A	0.06	0.03	0.26	0.46	0.49			N/A	N/A
C-AB	0.01	0.00	0.00	0.01	0.01			N/A	N/A

08:30 - 08:45

Stream	Mean (Veh)	Q05 (Veh)	Q50 (Veh)	Q90 (Veh)	Q95 (Veh)	Percentile message	Marker message	Probability of reaching or exceeding marker	Probability of exactly reaching marker
B-C	0.02	0.00	0.00	0.02	0.02			N/A	N/A
B-A	0.06	0.00	0.00	0.06	0.06			N/A	N/A
C-AB	0.01	0.00	0.00	0.01	0.01			N/A	N/A

08:45 - 09:00

Stream	Mean (Veh)	Q05 (Veh)	Q50 (Veh)	Q90 (Veh)	Q95 (Veh)	Percentile message	Marker message	Probability of reaching or exceeding marker	Probability of exactly reaching marker
B-C	0.01	0.00	0.00	0.01	0.01			N/A	N/A
B-A	0.04	0.00	0.00	0.04	0.04			N/A	N/A
C-AB	0.01	0.00	0.00	0.01	0.01			N/A	N/A

09:00 - 09:15

Stream	Mean (Veh)	Q05 (Veh)	Q50 (Veh)	Q90 (Veh)	Q95 (Veh)	Percentile message	Marker message	Probability of reaching or exceeding marker	Probability of exactly reaching marker
B-C	0.01	0.00	0.00	0.01	0.01			N/A	N/A
B-A	0.03	0.00	0.00	0.03	0.03			N/A	N/A
C-AB	0.01	0.00	0.00	0.01	0.01			N/A	N/A

2032 Do Minimum, PM

Data Errors and Warnings

Severity	Area	Item	Description
Warning	Queue variations	Analysis Options	Queue percentiles may be unreliable if the mean queue in any time segment is very low or very high.

Junction Network

Junctions

Junction	Name	Junction type	Major road direction	Use circulating lanes	Junction Delay (s)	Junction LOS
1	Mill Lane/Delph Lane	T-Junction	Two-way		0.46	A

Junction Network Options

Driving side	Lighting
Left	Normal/unknown

Traffic Demand

Demand Set Details

ID	Scenario name	Time Period name	Traffic profile type	Start time (HH:mm)	Finish time (HH:mm)	Time segment length (min)
D12	2032 Do Minimum	PM	ONE HOUR	16:45	18:15	15

Vehicle mix source	PCU Factor for a HV (PCU)
HV Percentages	2.00

Demand overview (Traffic)

Arm	Linked arm	Use O-D data	Average Demand (Veh/hr)	Scaling Factor (%)
A		✓	509	100.000
B		✓	31	100.000
C		✓	510	100.000

Origin-Destination Data

Demand (Veh/hr)

		To		
		A	B	C
From	A	0	38	471
	B	24	0	7
	C	492	18	0

Vehicle Mix

Heavy Vehicle Percentages

		To		
		A	B	C
From	A	0	0	0
	B	0	0	14
	C	0	6	0

Results

Results Summary for whole modelled period

Stream	Max RFC	Max Delay (s)	Max Queue (Veh)	Max 95th percentile Queue (Veh)	Max LOS
B-C	0.01	6.67	0.0	0.5	A
B-A	0.08	11.49	0.1	0.5	B
C-AB	0.04	7.63	0.0	0.5	A
C-A					
A-B					
A-C					

Main Results for each time segment

16:45 - 17:00

Stream	Total Demand (Veh/hr)	Capacity (Veh/hr)	RFC	Throughput (Veh/hr)	End queue (Veh)	Delay (s)	Unsignalised level of service
B-C	5	595	0.009	5	0.0	6.108	A
B-A	18	410	0.044	18	0.0	9.186	A
C-AB	14	515	0.027	14	0.0	7.173	A
C-A	370			370			
A-B	29			29			
A-C	355			355			

17:00 - 17:15

Stream	Total Demand (Veh/hr)	Capacity (Veh/hr)	RFC	Throughput (Veh/hr)	End queue (Veh)	Delay (s)	Unsignalised level of service
B-C	6	575	0.011	6	0.0	6.331	A
B-A	22	380	0.057	22	0.1	10.032	B
C-AB	17	505	0.033	17	0.0	7.371	A
C-A	442			442			
A-B	34			34			
A-C	423			423			

17:15 - 17:30

Stream	Total Demand (Veh/hr)	Capacity (Veh/hr)	RFC	Throughput (Veh/hr)	End queue (Veh)	Delay (s)	Unsignalised level of service
B-C	8	547	0.014	8	0.0	6.670	A
B-A	26	340	0.078	26	0.1	11.479	B
C-AB	21	493	0.043	21	0.0	7.627	A
C-A	541			541			
A-B	42			42			
A-C	519			519			

17:30 - 17:45

Stream	Total Demand (Veh/hr)	Capacity (Veh/hr)	RFC	Throughput (Veh/hr)	End queue (Veh)	Delay (s)	Unsignalised level of service
B-C	8	547	0.014	8	0.0	6.671	A
B-A	26	340	0.078	26	0.1	11.486	B
C-AB	21	493	0.043	21	0.0	7.631	A
C-A	541			541			
A-B	42			42			
A-C	519			519			

17:45 - 18:00

Stream	Total Demand (Veh/hr)	Capacity (Veh/hr)	RFC	Throughput (Veh/hr)	End queue (Veh)	Delay (s)	Unsignalised level of service
B-C	6	575	0.011	6	0.0	6.332	A
B-A	22	380	0.057	22	0.1	10.040	B
C-AB	17	505	0.033	17	0.0	7.372	A
C-A	442			442			
A-B	34			34			
A-C	423			423			

18:00 - 18:15

Stream	Total Demand (Veh/hr)	Capacity (Veh/hr)	RFC	Throughput (Veh/hr)	End queue (Veh)	Delay (s)	Unsignalised level of service
B-C	5	594	0.009	5	0.0	6.111	A
B-A	18	410	0.044	18	0.0	9.197	A
C-AB	14	515	0.027	14	0.0	7.180	A
C-A	370			370			
A-B	29			29			
A-C	355			355			

Queue Variation Results for each time segment

16:45 - 17:00

Stream	Mean (Veh)	Q05 (Veh)	Q50 (Veh)	Q90 (Veh)	Q95 (Veh)	Percentile message	Marker message	Probability of reaching or exceeding marker	Probability of exactly reaching marker
B-C	0.01	0.00	0.00	0.01	0.01			N/A	N/A
B-A	0.05	0.00	0.00	0.05	0.05			N/A	N/A
C-AB	0.03	0.00	0.00	0.03	0.03			N/A	N/A

17:00 - 17:15

Stream	Mean (Veh)	Q05 (Veh)	Q50 (Veh)	Q90 (Veh)	Q95 (Veh)	Percentile message	Marker message	Probability of reaching or exceeding marker	Probability of exactly reaching marker
B-C	0.01	0.01	0.25	0.45	0.48			N/A	N/A
B-A	0.06	0.03	0.25	0.45	0.48			N/A	N/A
C-AB	0.04	0.03	0.25	0.45	0.48			N/A	N/A

17:15 - 17:30

Stream	Mean (Veh)	Q05 (Veh)	Q50 (Veh)	Q90 (Veh)	Q95 (Veh)	Percentile message	Marker message	Probability of reaching or exceeding marker	Probability of exactly reaching marker
B-C	0.01	0.00	0.00	0.01	0.01			N/A	N/A
B-A	0.08	0.03	0.26	0.47	0.49			N/A	N/A
C-AB	0.05	0.03	0.25	0.46	0.48			N/A	N/A

17:30 - 17:45

Stream	Mean (Veh)	Q05 (Veh)	Q50 (Veh)	Q90 (Veh)	Q95 (Veh)	Percentile message	Marker message	Probability of reaching or exceeding marker	Probability of exactly reaching marker
B-C	0.01	0.00	0.00	0.01	0.01			N/A	N/A
B-A	0.08	0.03	0.25	0.45	0.48			N/A	N/A
C-AB	0.05	0.00	0.00	0.05	0.05			N/A	N/A

17:45 - 18:00

Stream	Mean (Veh)	Q05 (Veh)	Q50 (Veh)	Q90 (Veh)	Q95 (Veh)	Percentile message	Marker message	Probability of reaching or exceeding marker	Probability of exactly reaching marker
B-C	0.01	0.00	0.00	0.01	0.01			N/A	N/A
B-A	0.06	0.00	0.00	0.06	0.06			N/A	N/A
C-AB	0.04	0.00	0.00	0.04	0.04			N/A	N/A

18:00 - 18:15

Stream	Mean (Veh)	Q05 (Veh)	Q50 (Veh)	Q90 (Veh)	Q95 (Veh)	Percentile message	Marker message	Probability of reaching or exceeding marker	Probability of exactly reaching marker
B-C	0.01	0.00	0.00	0.01	0.01			N/A	N/A
B-A	0.05	0.00	0.00	0.05	0.05			N/A	N/A
C-AB	0.03	0.00	0.00	0.03	0.03			N/A	N/A

2032 Do Something (FULL), AM

Data Errors and Warnings

Severity	Area	Item	Description
Warning	Queue variations	Analysis Options	Queue percentiles may be unreliable if the mean queue in any time segment is very low or very high.

Junction Network

Junctions

Junction	Name	Junction type	Major road direction	Use circulating lanes	Junction Delay (s)	Junction LOS
1	Mill Lane/Delph Lane	T-Junction	Two-way		1.30	A

Junction Network Options

Driving side	Lighting
Left	Normal/unknown

Traffic Demand

Demand Set Details

ID	Scenario name	Time Period name	Traffic profile type	Start time (HH:mm)	Finish time (HH:mm)	Time segment length (min)
D13	2032 Do Something (FULL)	AM	ONE HOUR	07:45	09:15	15

Vehicle mix source	PCU Factor for a HV (PCU)
HV Percentages	2.00

Demand overview (Traffic)

Arm	Linked arm	Use O-D data	Average Demand (Veh/hr)	Scaling Factor (%)
A		✓	492	100.000
B		✓	107	100.000
C		✓	632	100.000

Origin-Destination Data

Demand (Veh/hr)

		To		
		A	B	C
From	A	0	38	454
	B	87	0	20
	C	623	9	0

Vehicle Mix

Heavy Vehicle Percentages

		To		
		A	B	C
From	A	0	0	0
	B	1	0	0
	C	0	11	0

Results

Results Summary for whole modelled period

Stream	Max RFC	Max Delay (s)	Max Queue (Veh)	Max 95th percentile Queue (Veh)	Max LOS
B-C	0.04	6.30	0.0	0.5	A
B-A	0.30	15.87	0.4	1.7	C
C-AB	0.02	7.83	0.0	0.5	A
C-A					
A-B					
A-C					

Main Results for each time segment

07:45 - 08:00

Stream	Total Demand (Veh/hr)	Capacity (Veh/hr)	RFC	Throughput (Veh/hr)	End queue (Veh)	Delay (s)	Unsignalised level of service
B-C	15	661	0.023	15	0.0	5.576	A
B-A	65	396	0.165	65	0.2	10.841	B
C-AB	7	493	0.014	7	0.0	7.402	A
C-A	469			469			
A-B	29			29			
A-C	342			342			

08:00 - 08:15

Stream	Total Demand (Veh/hr)	Capacity (Veh/hr)	RFC	Throughput (Veh/hr)	End queue (Veh)	Delay (s)	Unsignalised level of service
B-C	18	633	0.028	18	0.0	5.852	A
B-A	78	365	0.214	78	0.3	12.518	B
C-AB	8	483	0.017	8	0.0	7.584	A
C-A	560			560			
A-B	34			34			
A-C	408			408			

08:15 - 08:30

Stream	Total Demand (Veh/hr)	Capacity (Veh/hr)	RFC	Throughput (Veh/hr)	End queue (Veh)	Delay (s)	Unsignalised level of service
B-C	22	594	0.037	22	0.0	6.297	A
B-A	96	323	0.297	95	0.4	15.792	C
C-AB	10	471	0.022	10	0.0	7.827	A
C-A	685			685			
A-B	42			42			
A-C	500			500			

08:30 - 08:45

Stream	Total Demand (Veh/hr)	Capacity (Veh/hr)	RFC	Throughput (Veh/hr)	End queue (Veh)	Delay (s)	Unsignalised level of service
B-C	22	593	0.037	22	0.0	6.300	A
B-A	96	323	0.297	96	0.4	15.869	C
C-AB	10	470	0.022	10	0.0	7.829	A
C-A	685			685			
A-B	42			42			
A-C	500			500			

08:45 - 09:00

Stream	Total Demand (Veh/hr)	Capacity (Veh/hr)	RFC	Throughput (Veh/hr)	End queue (Veh)	Delay (s)	Unsignalised level of service
B-C	18	633	0.028	18	0.0	5.856	A
B-A	78	365	0.214	79	0.3	12.595	B
C-AB	8	482	0.017	8	0.0	7.588	A
C-A	560			560			
A-B	34			34			
A-C	408			408			

09:00 - 09:15

Stream	Total Demand (Veh/hr)	Capacity (Veh/hr)	RFC	Throughput (Veh/hr)	End queue (Veh)	Delay (s)	Unsignalised level of service
B-C	15	660	0.023	15	0.0	5.583	A
B-A	65	396	0.165	66	0.2	10.913	B
C-AB	7	493	0.014	7	0.0	7.405	A
C-A	469			469			
A-B	29			29			
A-C	342			342			

Queue Variation Results for each time segment

07:45 - 08:00

Stream	Mean (Veh)	Q05 (Veh)	Q50 (Veh)	Q90 (Veh)	Q95 (Veh)	Percentile message	Marker message	Probability of reaching or exceeding marker	Probability of exactly reaching marker
B-C	0.02	0.00	0.00	0.02	0.02			N/A	N/A
B-A	0.20	0.00	0.00	0.20	0.20			N/A	N/A
C-AB	0.01	0.00	0.00	0.01	0.01			N/A	N/A

08:00 - 08:15

Stream	Mean (Veh)	Q05 (Veh)	Q50 (Veh)	Q90 (Veh)	Q95 (Veh)	Percentile message	Marker message	Probability of reaching or exceeding marker	Probability of exactly reaching marker
B-C	0.03	0.03	0.25	0.45	0.48			N/A	N/A
B-A	0.27	0.00	0.00	0.27	0.27			N/A	N/A
C-AB	0.02	0.02	0.25	0.45	0.48			N/A	N/A

08:15 - 08:30

Stream	Mean (Veh)	Q05 (Veh)	Q50 (Veh)	Q90 (Veh)	Q95 (Veh)	Percentile message	Marker message	Probability of reaching or exceeding marker	Probability of exactly reaching marker
B-C	0.04	0.03	0.25	0.45	0.48			N/A	N/A
B-A	0.41	0.03	0.26	0.47	0.49			N/A	N/A
C-AB	0.02	0.00	0.00	0.02	0.02			N/A	N/A

08:30 - 08:45

Stream	Mean (Veh)	Q05 (Veh)	Q50 (Veh)	Q90 (Veh)	Q95 (Veh)	Percentile message	Marker message	Probability of reaching or exceeding marker	Probability of exactly reaching marker
B-C	0.04	0.00	0.00	0.04	0.04			N/A	N/A
B-A	0.42	0.03	0.31	1.33	1.70			N/A	N/A
C-AB	0.02	0.00	0.00	0.02	0.02			N/A	N/A

08:45 - 09:00

Stream	Mean (Veh)	Q05 (Veh)	Q50 (Veh)	Q90 (Veh)	Q95 (Veh)	Percentile message	Marker message	Probability of reaching or exceeding marker	Probability of exactly reaching marker
B-C	0.03	0.00	0.00	0.03	0.03			N/A	N/A
B-A	0.28	0.00	0.00	0.28	0.28			N/A	N/A
C-AB	0.02	0.00	0.00	0.02	0.02			N/A	N/A

09:00 - 09:15

Stream	Mean (Veh)	Q05 (Veh)	Q50 (Veh)	Q90 (Veh)	Q95 (Veh)	Percentile message	Marker message	Probability of reaching or exceeding marker	Probability of exactly reaching marker
B-C	0.02	0.00	0.00	0.02	0.02			N/A	N/A
B-A	0.20	0.00	0.00	0.20	0.20			N/A	N/A
C-AB	0.01	0.00	0.00	0.01	0.01			N/A	N/A

2032 Do Something (FULL), PM

Data Errors and Warnings

Severity	Area	Item	Description
Warning	Queue variations	Analysis Options	Queue percentiles may be unreliable if the mean queue in any time segment is very low or very high.

Junction Network

Junctions

Junction	Name	Junction type	Major road direction	Use circulating lanes	Junction Delay (s)	Junction LOS
1	Mill Lane/Delph Lane	T-Junction	Two-way		1.02	A

Junction Network Options

Driving side	Lighting
Left	Normal/unknown

Traffic Demand

Demand Set Details

ID	Scenario name	Time Period name	Traffic profile type	Start time (HH:mm)	Finish time (HH:mm)	Time segment length (min)
D14	2032 Do Something (FULL)	PM	ONE HOUR	16:45	18:15	15

Vehicle mix source	PCU Factor for a HV (PCU)
HV Percentages	2.00

Demand overview (Traffic)

Arm	Linked arm	Use O-D data	Average Demand (Veh/hr)	Scaling Factor (%)
A		✓	596	100.000
B		✓	77	100.000
C		✓	556	100.000

Origin-Destination Data

Demand (Veh/hr)

		To		
		A	B	C
From	A	0	105	491
	B	65	0	12
	C	531	25	0

Vehicle Mix

Heavy Vehicle Percentages

		To		
		A	B	C
From	A	0	0	0
	B	0	0	8
	C	0	4	0

Results

Results Summary for whole modelled period

Stream	Max RFC	Max Delay (s)	Max Queue (Veh)	Max 95th percentile Queue (Veh)	Max LOS
B-C	0.02	6.80	0.0	0.5	A
B-A	0.22	14.60	0.3	1.3	B
C-AB	0.06	7.78	0.1	0.5	A
C-A					
A-B					
A-C					

Main Results for each time segment

16:45 - 17:00

Stream	Total Demand (Veh/hr)	Capacity (Veh/hr)	RFC	Throughput (Veh/hr)	End queue (Veh)	Delay (s)	Unsignalised level of service
B-C	9	606	0.015	9	0.0	6.031	A
B-A	49	395	0.124	48	0.1	10.376	B
C-AB	19	516	0.038	19	0.0	7.250	A
C-A	399			399			
A-B	79			79			
A-C	370			370			

17:00 - 17:15

Stream	Total Demand (Veh/hr)	Capacity (Veh/hr)	RFC	Throughput (Veh/hr)	End queue (Veh)	Delay (s)	Unsignalised level of service
B-C	11	580	0.019	11	0.0	6.326	A
B-A	58	363	0.161	58	0.2	11.821	B
C-AB	24	505	0.047	24	0.1	7.481	A
C-A	476			476			
A-B	94			94			
A-C	441			441			

17:15 - 17:30

Stream	Total Demand (Veh/hr)	Capacity (Veh/hr)	RFC	Throughput (Veh/hr)	End queue (Veh)	Delay (s)	Unsignalised level of service
B-C	13	543	0.024	13	0.0	6.796	A
B-A	72	318	0.225	71	0.3	14.532	B
C-AB	30	493	0.061	30	0.1	7.774	A
C-A	582			582			
A-B	116			116			
A-C	541			541			

17:30 - 17:45

Stream	Total Demand (Veh/hr)	Capacity (Veh/hr)	RFC	Throughput (Veh/hr)	End queue (Veh)	Delay (s)	Unsignalised level of service
B-C	13	543	0.024	13	0.0	6.798	A
B-A	72	318	0.225	72	0.3	14.601	B
C-AB	30	493	0.061	30	0.1	7.777	A
C-A	582			582			
A-B	116			116			
A-C	541			541			

17:45 - 18:00

Stream	Total Demand (Veh/hr)	Capacity (Veh/hr)	RFC	Throughput (Veh/hr)	End queue (Veh)	Delay (s)	Unsignalised level of service
B-C	11	580	0.019	11	0.0	6.331	A
B-A	58	363	0.161	59	0.2	11.865	B
C-AB	24	504	0.047	24	0.1	7.486	A
C-A	476			476			
A-B	94			94			
A-C	441			441			

18:00 - 18:15

Stream	Total Demand (Veh/hr)	Capacity (Veh/hr)	RFC	Throughput (Veh/hr)	End queue (Veh)	Delay (s)	Unsignalised level of service
B-C	9	606	0.015	9	0.0	6.034	A
B-A	49	395	0.124	49	0.1	10.425	B
C-AB	19	516	0.038	20	0.0	7.257	A
C-A	399			399			
A-B	79			79			
A-C	370			370			

Queue Variation Results for each time segment

16:45 - 17:00

Stream	Mean (Veh)	Q05 (Veh)	Q50 (Veh)	Q90 (Veh)	Q95 (Veh)	Percentile message	Marker message	Probability of reaching or exceeding marker	Probability of exactly reaching marker
B-C	0.02	0.00	0.00	0.02	0.02			N/A	N/A
B-A	0.14	0.00	0.00	0.14	0.14			N/A	N/A
C-AB	0.04	0.00	0.00	0.04	0.04			N/A	N/A

17:00 - 17:15

Stream	Mean (Veh)	Q05 (Veh)	Q50 (Veh)	Q90 (Veh)	Q95 (Veh)	Percentile message	Marker message	Probability of reaching or exceeding marker	Probability of exactly reaching marker
B-C	0.02	0.02	0.25	0.45	0.48			N/A	N/A
B-A	0.19	0.00	0.00	0.19	0.19			N/A	N/A
C-AB	0.05	0.03	0.25	0.45	0.48			N/A	N/A

17:15 - 17:30

Stream	Mean (Veh)	Q05 (Veh)	Q50 (Veh)	Q90 (Veh)	Q95 (Veh)	Percentile message	Marker message	Probability of reaching or exceeding marker	Probability of exactly reaching marker
B-C	0.02	0.00	0.00	0.02	0.02			N/A	N/A
B-A	0.28	0.03	0.26	0.47	0.49			N/A	N/A
C-AB	0.07	0.03	0.26	0.47	0.49			N/A	N/A

17:30 - 17:45

Stream	Mean (Veh)	Q05 (Veh)	Q50 (Veh)	Q90 (Veh)	Q95 (Veh)	Percentile message	Marker message	Probability of reaching or exceeding marker	Probability of exactly reaching marker
B-C	0.02	0.00	0.00	0.02	0.02			N/A	N/A
B-A	0.29	0.03	0.31	1.02	1.33			N/A	N/A
C-AB	0.07	0.00	0.00	0.07	0.07			N/A	N/A

17:45 - 18:00

Stream	Mean (Veh)	Q05 (Veh)	Q50 (Veh)	Q90 (Veh)	Q95 (Veh)	Percentile message	Marker message	Probability of reaching or exceeding marker	Probability of exactly reaching marker
B-C	0.02	0.00	0.00	0.02	0.02			N/A	N/A
B-A	0.20	0.00	0.00	0.20	0.20			N/A	N/A
C-AB	0.05	0.00	0.00	0.05	0.05			N/A	N/A

18:00 - 18:15

Stream	Mean (Veh)	Q05 (Veh)	Q50 (Veh)	Q90 (Veh)	Q95 (Veh)	Percentile message	Marker message	Probability of reaching or exceeding marker	Probability of exactly reaching marker
B-C	0.02	0.00	0.00	0.02	0.02			N/A	N/A
B-A	0.14	0.00	0.00	0.14	0.14			N/A	N/A
C-AB	0.04	0.00	0.00	0.04	0.04			N/A	N/A

2019 Calibration, AM

Data Errors and Warnings

Severity	Area	Item	Description
Warning	Queue variations	Analysis Options	Queue percentiles may be unreliable if the mean queue in any time segment is very low or very high.

Junction Network

Junctions

Junction	Name	Junction type	Major road direction	Use circulating lanes	Junction Delay (s)	Junction LOS
1	Mill Lane/Delph Lane	T-Junction	Two-way		0.31	A

Junction Network Options

Driving side	Lighting
Left	Normal/unknown

Traffic Demand

Demand Set Details

ID	Scenario name	Time Period name	Traffic profile type	Start time (HH:mm)	Finish time (HH:mm)	Time segment length (min)
D15	2019 Calibration	AM	ONE HOUR	07:45	09:15	15

Vehicle mix source	PCU Factor for a HV (PCU)
HV Percentages	2.00

Demand overview (Traffic)

Arm	Linked arm	Use O-D data	Average Demand (Veh/hr)	Scaling Factor (%)
A		✓	370	100.000
B		✓	28	100.000
C		✓	559	100.000

Origin-Destination Data

Demand (Veh/hr)

		To		
		A	B	C
From	A	0	9	361
	B	17	0	11
	C	555	4	0

Vehicle Mix

Heavy Vehicle Percentages

		To		
		A	B	C
From	A	0	0	1
	B	6	0	0
	C	2	25	0

Results

Results Summary for whole modelled period

Stream	Max RFC	Max Delay (s)	Max Queue (Veh)	Max 95th percentile Queue (Veh)	Max LOS
B-C	0.02	5.52	0.0	0.5	A
B-A	0.05	11.08	0.1	0.5	B
C-AB	0.01	8.32	0.0	0.5	A
C-A					
A-B					
A-C					

Main Results for each time segment

07:45 - 08:00

Stream	Total Demand (Veh/hr)	Capacity (Veh/hr)	RFC	Throughput (Veh/hr)	End queue (Veh)	Delay (s)	Unsignalised level of service
B-C	8	705	0.012	8	0.0	5.163	A
B-A	13	402	0.032	13	0.0	9.238	A
C-AB	3	453	0.007	3	0.0	8.002	A
C-A	418			418			
A-B	7			7			
A-C	272			272			

08:00 - 08:15

Stream	Total Demand (Veh/hr)	Capacity (Veh/hr)	RFC	Throughput (Veh/hr)	End queue (Veh)	Delay (s)	Unsignalised level of service
B-C	10	688	0.014	10	0.0	5.305	A
B-A	15	378	0.040	15	0.0	9.931	A
C-AB	4	446	0.008	4	0.0	8.137	A
C-A	499			499			
A-B	8			8			
A-C	325			325			

08:15 - 08:30

Stream	Total Demand (Veh/hr)	Capacity (Veh/hr)	RFC	Throughput (Veh/hr)	End queue (Veh)	Delay (s)	Unsignalised level of service
B-C	12	665	0.018	12	0.0	5.515	A
B-A	19	344	0.054	19	0.1	11.074	B
C-AB	5	438	0.010	5	0.0	8.314	A
C-A	611			611			
A-B	10			10			
A-C	397			397			

08:30 - 08:45

Stream	Total Demand (Veh/hr)	Capacity (Veh/hr)	RFC	Throughput (Veh/hr)	End queue (Veh)	Delay (s)	Unsignalised level of service
B-C	12	665	0.018	12	0.0	5.516	A
B-A	19	344	0.054	19	0.1	11.076	B
C-AB	5	438	0.010	5	0.0	8.316	A
C-A	611			611			
A-B	10			10			
A-C	397			397			

08:45 - 09:00

Stream	Total Demand (Veh/hr)	Capacity (Veh/hr)	RFC	Throughput (Veh/hr)	End queue (Veh)	Delay (s)	Unsignalised level of service
B-C	10	688	0.014	10	0.0	5.308	A
B-A	15	378	0.040	15	0.0	9.939	A
C-AB	4	446	0.008	4	0.0	8.139	A
C-A	499			499			
A-B	8			8			
A-C	325			325			

09:00 - 09:15

Stream	Total Demand (Veh/hr)	Capacity (Veh/hr)	RFC	Throughput (Veh/hr)	End queue (Veh)	Delay (s)	Unsignalised level of service
B-C	8	705	0.012	8	0.0	5.166	A
B-A	13	402	0.032	13	0.0	9.246	A
C-AB	3	453	0.007	3	0.0	8.003	A
C-A	418			418			
A-B	7			7			
A-C	272			272			

Queue Variation Results for each time segment**07:45 - 08:00**

Stream	Mean (Veh)	Q05 (Veh)	Q50 (Veh)	Q90 (Veh)	Q95 (Veh)	Percentile message	Marker message	Probability of reaching or exceeding marker	Probability of exactly reaching marker
B-C	0.01	0.00	0.00	0.01	0.01			N/A	N/A
B-A	0.03	0.00	0.00	0.03	0.03			N/A	N/A
C-AB	0.01	0.00	0.00	0.01	0.01			N/A	N/A

08:00 - 08:15

Stream	Mean (Veh)	Q05 (Veh)	Q50 (Veh)	Q90 (Veh)	Q95 (Veh)	Percentile message	Marker message	Probability of reaching or exceeding marker	Probability of exactly reaching marker
B-C	0.01	0.01	0.25	0.45	0.48			N/A	N/A
B-A	0.04	0.03	0.25	0.45	0.48			N/A	N/A
C-AB	0.01	0.01	0.25	0.45	0.48			N/A	N/A

08:15 - 08:30

Stream	Mean (Veh)	Q05 (Veh)	Q50 (Veh)	Q90 (Veh)	Q95 (Veh)	Percentile message	Marker message	Probability of reaching or exceeding marker	Probability of exactly reaching marker
B-C	0.02	0.00	0.00	0.02	0.02			N/A	N/A
B-A	0.06	0.03	0.26	0.46	0.49			N/A	N/A
C-AB	0.01	0.00	0.00	0.01	0.01			N/A	N/A

08:30 - 08:45

Stream	Mean (Veh)	Q05 (Veh)	Q50 (Veh)	Q90 (Veh)	Q95 (Veh)	Percentile message	Marker message	Probability of reaching or exceeding marker	Probability of exactly reaching marker
B-C	0.02	0.00	0.00	0.02	0.02			N/A	N/A
B-A	0.06	0.00	0.00	0.06	0.06			N/A	N/A
C-AB	0.01	0.00	0.00	0.01	0.01			N/A	N/A

08:45 - 09:00

Stream	Mean (Veh)	Q05 (Veh)	Q50 (Veh)	Q90 (Veh)	Q95 (Veh)	Percentile message	Marker message	Probability of reaching or exceeding marker	Probability of exactly reaching marker
B-C	0.01	0.00	0.00	0.01	0.01			N/A	N/A
B-A	0.04	0.00	0.00	0.04	0.04			N/A	N/A
C-AB	0.01	0.00	0.00	0.01	0.01			N/A	N/A

09:00 - 09:15

Stream	Mean (Veh)	Q05 (Veh)	Q50 (Veh)	Q90 (Veh)	Q95 (Veh)	Percentile message	Marker message	Probability of reaching or exceeding marker	Probability of exactly reaching marker
B-C	0.01	0.00	0.00	0.01	0.01			N/A	N/A
B-A	0.03	0.00	0.00	0.03	0.03			N/A	N/A
C-AB	0.01	0.00	0.00	0.01	0.01			N/A	N/A

2019 Calibration, PM

Data Errors and Warnings

Severity	Area	Item	Description
Warning	Queue variations	Analysis Options	Queue percentiles may be unreliable if the mean queue in any time segment is very low or very high.

Junction Network

Junctions

Junction	Name	Junction type	Major road direction	Use circulating lanes	Junction Delay (s)	Junction LOS
1	Mill Lane/Delph Lane	T-Junction	Two-way		0.49	A

Junction Network Options

Driving side	Lighting
Left	Normal/unknown

Traffic Demand

Demand Set Details

ID	Scenario name	Time Period name	Traffic profile type	Start time (HH:mm)	Finish time (HH:mm)	Time segment length (min)
D16	2019 Calibration	PM	ONE HOUR	16:45	18:15	15

Vehicle mix source	PCU Factor for a HV (PCU)
HV Percentages	2.00

Demand overview (Traffic)

Arm	Linked arm	Use O-D data	Average Demand (Veh/hr)	Scaling Factor (%)
A		✓	491	100.000
B		✓	31	100.000
C		✓	405	100.000

Origin-Destination Data

Demand (Veh/hr)

		To		
		A	B	C
From	A	0	38	453
	B	24	0	7
	C	387	18	0

Vehicle Mix

Heavy Vehicle Percentages

		To		
		A	B	C
From	A	0	0	0
	B	0	0	14
	C	1	6	0

Results

Results Summary for whole modelled period

Stream	Max RFC	Max Delay (s)	Max Queue (Veh)	Max 95th percentile Queue (Veh)	Max LOS
B-C	0.01	6.60	0.0	0.5	A
B-A	0.07	10.74	0.1	0.5	B
C-AB	0.04	7.66	0.0	0.5	A
C-A					
A-B					
A-C					

Main Results for each time segment

16:45 - 17:00

Stream	Total Demand (Veh/hr)	Capacity (Veh/hr)	RFC	Throughput (Veh/hr)	End queue (Veh)	Delay (s)	Unsignalised level of service
B-C	5	598	0.009	5	0.0	6.070	A
B-A	18	425	0.043	18	0.0	8.848	A
C-AB	14	516	0.027	14	0.0	7.169	A
C-A	291			291			
A-B	29			29			
A-C	341			341			

17:00 - 17:15

Stream	Total Demand (Veh/hr)	Capacity (Veh/hr)	RFC	Throughput (Veh/hr)	End queue (Veh)	Delay (s)	Unsignalised level of service
B-C	6	579	0.011	6	0.0	6.282	A
B-A	22	398	0.054	22	0.1	9.557	A
C-AB	17	505	0.033	17	0.0	7.375	A
C-A	347			347			
A-B	34			34			
A-C	407			407			

17:15 - 17:30

Stream	Total Demand (Veh/hr)	Capacity (Veh/hr)	RFC	Throughput (Veh/hr)	End queue (Veh)	Delay (s)	Unsignalised level of service
B-C	8	553	0.014	8	0.0	6.602	A
B-A	26	362	0.073	26	0.1	10.732	B
C-AB	21	491	0.042	21	0.0	7.653	A
C-A	425			425			
A-B	42			42			
A-C	499			499			

17:30 - 17:45

Stream	Total Demand (Veh/hr)	Capacity (Veh/hr)	RFC	Throughput (Veh/hr)	End queue (Veh)	Delay (s)	Unsignalised level of service
B-C	8	553	0.014	8	0.0	6.602	A
B-A	26	362	0.073	26	0.1	10.737	B
C-AB	21	491	0.042	21	0.0	7.656	A
C-A	425			425			
A-B	42			42			
A-C	499			499			

17:45 - 18:00

Stream	Total Demand (Veh/hr)	Capacity (Veh/hr)	RFC	Throughput (Veh/hr)	End queue (Veh)	Delay (s)	Unsignalised level of service
B-C	6	579	0.011	6	0.0	6.285	A
B-A	22	398	0.054	22	0.1	9.565	A
C-AB	17	504	0.033	17	0.0	7.376	A
C-A	347			347			
A-B	34			34			
A-C	407			407			

18:00 - 18:15

Stream	Total Demand (Veh/hr)	Capacity (Veh/hr)	RFC	Throughput (Veh/hr)	End queue (Veh)	Delay (s)	Unsignalised level of service
B-C	5	598	0.009	5	0.0	6.071	A
B-A	18	425	0.043	18	0.0	8.859	A
C-AB	14	516	0.027	14	0.0	7.175	A
C-A	291			291			
A-B	29			29			
A-C	341			341			

Queue Variation Results for each time segment

16:45 - 17:00

Stream	Mean (Veh)	Q05 (Veh)	Q50 (Veh)	Q90 (Veh)	Q95 (Veh)	Percentile message	Marker message	Probability of reaching or exceeding marker	Probability of exactly reaching marker
B-C	0.01	0.00	0.00	0.01	0.01			N/A	N/A
B-A	0.04	0.00	0.00	0.04	0.04			N/A	N/A
C-AB	0.03	0.00	0.00	0.03	0.03			N/A	N/A

17:00 - 17:15

Stream	Mean (Veh)	Q05 (Veh)	Q50 (Veh)	Q90 (Veh)	Q95 (Veh)	Percentile message	Marker message	Probability of reaching or exceeding marker	Probability of exactly reaching marker
B-C	0.01	0.01	0.25	0.45	0.48			N/A	N/A
B-A	0.06	0.03	0.25	0.45	0.48			N/A	N/A
C-AB	0.03	0.03	0.25	0.45	0.48			N/A	N/A

17:15 - 17:30

Stream	Mean (Veh)	Q05 (Veh)	Q50 (Veh)	Q90 (Veh)	Q95 (Veh)	Percentile message	Marker message	Probability of reaching or exceeding marker	Probability of exactly reaching marker
B-C	0.01	0.00	0.00	0.01	0.01			N/A	N/A
B-A	0.08	0.03	0.26	0.47	0.49			N/A	N/A
C-AB	0.05	0.03	0.25	0.46	0.48			N/A	N/A

17:30 - 17:45

Stream	Mean (Veh)	Q05 (Veh)	Q50 (Veh)	Q90 (Veh)	Q95 (Veh)	Percentile message	Marker message	Probability of reaching or exceeding marker	Probability of exactly reaching marker
B-C	0.01	0.00	0.00	0.01	0.01			N/A	N/A
B-A	0.08	0.03	0.25	0.45	0.48			N/A	N/A
C-AB	0.05	0.00	0.00	0.05	0.05			N/A	N/A

17:45 - 18:00

Stream	Mean (Veh)	Q05 (Veh)	Q50 (Veh)	Q90 (Veh)	Q95 (Veh)	Percentile message	Marker message	Probability of reaching or exceeding marker	Probability of exactly reaching marker
B-C	0.01	0.00	0.00	0.01	0.01			N/A	N/A
B-A	0.06	0.00	0.00	0.06	0.06			N/A	N/A
C-AB	0.04	0.00	0.00	0.04	0.04			N/A	N/A

18:00 - 18:15

Stream	Mean (Veh)	Q05 (Veh)	Q50 (Veh)	Q90 (Veh)	Q95 (Veh)	Percentile message	Marker message	Probability of reaching or exceeding marker	Probability of exactly reaching marker
B-C	0.01	0.00	0.00	0.01	0.01			N/A	N/A
B-A	0.04	0.00	0.00	0.04	0.04			N/A	N/A
C-AB	0.03	0.00	0.00	0.03	0.03			N/A	N/A